

harmony index

natuzzi
italia
collection
2022-2023

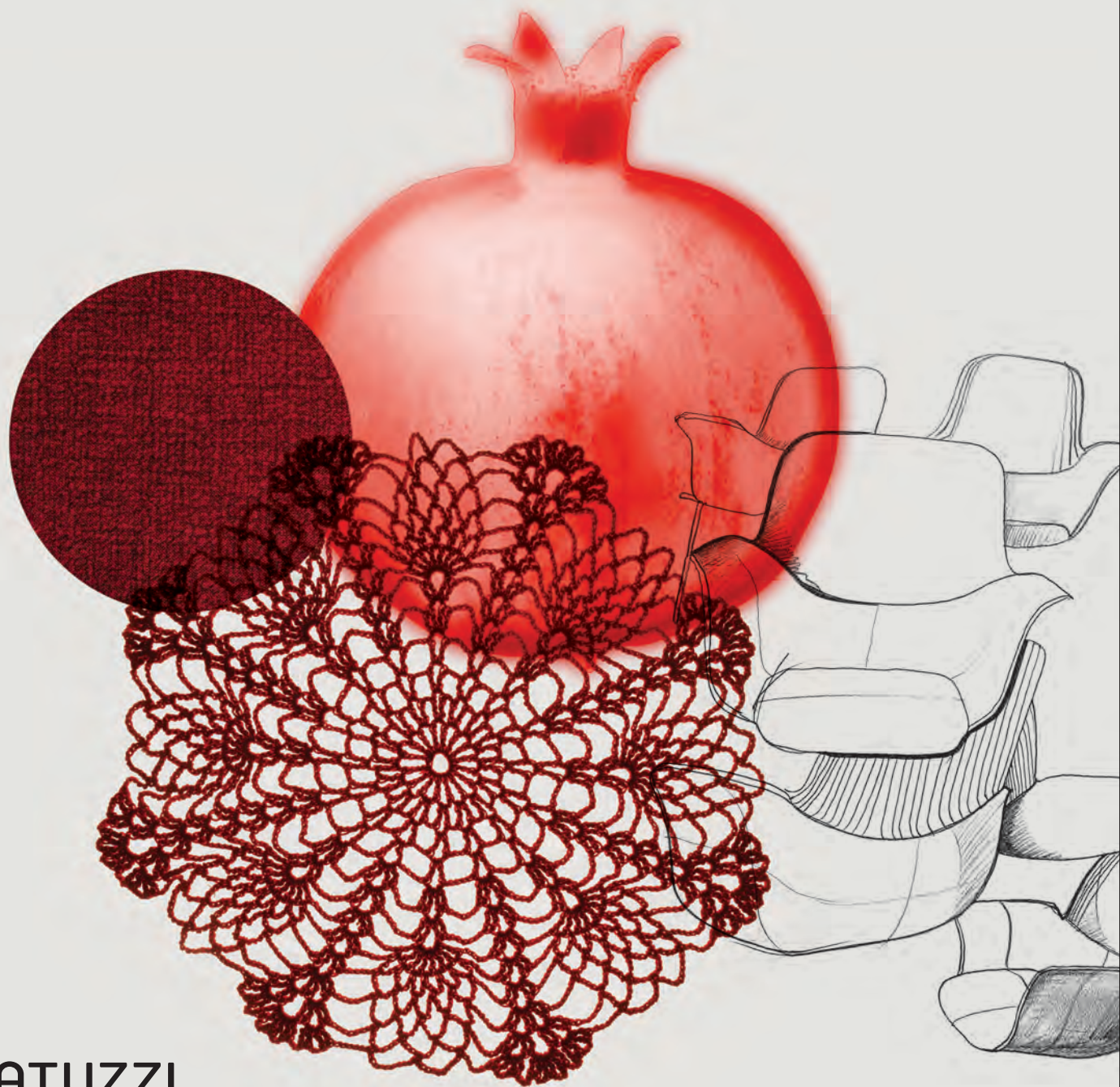

NATUZZI
ITALIA



Our roots lie deep in a land where beauty has been created and harvested for thousands of years, day upon day, season after season, as if it were a fruit. And today we offer that very same beauty to the whole world. And that fruit is harmony, with its unique flavour, capturing the Mediterranean, its civilisation and its way of life - one that is unsurpassed to this day.

Paolo Polizzi

N



Tony Chambers is a Creative Director, Design Consultant and Editor. He is the founder of multidisciplinary creative agency TC & Friends and Co-Chair of Brainstorm Design, Fortune magazine's design & business conference. Tony is the editor and creative director of the definitive monograph of designer Paul Smith, published by Phaidon. He sits on the board of the Barbican Art Centre and the Whitechapel Galleries Ventures board. From 2003 to 2018 Tony served as Editor-in-Chief and Creative Director of Wallpaper* magazine, for which he still contributes. He also served as Art Director of British GQ and Art Editor of The Sunday Times Magazine. He has twice been named the PPA Designer of Year and twice Editor of the Year by the BSME. In 2015 he was the recipient of the Mark Boxer Award for outstanding services to the Publishing Industry – the most prestigious honour in British publishing.

It's a great pleasure to introduce the 2021 Natuzzi catalogue. During my many years at the helm of Wallpaper* magazine, the transformation in the positioning of Natuzzi as a brand stands out as one of the most interesting and brightest moments.

Natuzzi is a brand that oozes style, passion and authenticity. A design brand that is unique in its outlook and unique in its output and this is due to one main reason – the passion and dedication of the owners – the Natuzzi family.

All great brands are sustained in some way by their history. By their story. And what a great story there is behind Natuzzi. I know it well because it was told to me a few years ago by Chief creative officer Pasquale Junior and one image has stayed with me since. That of his father, the Founder and CEO, setting off from Apulia on a journey of discovery across America in the early 80s at a time when he spoke very little, if any, English. Driven by a mix of ambition, curiosity and bravery, Pasquale worked his way through the many huge furniture fairs, trade shows and show rooms and was struck by a distinct lack of variety, colour and flair. He was convinced that the World would love what Natuzzi could offer.

Fast forward to today and it is clear that Pasquale Junior has inherited that same passion, curiosity and drive. In the short time I have known him he has transformed this hugely successful furniture maker into the hugely successful directional lifestyle brand we see presented so exquisitely across the pages of this catalogue.

It is a collection that speaks of harmony and a blend of design influences. It is international in flavour but still very much rooted in the culture and values of Apulia. Produced by designers with very different approaches and experiences – it is indeed a special blend.

It is all about the harmonious blending of tradition with modernity. The blending of craftsmanship with innovation, of form with function, sustainability with glamour, and comfort with style. This entire collection highlights Natuzzi's great propensity for innovation, which is a key cornerstone of the brand, while remaining faithful to tradition and to its own roots. It demonstrates and displays the vast know-how of Natuzzi craftsmen and their ability to develop complex and varied projects with great skill and sophistication.

For me, it also exemplifies a blending of Natuzzi's rich past, present and future. And on this evidence, the future looks really exciting.

Tony Chambers

index

- 6 **natuzzi knows how**
- 12 **natuzzi and its designers.
evolving harmony.**
- 14 **natuzzi from a to z**
- 16 **living**
harmony comes from change.
 - 512 re-vive
- 524 **dining**
the harmony of new
everyday habits.
- 594 **bedroom**
harmony, a dream
that comes true.
 - 676 sleeping
in natural harmony
 - 678 a soft, warm, silky
embrace
- 680 **the place of harmony**
- 682 **soul and matter**
- 691 **technical specifications**
 - 692 sofas
 - 754 sofa beds
 - 756 re-vive
 - 760 armchairs
 - 781 ottomans and benches
 - 786 chairs
 - 793 beds
 - 799 coffee tables
 - 813 tables
 - 820 desks
 - 824 bookcases
 - 826 bar cabinet
 - 827 sideboards
 - 831 bedroom furnishings
 - 836 rugs
 - 842 lamps
 - 848 mirrors
 - 851 blankets and cushions
 - 853 accessories
 - 857 room fragrances

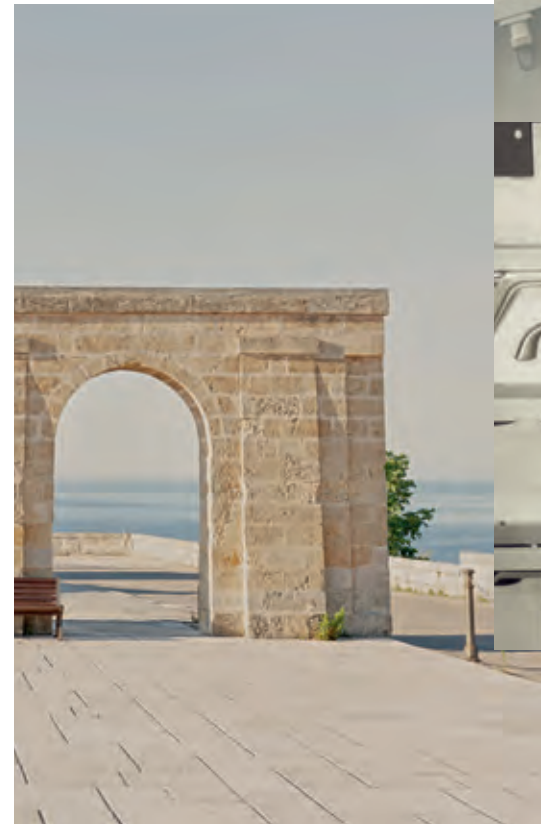
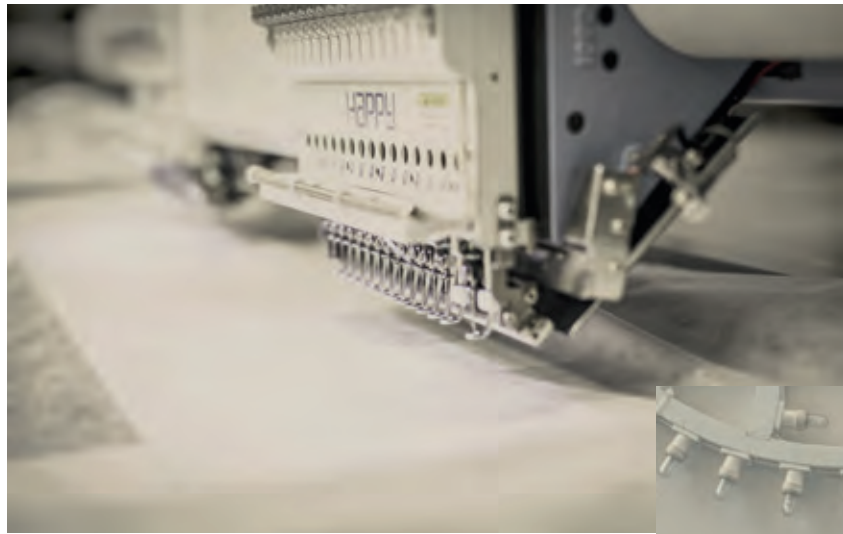

natuzzi knows how

Creating value for everyone while respecting everyone.

A foray into the ethics of harmony.

The pursuit of harmony – in design and life in general – is the dream that has shaped our actions since as far back as 1959. Harmony in the sense of the right balance between body and mind, mankind and nature, and between different peoples and culture; a means to enrich and complete one another, just as has been happening for thousands of years not only in our “Mother Land” – Apulia – but also all over the Mediterranean where a perpetual intermingling has generated boundless beauty and a lifestyle that continues to be an inspiration for many. One that is unrivalled still today in many different ways. With all of this in mind and without betraying its own DNA, Natuzzi Italia decided to carry over this sense of harmony into the world of interior décor, bridging the gap between a contemporary aesthetic and functionality, materials and colours, and between textures and graphic designs in a quest to create spaces and dwellings which emanate balance, elegance and beauty from every pore. Harmoniousness which is underpinned by aesthetic research and anchored by unassailable deeply rooted values –

ethics, transparency and sustainability. And in order to ensure that these values are respected and that quality standards exceed customer expectations, Natuzzi Italia has chosen to control the whole production chain, right the way down to actual delivery. A hub of international excellence and experience, the Natuzzi Style Center lies at the heart of everything. Every day designers, décor experts and colourists study and analyse what is happening in the aesthetic world (a combination of art, fashion and design) and how it is evolving – new forms, trends, colours, nuances, finishes and textures. All of this information is then used to create environments in which each single piece (from the sofa to the furnishing accessories, right down to decorative objects) mingle and coalesce into a cohesive space which exudes harmony. At this stage, the concept goes to the prototype centre where Natuzzi Italia's immense know-how comes to the fore. Because although it is the designer with his pencil on a sheet of blank paper who first sketches out an idea (and this is the stage of pure creativity),



it is the know-how of the best craftsmen in the world who, each time with almost alchemical precision, bring magic into play and turn the drawing into a tangible product.

As with a consummate tailor, very few tools are required: a tape measure, some scissors and the raw materials – wood, the filling and the covering. Everything else comes down to precious experience and talent, demonstrating once and for all that Italian design is (and always will be) in a league of its own. Working in concert with them but taking it from a different angle (the angle of innovation), the research and development team does its own part, studying new hi-tech materials, foams and innovative fibres as well as automated ergonomic mechanisms which raise the bar in terms of customer well-being and enjoyment. By investing in research and development, Natuzzi has stayed ahead of the style curve, flushed its leather with the colour (actually the colours) of our homeland and honed its work processes, such as laser cutting, in order to achieve pinpoint accuracy.



But, most of all, it has grown the concept of comfort which has always been the basis of Natuzzi's style. It has combined fine Italian craftsmanship and the most advanced technology in the lounging sector to accomplish its goals (ample proof of this is provided by Re-vive, the first armchair in the world that automatically adapts to the way you sit). Being able to rely on one of the most advanced quality-testing laboratories in the world, Natuzzi is also able to certify all these innovative features. Because it is not only sofas and armchairs that are made on Natuzzi's premises in Italy, it is their accompanying certificates as well.

And, at this point, our acknowledgement of Italy's particular vocation for beauty and quality merges with our immense gratitude for a place – Apulia – to which we owe everything.



Our determination to stay here and to keep on producing, innovating, investing and creating value here is the natural consequence of a business ethic which has guided our progress unerringly over the past 60 years. It is an integral part of a value chain that is the only way forward on the path to continued excellence. We tread this path every day and you accompany us along the way each time you choose one of our products. It is not only an aesthetic choice; it is a taking of sides – and we lie on the side of the Ethic of Harmony.

Which means loving and respecting nature, starting with the raw materials that our artisans lovingly handle day by day.



There is the wood and the forests that it is harvested from – and our commitment is FSC-certified®. Then there is the leather which we process using some of the most advanced solutions in Europe in order to protect the environment. And the air which we preserve by only using the limitless solar energy of Apulia to create our products. All our raw materials are tracked too because we expect our suppliers to provide the same quality guarantees and respect for the environment that we do. Not to mention respect for people. But our history and our forefathers taught us about another kind of sustainability. The great artisans of the past created objects that would last; they had a really long lifespan and gave years of use. Dusting off this philosophy and marrying it with timeless designs means delivering products that will be welcomed and treasured by the next generations as well. This is what we do. Because designing and producing objects that will last and last, for us, is a way to express our DNA. We are not just talking about materials; we are talking about style.

About ageless beauty and elegance that endure the passage of time and passing trends.

The beauty of an inimitably glorious home to which we were born and in which we were brought up; a home that delights the eye wherever you happen to cast it - Italy.

natuzzi and its designers. evolving harmony.

Natuzzi Italia's partnerships with designers from across the world take inspiration from the brand's values, seeking to showcase and share them in turn at all times. The most important of these values is Harmony. And the "place" in which the brand and its designers meet to define the style, content and goals of each new collection is the **Circle of Harmony**, modern incarnation of a time-honoured tradition still going strong in the Mediterranean culture - that of the symposium, the sharing and discussion of a topic of common interest in an informal, convivial setting.

Today the subject matter is change, the one we are experiencing and which we believe will allow us to fully enjoy a 'new normal', consolidating new equilibriums in a continually evolving context. We decided to bring together designers with very different experiences and backgrounds to discuss this topic and lay the foundations for a collection that encourages people to embrace this global transition in an active and engaged way.

Live the Transition, the concept behind the collection, is first and foremost a maxim addressed to the designers - and by designers to the world. A new way of understanding this new normal, supported by a vision rooted in the brand's DNA. The ability to embrace change and turn it into a moment of evolution is an instinct that has a strong presence in Mediterranean culture, which has always been open and dynamic, constantly evolving. This inspired the designers to deeply rethink our relationships with our home, focusing on our new living requirements and showcasing them through the innovative design vision of Natuzzi Italia. The result is a collection whose keywords are functionality, sustainability and wellbeing. The start of a *new Era of Harmony*.

Bernhardt & Vella,	348, 646, 651, 652
Borre Akkersdijk,	151
Claudio Bellini,	170, 216, 221, 223, 426, 550, 618, 624, 629, 630
Enrique Marti,	322
Fabio Novembre,	340,345
Formafantasma,	34, 41, 43
Formway Studio,	512
Lorenza Bozzoli,	88, 95
Manzoni&Tapinassi,	116, 121, 122, 125, 132, 136, 143, 144, 228, 236, 240, 288, 297, 335, 336, 347, 363, 388, 400, 404, 430, 436, 452, 484, 574, 577, 578, 622, 632, 637, 638, 640, 645, 660, 664
Marcantonio,	28, 33, 282
Marcel Wanders studio,	18, 23, 138, 200, 205, 206, 209, 210, 214, 215, 266, 526
Marco Piva,	530, 535
Massimiliano Raggi,	320, 645
Massimo Iosa Ghini,	62, 67, 536
Maurizio Manzoni,	162, 262, 268, 273, 308
Mauro Lipparini,	78, 93, 148, 152, 155, 160, 172, 184, 190, 195, 274, 293, 298, 307, 399, 408, 414, 423, 486, 505, 520, 521, 566, 572, 588, 593, 596, 600, 601
Michele Menescardi,	364, 470, 492
Nika Zupanc,	242, 245, 246, 249, 250, 254, 258, 261, 556, 561, 562
Paola Navone,	339, 366, 371
Patrick Norguet,	40, 608, 617
Sabine Marcelis	44, 49, 51

natuzzi

from a to z

seating

sofas

adam 18, 21, 25, 693
amalia 43, 694
apulo 34, 37, 38, 41, 695
argo 366, 370, 696
balance 416, 419, 697
block 44, 47, 698
bolder 52, 55, 699
borghese 397, 394, 700
botanic 350, 352, 701
brio 460,462, 702
buddie 148, 149, 156, 160, 703
calilla 68, 70, 704
campus 190, 192, 196, 566, 568, 705
cava 274, 276, 706
colosseo 298, 303, 707
deep 242, 243, 256, 708
diesis 454, 457, 458, 709
dominio 162, 164, 710
don giovanni 376, 379, 711
dorian 236, 239, 712
duca 413, 713
estro 264, 282, 385, 714
euforia 58, 60, 715
fidelio 228, 229, 239, 233, 716
fly 390, 717
galaxy 438, 440, 442, 584, 718
herman 55, 132, 135, 140, 146, 233, 719
iago 102, 104, 106, 110, 720
icon 470, 472, 721
infinito 284, 282, 722
jeremy 404, 407, 723
juno 62, 64, 67, 724
kendo 116, 199, 126, 128, 725
king 330, 333, 726
la scala 180, 183, 727
leaf 262, 264, 728
leuca 466, 729
levante 486, 488, 730
long beach 171, 176, 731
melpot 184, 187, 648, 732
new classic 340, 343, 345, 733
oblò 308, 313, 734

opus 432, 735
pablo 219, 224, 736
philo 356, 359, 360, 737
plaza 424, 425, 738
positano 268, 271, 739
preludio 496, 740
seagull 476, 479, 741
selva 316, 742
skyline 200, 203, 212, 743
sohay 78,81, 744
sophy 82, 85, 745
stan 322, 325, 327, 746
tempo 288, 290, 747
timeless 88, 90, 95, 748
tratto 400, 403, 749
valzer 96, 99, 750
volo 444, 446, 751
wave 252, 752

sofa beds

capriccio 506, 754
notturno 500, 503, 755

re-vive

re-vive casual 518, 756
re-vive lounge 519, 757
re-vive club 519, 756
re-vive myway 520, 757
re-vive quilted 518, 758
re-vive wing back 520, 759
re-vive shuttle 521, 758
re-vive 610 521, 759

armchairs

adore 243, 246, 558, 760
aftereight 760
amalia 348, 761
antepima 85, 87, 496, 498, 761
argo 369, 370, 762
aura 479, 483, 762
blossom 128, 131, 303, 763
botanic 352, 354, 764
butterfly 661, 663, 764
cammeo 765
campus 765
cassia 399, 766
clemmie 271, 273, 766

conca 146, 221, 767
couture 95, 144, 767
deep 256, 768
dodi 55, 385, 387, 768
dolly 379, 381, 769
dove 209, 214, 229, 769
ensis 70, 73, 770
fiorita 21, 27, 771
ilia 772
itria 316, 319, 773
jeremy 404, 407, 773
lave 203, 205, 677, 774
logos 359, 363, 457, 774
luna 432, 435, 775
margaret 149, 155, 775
marlene 183, 339, 776
penelope 104, 108, 776
platea 393, 466, 777
sleeping argo 369, 370, 777
talía 446, 448, 778
tratto 400, 403, 778
viaggio 119, 125, 135, 176, 779
wave 252, 256, 779

ottoman + benches

bis 385, 503, 781
herman 176, 239, 240, 432, 781
melpot 184, 187, 648, 782
scacco 604, 607, 783
skyline 110, 203, 783
terra 28, 31, 784
wave 254, 785

chairs

ambra 574, 580, 786
beat 539, 541, 792
dove 209, 214, 229, 786
edgar 528, 542, 548, 786
frida 187, 591, 593, 787
hedi 294, 787
mama 787
nanà 532, 612, 788
pi greco 419, 484, 789
rose 452, 789
shield 214, 789
sigma 789

sovrana 441, 584, 587, 790
tennis 790
valle 196, 568, 571, 791
vesta 552, 791
voyage 243, 252, 558, 561, 792

bed

beds

briq 618, 620, 793
cala 624, 627, 794
campus 596, 794
diamante 632, 635, 795
dolcevita 643, 795
ema 608, 610, 796
fenice 646, 648, 796
pincha 602, 604, 797
piuma 654, 797
svevo 660, 798
venere 632, 634, 798

mattresses and pillows

mattresses 676
pillows 676

furnishings

coffee and side tables

adam 21, 23, 799
cabaret 390, 403, 407, 488, 491, 491, 496, 799
campus 192, 195, 196, 599, 600, 800
cava 85, 276, 280, 352, 419, 423, 423, 479, 801
chocolat 98, 99, 369, 373, 801
estro 264, 382, 385, 802
feudo 37, 81, 90, 93, 802
fil rouge 303, 413, 414, 803

frost 70, 219, 223, 224, 804
herman 55, 64, 135, 136, 140, 146, 171, 176, 233, 239, 432, 436, 805
icon 359, 364, 457, 472, 806
ido 104, 807
ika 149, 152, 157, 808
kendo 119, 121, 128, 808
labirinto 385, 425, 426, 610, 809
mercurio 466, 468, 809
orfeo 333, 335, 343, 810
patio 47, 49, 810
saturday 446, 451, 811
skyline 60, 61, 110, 203, 212, 811
tempo 164, 290, 297, 812
voyage 243, 250, 812

tables

adam 526, 528, 813
aliante 530, 532, 814
campus 196, 566, 568, 570, 571, 815
gutta 536, 539, 816
kendo 574, 816
libra 542, 545, 817
new saturno 441, 582, 584, 817
ombra 550, 552, 818
phantom 187, 588, 591, 818
virgola 546, 548, 819
voyage 243, 252, 556, 558, 564, 819

shelving & storage

desks

fil rouge 503, 505, 820
inu 820
ika 160, 821
omega 452, 822
phantom 293, 823

bookcases

arch 67, 203, 215, 824
fil rouge 369, 413, 824
tide 256, 258, 825

bar cabinet

skyline 214, 826

sideboards

campus 568, 571, 572, 827
fil rouge 233, 828
fortuna 224, 441, 552, 555, 584, 828
ido 829
kendo 577, 829
orfeo 313, 317, 333, 347, 830
phantom 472, 830

bedroom furnishings

cala 627, 629, 630, 831
campus 600, 601, 797, 831, 832
euclide 635, 637, 638, 833
fenice 651, 652, 833
mondrian 654, 657, 658, 834
munari 642, 645, 834
svevo 620, 622, 661, 835
venere 666, 671, 836

decor

rugs

affresco 175, 180, 183, 298, 379, 472, 837
calcada 369, 374, 837
globes 104, 108, 342, 838
gorgonia 70, 72, 838
jade 441, 839
luce 55, 157, 159, 303, 839
magna grecia 64, 135, 138, 840
new decò 164, 168,

233, 840
papel 21, 836
seti 119, 176, 192, 271, 290, 313, 316, 841
silence 425, 429, 457, 841
sophia B 81, 90, 99, 110, 128, 140, 146, 187, 196, 203, 212, 219, 224, 229, 239, 276, 343, 352, 390, 403, 407, 413, 488, 552, 568, 610, 620, 627, 648, 654, 666, 842
vortex 243, 249, 249, 252, 558, 643, 661, 842

lamps

circle 441, 539, 584, 643, 645, 843
colosseo 80, 81, 172, 176, 183, 187, 192, 271, 284, 298, 307, 369, 407, 408, 472, 568, 643, 843
dami 104, 110, 212, 215, 215, 229, 239, 552, 571, 844
ding dong 264, 266, 419, 844
elsa 390, 496, 845
galileo 403, 488, 492, 492, 503, 627, 635, 648, 845
halo 316, 320, 333, 846
joy 243, 256, 261, 261, 252, 558, 562, 562, 846
kendo 119, 122, 180, 343, 578, 847
vico 196, 224, 359, 466, 620, 654, 661, 666, 847

mirrors

anemonia 74, 848
chocolat 187, 591, 593, 848
clouds 672, 849
kendo 290, 316, 664, 849
luminarie 210, 849
mermaid 256, 261, 558, 849
orfeo 180, 336, 850
sailor 256, 261, 850
tailor 88, 627, 666, 675, 850

plaid and cushions

dysidea 37, 70, 85, 99, 101, 851
kashmir 851
trulli 303, 403, 627, 852

accessories

ciabotte 70, 853
dandy 119, 212, 407, 853
pumo 64, 99, 110, 114, 128, 146, 164, 196, 199, 199, 219, 233, 239, 243, 264, 271, 290, 313, 316, 325, 333, 343, 352, 369, 397, 425, 441, 462, 479, 488, 558, 568, 584, 643, 854, 855
silo 135, 303, 369, 462, 855
urchin 85, 149, 203, 276, 333, 472, 548, 856
voyage magazine holder 252, 254, 256, 856

room fragrances

trullini 37, 60, 90, 264, 369, 446, 627, 857



living

harmony
comes
from change.

The ability to adapt to change is not only a virtue requested of people: our furnishings are also required to become more "versatile", capable of meeting different needs, reinventing themselves continuously. This is particularly true of the sofa, icon of the Natuzzi style. Today more than ever, everything revolves around this item of furniture - social occasions, conversation, reading, music, relaxation, work and study. While the interior spaces of our homes adapt to our new day-to-day lives, the sofa becomes the embodiment of our new living priorities, functionality and continuity between spaces, which it interprets with a style that never fails to amaze. Centrepiece of an interior design story enriched on a daily basis with new characters - side tables, armchairs, bookcases, desks, sideboards, bar furniture - that share the same mission: to live (and allow you to live) in harmony.

designed by
Marcel Wanders studio

adam

Like the first inhabitant of that ancestral pristine Earth, Adam is the name of the sofa that Natuzzi has created in collaboration with the Marcel Wanders studio. A new interpretation of the iconic Natuzzi style, enhanced to make it an archetype for its subsequent evolutions, Adam is designed with the desire to combine natural materials and a timeless look inspired by Puglia, the region that represents the brand's roots and symbolizes the Mediterranean lifestyle that it brings to the world.





Adam sectional sofa shown
in siena leather
H76 – W390 – D224cm
H30 – W154 – D88”
Fiiorita armchair.
Adam coffe table.
Papel rug.

An integrated ottoman version
is available that can also be
used with a dual function, as
additional seating or as a shelf
to serve the sofa.



Multi-position adjustable armrest with snap mechanism when opened and friction when closed. The function of armrest and headrest, and the wide and generous seats, invite you to enjoy maximum comfort.

adam coffee table

designed by
Marcel Wanders studio



Adam includes an integrated offer of complementary furniture. The collection of Small Tables and Accents is available in various sizes and different heights to meet the various functions of living. Small tables that can live alone but become protagonists of the scene when they match with each other thanks to the mix of different materials available.

For this collection we use FSC-certified wood and a new brushed Lecce stone finish, an innovative stone effect texture, which is made from natural and recycled raw materials.

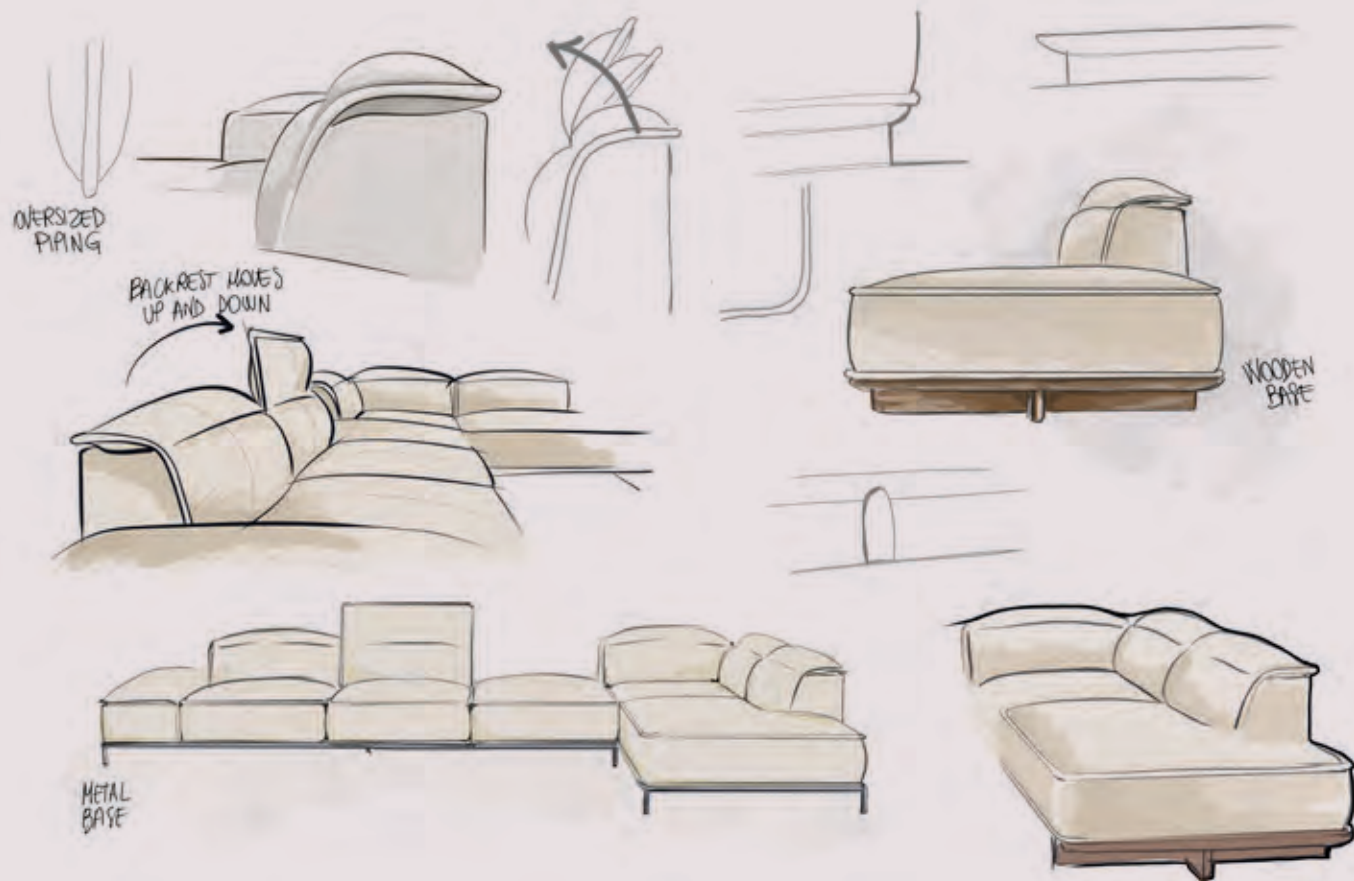

“Nature, origins, earth: this collection not only reflects Puglia’s ancestral style and rich artisanal history, but is capable of living a second life by being timeless.”

— Marcel Wanders



Adam, thanks to its extreme versatility of configurations and upholstery, satisfies every need for space and comfort. Upholstered sofa sides with hidden, removable hooks. The solid wood or metal base and piping along the entire profile of the sofa enrich and emphasize the design of the model.

Microcellular polyurethane foam padding made from a plant based raw material, drawing from renewable sources found in nature.





fiorita

designed by
Natuzzi Design Center



Fiorita is a power recliner chair. Thanks to invisible controls built into its structure, you can move its sophisticated Dual power mechanisms until you find the best position for your total comfort. An intimate and relaxed moment to take a break from everyday life. It embraces and supports you with a well-padded backrest. The solid steel swivel base allows **Fiorita** to rotate at your will.

designed by
Marcantonio

terra

“Nomen omen”, the Latins said. In the name, its destiny. Terra means Earth and right from its name we wanted to emphasise the close bond that binds it to it. Terra was created to rest directly on the ground, without any other filter or structural barrier. And it has been produced from the earth and for the earth, being composed only of biobased materials and eco-friendly coatings, with the utmost respect for the planet.





Terra pouf shown in Gaia eco-fabric and siena leather.
L60 – P98 – H90 cm
L24 – P39 – H35"

Terra is produced in Natuzzi Italia factories equipped with more than two thousand photovoltaic panels and a fluid-free heating system and is designed to be a totally eco-friendly product. It has an iconic design that can be used in different environments of the house.

Padding in recycled polystyrene that make it light and adaptable in shape to achieve the desired comfort.

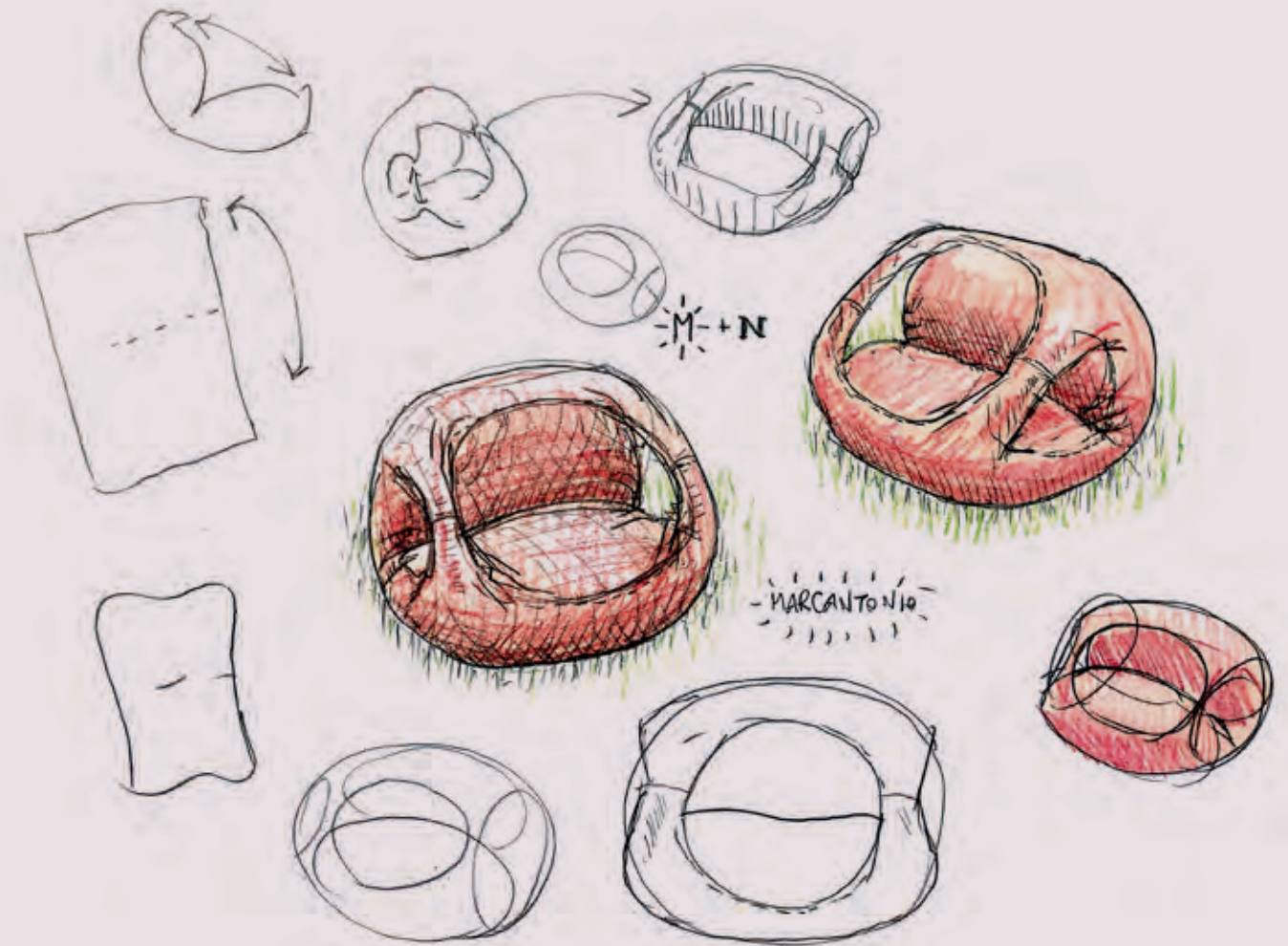

“Natuzzi made me experience the heritage of his land, Puglia, from whose simplicity and naturalness this project was born. Terra with its armrests recalls a hug to our planet and to the right causes to defend it.”

— Marcantonio

designed by
Formafantasma

apulo

Apulo embodies a new concept of versatility, created to merge multifunctionality, comfort and design and inspired by the rational realism of rural Puglia. To which it pays tribute, starting with the name. The barrel vaults of the old farmhouses are revived in its curves, as are traditional objects created for work, such as the rake, reproduced in the sofa.





Apulo sectional sofa
shown in Stylish leather.
H71 - W268 - D239 cm
H28 - W106 - D94"
Feudo coffee table.
Trullini air scents.
Dysidea cushions.

A wooden desk to be attached to the back of the frame provides a comfortable work surface. **Apulo** expands its functions according to the increasingly sophisticated requirements of the home

A duct to conceal electric cables belonging to a laptop is integrated into the structure of the sofa. In one detail, Natuzzi Italia's continuing design research





apulo

designed by
Formafantasma

A height-adjustable side table increases the functionality, providing an additional supporting surface.

Apulo side table in natural Ash wood.





Founded in Amsterdam by Andrea Trimarchi and Simone Farresin, **Formafantasma** is a design firm whose research is based on investigating the historical, political, ecological and social forces that influence today's design culture. This gives them a unique perspective on the legacy of industrial production as a primary inspiration for designers' work in contemporary society and its historical contribution to environmental instability. It is also easier to propose transformative interventions through design and its material, technical, social and deductive possibilities. Their projects have been presented, published and acquired in the permanent collection of the MoMA in New York, the Centre Pompidou in Paris, the Triennale in Milan and many other museums.

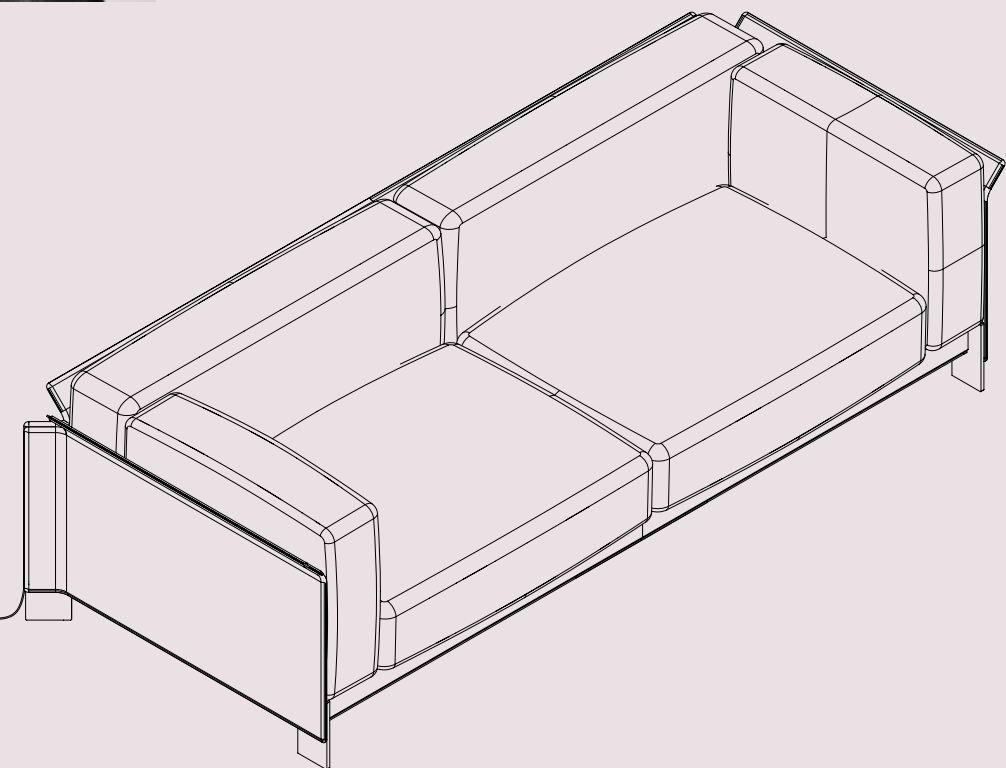

“The project stems from a desire to embrace contemporary life by drawing inspiration from the rational concreteness of rural Puglia.”

designed by
Sabine Marcelis

block

Block is a sofa/sculpture that visually reflects the harmonious synthesis between brand and designer - the background of Marcelis, a born sculptor, combined with the sinuosity and comfort of Natuzzi. A comfort which, owing to the front wheels, follows us everywhere, thus embracing the philosophy of liquid space, of the movable, where that which is needed is always where it needs to be.

A monolithic base in natural bamboo accommodates a generous, abundant padding, which almost seems to overflow and pour out.





Block three-seater sofa shown in Stylish leather.
H65 - W280 - D96 cm
H26 - W110 - D38"
Patio coffee table.
Arancio vases.

The exploration of materials, the study of geometries, the attention to the relationship with light - all themes dear to the Dutch designer - give life to an object with an innovative aesthetic and surprising dynamism. **The Patio coffee table**



patio

designed by
Sabine Marcelis

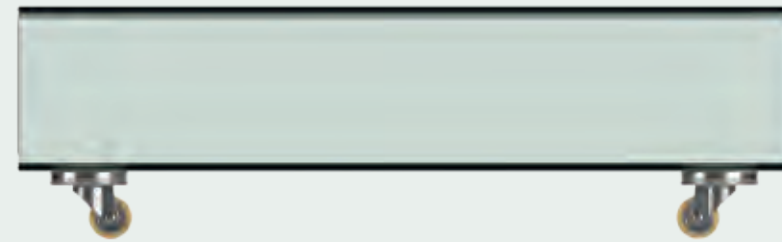

The ideal addition to fluid spaces, the **Patio** coffee table is an ode to lightness - enhanced by pure shapes and the glass structure.

Patio coffee table shown in clear Stopsol glass.





Sabine Marcelis, a young Dutch designer who has won prestigious awards such as the 2019 Design Prize in the 'Newcomer of the year' category and the Wallpaper Awards for 'Designer of the year 2020', continues her research in her Rotterdam studio into pure forms that enhance and exalt the special features of different materials. This allows her, in her collaborations with companies, to intervene early on in the production process, achieving surprising new effects: her designs are not simply static works, but real visual and sensory experiences in which experience itself becomes function, with a sophisticated and unique aesthetic.

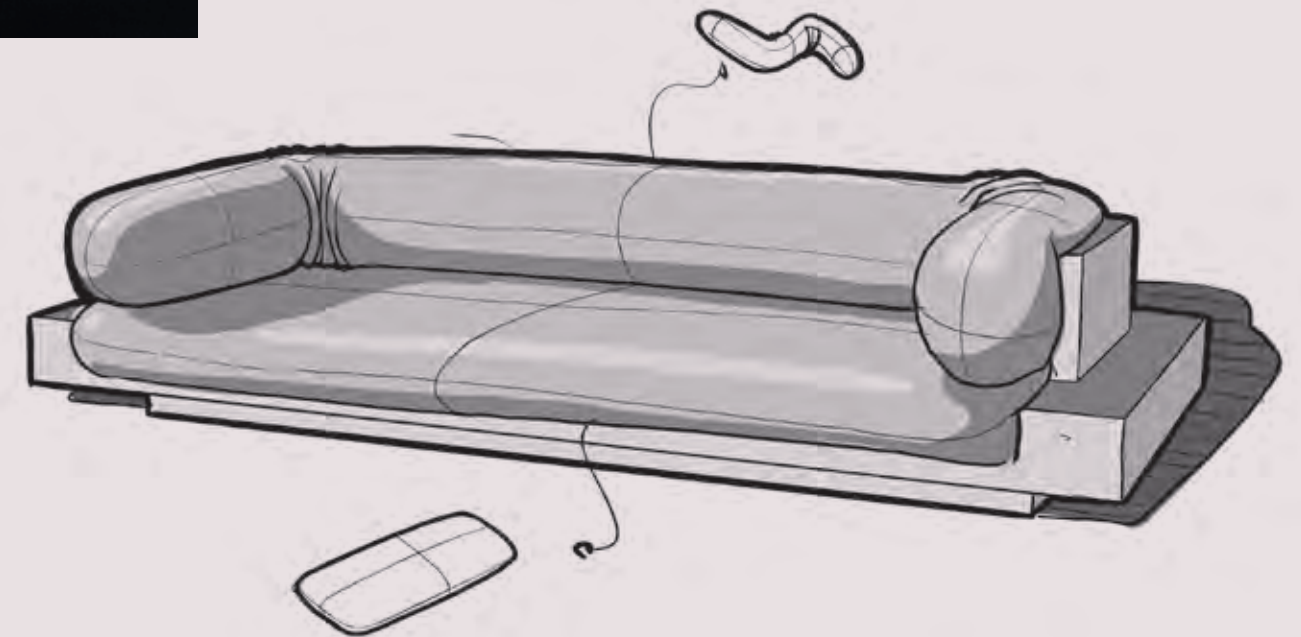

“In the new domestic space, which is fluid and constantly changing, objects must also evolve, offer us more functions and follow us wherever we go.”

designed by
Natuzzi Design Center

bolder

With Bolder, the continuous innovation of the “comfort experience” - part of the Natuzzi DNA - reaches new heights. The broad and generous seats conceal a mechanism consisting of two motors which separately control the headrest and the footrest. A modular and versatile system that adapts to all requirements and lifestyles.





Bolder sectional sofa
shown in Stylish leather.
H95 - W328 - D296 cm
H37 - W129 - D117"
Dodi armchairs.
Herman coffee table.
Herman accent and pouf.
Luce rug.

The headrest can be adjusted
and raised electronically and
tilted forward manually to
achieve the best TV position.



Available in various angular and linear versions, with a recliner function that can be activated separately on each seat, or without.



designed by
Marcel Wanders Studio

Completing the light,
harmonious silhouette of
Euforia is the base made of
shiny black metal.

euforia

Euforia pays tribute to the olive leaf, whose elegance already resembles an object of design. The sofa retains its essential, soft aesthetics, replicated in the armrests and backrests with a slightly flared configuration, forming a type of plant-like frame around the seat. A modular system to meet the needs of a multifunctional, elegant and compact living room.



Euforia sectional sofa
shown in Stylish leather.
H75 - W325 - D230 cm
H30 - W128 - D91"
Skyline coffee tables.
Trullini air scents.



The **Skyline** coffee table plays on a recreation of urban landscapes by combining different materials, heights and sizes.

The modular nature of the sofa is enhanced by integrated shelving between the seats. Planning that includes small spaces is a challenge and an opportunity for new furnishing solutions.



designed by
Massimo Iosa Ghini

juno

The soft, enveloping aesthetic of Juno alludes to and pays tribute to the historic Natuzzi models, whilst also introducing a type of 'neo-humanism' in its design, in which the person returns to the centre of the project and completes it. Inclusion, a basic value of the Mediterranean lifestyle, upgrades the role of the sofa, which welcomes and embraces us by adapting totally to us.

The harmony arises from an encounter between the design of the seat - so inviting - and the rigid flaps that define the lines of the backrest and armrests, giving the sofa an image of balanced subtlety.



Juno three-seater sofa
shown in Nabuk.
H85 - W283 - D105 cm
H33 - W111 - D41"
Herman coffee table.
Pumo craft item.
Magna Grecia rug.



The coffered ceilings in
the Baroque churches of
Salento come to life in the
Magna Grecia rug.

The covering folds into curves beneath the weight and shape it accommodates. The seams emphasise the natural, almost floral lines along the profile, without interrupting the generous volumes.



Considered one of the masters of Italian architecture and design, since the '80s **Massimo Iosa Ghini** has been involved in the innovative work of the design avant-garde with the Memphis group and with Bolidismo, a movement that he founded. Iosa Ghini Associati was founded in 1990 and operates in Milan, Bologna, Moscow and Miami, designing residential, commercial and museum architectural spaces, cultural installations and public transport facilities. These projects have received awards such as the Good Design Award, the Red Dot Award and the International Architectural Award.

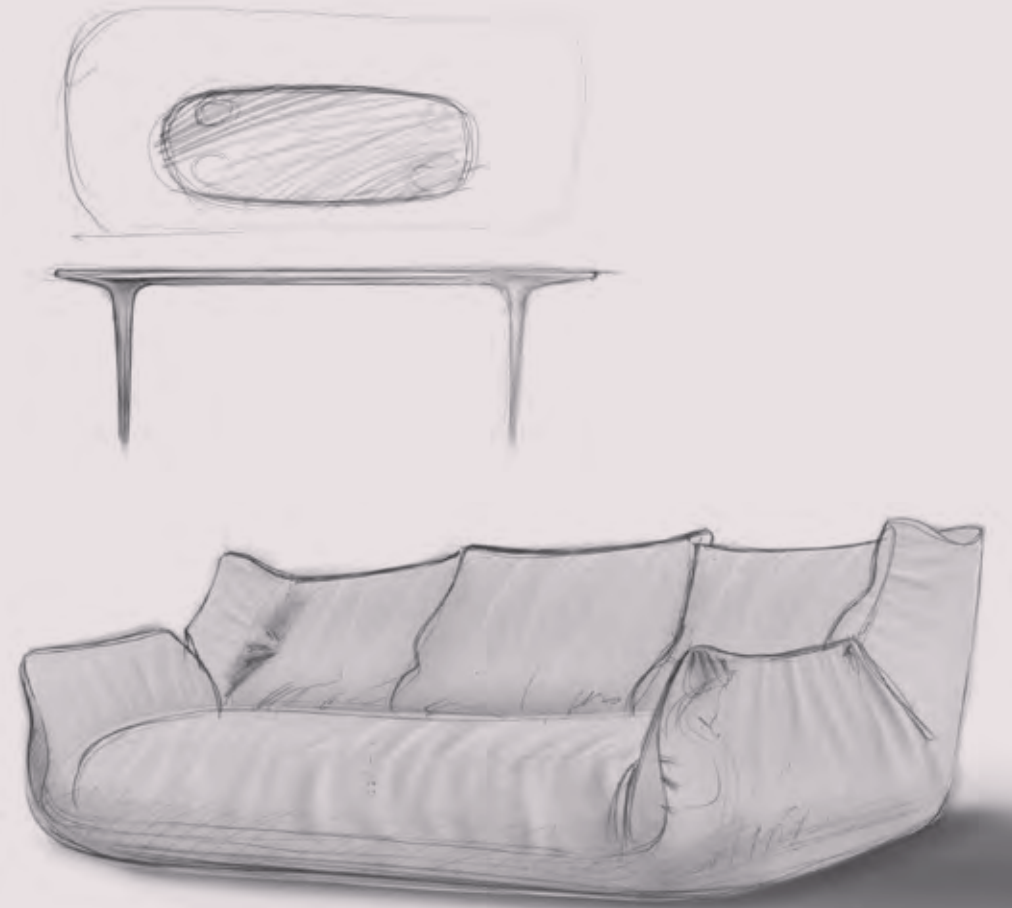

“On Juno, you don’t sit down in a composed fashion, but you throw yourself into it... with a dynamic gesture, precisely because you are sure to find the softness of a natural and welcoming womb.”

designed by
Elena Salmistraro

calilla

As the name implies, the Posidonia collection pays tribute to the Mediterranean, which has always been a source of inspiration for Natuzzi Italia. Calilla is a recliner sofa enclosed within a protective shell / casing that folds around the cosy seats and features headrests that mimic the shape of marine sponges. Enhancing the image is an exclusive fabric that captures the distinctive sea coral pattern.



Calilla three-seater sofa shown in Premium fabric / Stylish leather. H93 - W240 - D102 cm
H37 - W94 - D40"
Dysidea cushions.
Frost coffee table.
Ciambotte set of trays.
Ensis armchair.
Gorgonia rug.

A design like a drop of dew. The soft, sophisticated elegance of the **Frost** coffee table.





The **Gorgonia** rug features a combination of symbols inspired by tuff caves and aquatic elements.

Tradition, hand-crocheted decoration, and the concept of a sustainable future coexist, with fibres derived from recycled PET.

ensis

designed by
Elena Salmistraro



This Mediterranean backdrop gives rise to reworked suggestions in the form of armchairs such as the **Ensis**, which offers versatility in an imaginative, visionary and playful key.

Ensis armchair shown in Stylish leather and Premium ByBorre fabric. Metal structure in brass finish.



Puperita pouf shown in Premium ByBorre fabric. Metal structure in brass finish.

anemonia

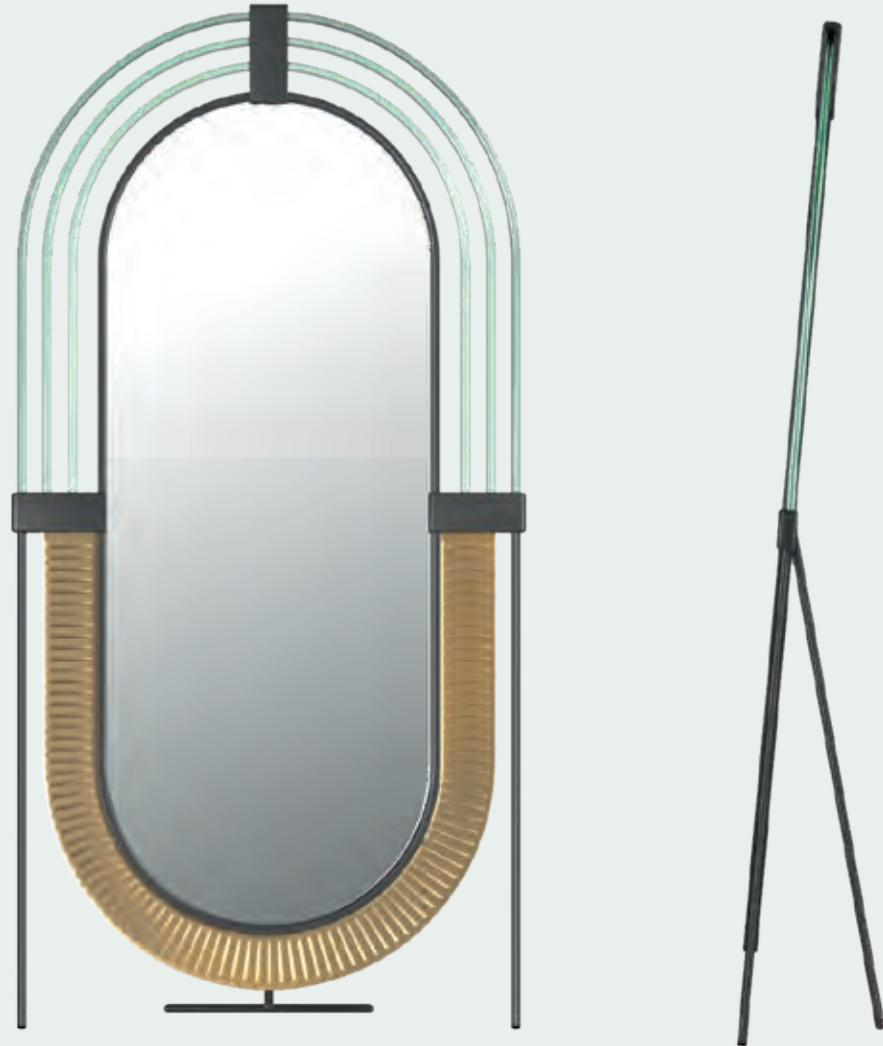

designed by
Elena Salmistraro

The **Anemonia** combines geometric and organic patterns from the marine environment. A mirror that can either be free-standing or wall-mounted, horizontal or vertical, depending on how you see the world and its reflection.

Anemonia mirror with metal structure in black and matt gold - frame enhanced by 3 metallic tubes in mint green.



The motion mechanisms concealed inside the backrest provide total, personalised comfort and create a surprising visual effect.



Milanese artist and product designer **Elena Salmistraro** has a highly recognisable and unique style, which, in 2017, won her the "Salone del Mobile Milano Award" as "Best newcomer designer" and has led to collaborations with major Art and Design Galleries such as Dilmos, Rossana Orlandi, Camp Design Gallery, Subalterno1 and Secondome. Her works, which straddle the boundary between illustration, design and visual arts, aim to stimulate the emotions and sensitivity of the end user. Her distinctive hallmarks include a harmonious search for forms and great attention to detail: an excess of graphic symbols gives the object a stereoscopic image, transporting it into a realm suspended between fantasy and reality, between anthropomorphism and primitivism.

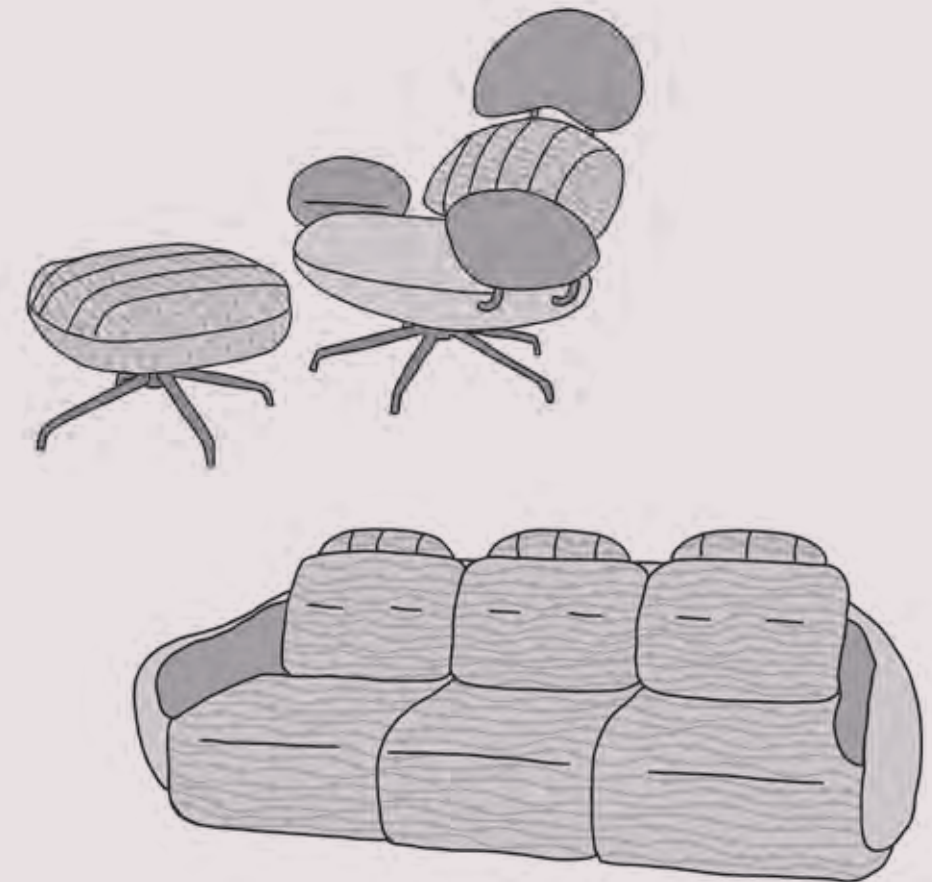

“My work feeds on graphic elements, which are broken down, reworked and reformed to give life to original, conscious and speaking objects. In this case, the Apulian sea provides these objects.”

designed by
Mauro Lipparini

sohay

Natuzzi Italia offers an original new interpretation of its pioneering “comfort experience” with Sohay. A sofa of archetypal forms - it is reminiscent of the dry stone walls of the Apulian countryside - which thanks to an innovative mechanism can be transformed into a bed by lowering the backrest and sliding the seat onto its base.

The armrest is detachable and can also be used as a pillow in the bed version.





Sohay sofa shown in Essential leather and in Premium fabric.
 H85 - W200 - D96 cm
 H33 - W79 - D38"
Feudo coffee table.
Colosseo floor lamp.
Sophia B rug.

The handle between the seats permits them to slide thanks to a hidden mechanism.

Simplicity and linearity enclosed in a metal cylinder.
 The **Colosseo** illuminates the setting, even when switched off.



designed by
Natuzzi Design Center

sophy

With its sophisticated aesthetic and contemporary and minimalist elegance, Sophy blends design and function to delight all the senses. Its welcoming forms conceal next-generation recliner mechanisms with soft touch technology and the Zerowall space-saving system. Be seduced by excellence.





Sophy three-seater sofa shown in Essential leather.
H78 - W306 - D110 cm
H31 - W120 - D43"
Dysidea cushions.
Anteprima armchair.
Cava coffee table.
Urchin vase.
Barisano rug.



A simple touch transforms the seat into a chaise-longue waiting to welcome you

Compact and refined, **Anteprima** will fit in anywhere, from the lounge to the bedroom.

designed by
Lorenza Bozzoli

timeless

Timeless captures the blossoming of a flower and holds that moment forever. Natuzzian harmony translated into elegant, subtle shapes like the wings of a butterfly. Modules with soft, deep seats give life to ever-changing configurations, revealing the eclectic taste of Bozzoli that stems from the world of fashion.

Tailored cut, generous, enveloping line, and sinuous, sophisticated asymmetrical shapes. The emblem of a Made in Italy range that continues to create inexhaustible elegance.



Timeless sectional sofa
shown in Premium fabric.
H80 - W420 - D295 cm
H31 - W165 - D116"
Feudo coffee table.
Trullini air scents.
Sophia B rug.

Timeless reinterprets visual
comfort and the concept of
Mediterranean slow living
connected with the beauty of
nature, all foundations of the
Natuzzi Italia style.





feudo

designed by
Mauro Lipparini

A coffee table with pure, geometric, sculptural shapes and adjustable height.
Feudo, the beauty of essentiality.

Feudo coffee table in natural Ash wood with white Travertino stone top or glossy white lacquered top.





Lorenza Bozzoli lives and works in Milan, where she was born. After attending the Brera Academy of Fine Arts, she moved to New York to launch her career in fashion with her first self-produced collections. Back in Milan, she began working with Elio Fiorucci and collaborated with major clothing brands. Her focus then shifted to the design world, which recognised her talent and extremely personal style. A series of collaborations with Alessi, Pomellato, Slamp and other brands, both Italian and international, led her to found, in 2018, the Lorenza Bozzoli Couture brand, which produces high-end contemporary furniture accessories.

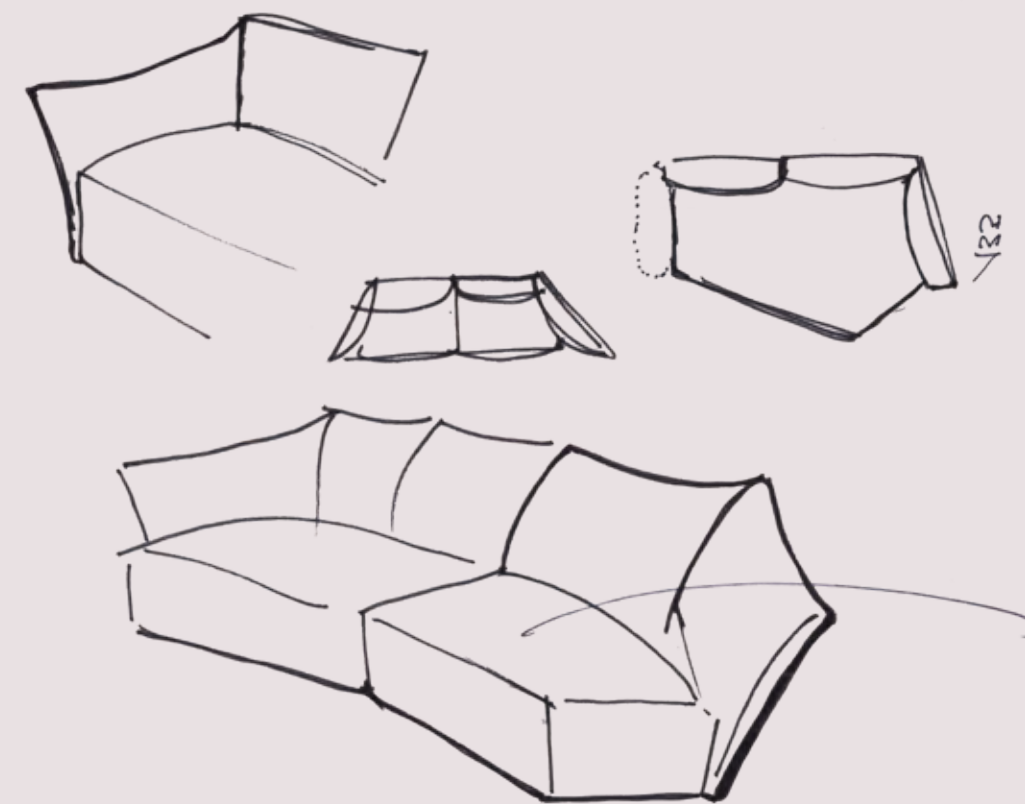

“Timeless is a tribute to blossoming, to rebirth, to the beginning of a new positive life cycle in the name of well-being.”

designed by
Natuzzi Design Center

valzer

As its name suggests, elegance and lightness are the overriding traits of Valzer, a sleek, compact sofa with a contemporary feel and innumerable possible configurations.

The various positions of the armrests and headrest multiply the comfort options while the open base exalts the minimalist and ergonomic design.





Unusual geometric shapes and exquisite materials. The irresistible allure of the **Chocolat** coffee tables.

Valzer sectional sofa shown in Essential leather. H77 - W304 - D304 cm H30 - W120 - D120" **Dysidea** cushions. **Chocolat** coffee tables. **Pumo** craft items. **Sophia B** rug.

Adjustable lever concealed in the armrest for ideal support at all times.

The headrest can be adjusted to different positions – for relaxation, reading or conversation.





dysidea

designed by
Elena Salmistraro

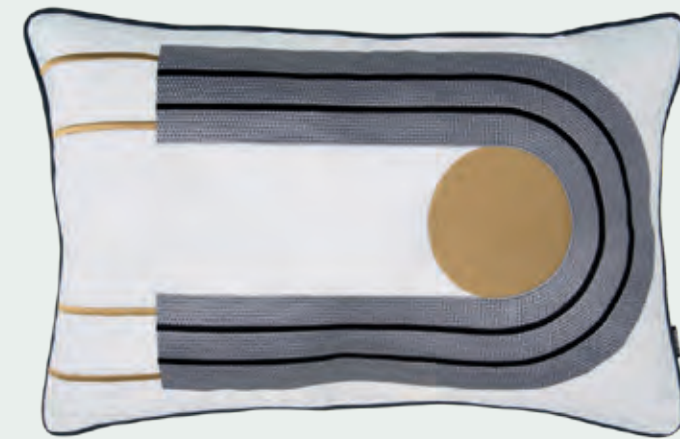

Undulating, abstract marine elements create objects with a harmonious aesthetic. **Dysidea** cushions from the Posidonia collection.

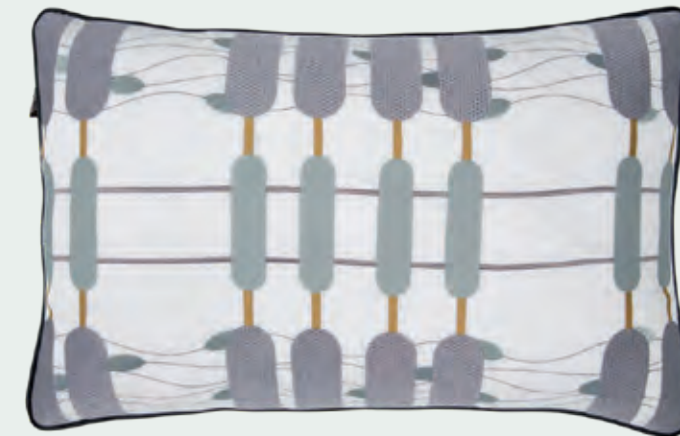

designed by
Natuzzi Design Center



iaggo

The artisanal workmanship comes together with the innovation, whose prime objective is to heighten comfort levels. Linear and geometric shapes hide exclusive motion systems allowing you to customise everything to suit your own needs.

Exquisitely sewn "pinched seams" highlight the peerless quality of the coverings.

lago chaise sofa
shown in Essential leather.
H75/99 - W303 - D169 cm
H30/39 - W119 - D67"
Penelope armchair.
Ido coffee table.
Globes rug.
Dami floor lamp.



Reclining footrest and headrest - the "made to measure" comfort you're searching for.



Watch lago sofa in motion

The incredibly versatile design of the **lago** sofa allows for personalisation so you can achieve a result that suits your style, space and comfort requirements down to the ground.

Here are some suggested arrangements.



Three-seater sofa
H 75/99 - W 308 - D 111 cm
H 30/39 - W 121 - D 44"



Chaise sofa
H 75/99 - W 303 - D 169 cm
H 30/39 - W 119 - D 67"



Sectional
H 75/99 - W 313 + 227 - D 111 cm
H 30/39 - W 123 + 89 - D 44"



Sectional with end unit
H 75/99 - W 324 + 227 - D 111 cm
H 30/39 - W 127 + 89 - D 44"



Sectional with chaise-longue
H 75/99 - W 391 + 227 - D 111 cm
H 30/39 - W 154 + 89 - D 44"

globes

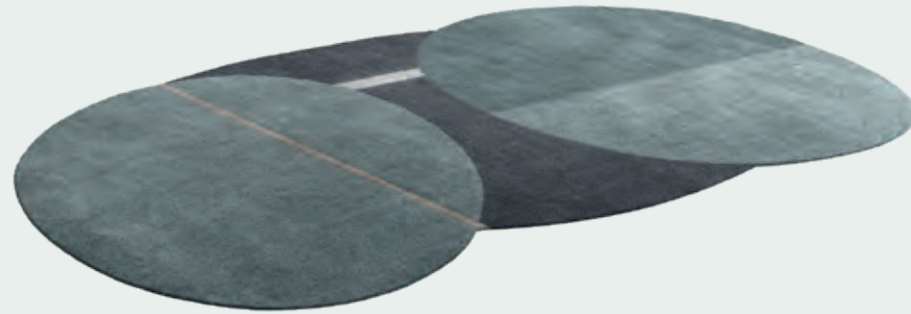

designed by
Carlotta Fortuna

Apparently overlapping forms and surfaces create an interplay of imaginary shadows. **Globes**, the expressionist rug.

Globes rug shown in blue.

penelope



designed by
Mauro Lipparini

With its plush reassuring design, **Penelope** waits patiently for you to return home and is always ready for you to sink into.

Penelope armchair shown in Performance fabric with rear feet in wood and front feet in black chrome metal.



iago

iago sectional with end unit shown
in Premium microfibre
H75/99 - W313 - D340 cm
H30/39 - W123 - D134"
Skyline bench.
Skyline coffee table.
Pumo craft items.
Sophia B rug.
Dami floor lamp.
Decorative cushions.





Lots of different units for ever-changing arrangements. Imagination in the driving seat.

Reclinable footrest and headrest allow you to create your perfect comfort.



pumo ceramic flower bud



designed by
Natuzzi Design Center

A wish of happiness,
prosperity and fertility.
Pumo, the lucky object of
Apulian tradition.

Pumo craft items shown in
gold-and-banana ceramic
and whiskey glass.



designed by
Manzoni&Tapinassi

kendo

A perfect combination of modularity, fine craftsmanship and curated design, Kendo's refined personality is further enhanced by exquisite detailing, like the solid-wood base embellished with a sleek metal insert. A distinguishing feature that takes on the guise of an oriental mark.





Kendo three-seater sofa shown
in stylish thick leather.
H77 - W242 - D104 cm
H 30 - W95 - D41"
Viaggio armchair.

Kendo coffee table.
Dandy candle holder.
Kendo floor lamp.
Seti rug.





kendo

designed by
Manzoni&Tapinassi



Wood and metal match quite perfectly - and everything slots seamlessly into place, like tiles in a domino set. The Levantine elegance of the **Kendo** coffee table.

Kendo coffee table shown in smoked oak wood with brass metal insert.



kendo

designed by
Manzoni&Tapinassi



Like a **Kendo** sword, the eponymous lamp creates a clever contrast between the warmth of wood and the lustre of metal.

Kendo floor lamp shown in walnut with brass insert and white lampshade.





viaggio

designed by
Manzoni&Tapinassi



In any setting, whether home or office, **Viaggio** is true to its name: a journey into relaxation.

Viaggio armchair shown in Trendy fabric and wengé wooden feet.



The incredibly versatile design of the **Kendo** sofa allows for personalisation so you can achieve a result that suits your style, space and comfort requirements down to the ground.

Here are some suggested arrangements.



Sectional
H77 - W278 - D327 cm
H30 - W109 - D129"



Three-seater sofa
H77 - W242 - D104 cm
H30 - W95 - D41"



Chaise sofa
H77 - W342 - D168 cm
H30 - W165 - D66"



Sofa with end unit
H77 - W104 - D242 cm
H30 - W41 - D95"



Sectional with end unit
H77 - W322 - D242 cm
H30 - W127 - D95"

kendo

Kendo sectional with end unit
shown in Premium fabric.
H77 - W322 - D242 cm
H30 - W127 - D95"
Kendo coffee table.
Pumo craft item.
Sophia B rug.
Blossom armchair.





blossom

designed by
Claudio Bellini



The stylish '50s are in full bloom again. The superbly comfortable and slightly retro aesthetic of **Blossom**.

Blossom armchair in Essential leather with wengé wooden feet.



designed by
Manzoni&Tapinassi



herman

Reminiscent of a fish tail, the external metal support that embraces and clasps the backrest and seat is a standout feature on this piece. The various units can be arranged to create in-line, corner or peninsula compositions to be completed with tables in a variety of shapes and sizes.





Herman chaise sofa shown in Stylish leather.
H77 - W327 - D155 cm
H30 - W129 - D61"
Viaggio armchair.
Herman coffee table.
Silo vases.
Magna Grecia rug.
Decorative cushions.

herman

designed by
Manzoni&Tapinassi



A groundbreaking project in terms of design and versatility. The **Herman** coffee table.

Herman coffee table shown with bronze mirrored top and frame in bronze metal.



magna grecia

designed by
Marcel Wanders studio

The coffered ceilings in the baroque churches of the Salento peninsula are given an airing in the **Magna Grecia** rug.

Magna Grecia rug shown in blue and taupe pattern.



herman

Herman sectional with end unit shown in Premium fabric.
H77 - W276 - D357 cm
H30 - W109 - D141"
Herman coffee table and pouf.
Decorative cushions.
Sophia B rug.

This sofa can be personalised with a grosgrain detail (in either a tonal or contrasting shade) which further enhances its innate charm.





herman

designed by
Manzoni&Tapinassi



The minimal design makes the **Herman** coffee table easy to be combined with any seating systems.

Herman coffee table shown with invisible grey marble top and metal frame with pewter finish.

couture

designed by
Manzoni&Tapinassi



Sharp geometrical shapes and sleek volumes for an oasis of relaxation and comfort. This is no mirage; it is the **Couture** swivel armchair.

Couture armchair with swivel base shown in Stylish leather.



herman

Herman sectional with end unit shown in Premium fabric.
H77 - W348 - D265 cm
H30 - W137 - D104"
Herman coffee table.
Pumo craft item.
Conca swivel armchair.
Sophia B rug.

The plushness of the sofa brings to the fore the beauty of Water - the exclusive 3D fabric made by BYBORRE which is a combination of premium-quality wool and recycled PES.

The sleek design of the armrests with elegant flat-felled seamwork which is invisible from the outside.



designed by
Mauro Lipparini

buddie

Buddie is a contemporary take on the living room with a versatile system that can be endlessly rearranged, as well as backrests and seat cushions which slot smoothly into each other in a triumph of overlapping shapes that is not only aesthetically pleasing but also functional.



Buddie three-seater sofa
shown in Premium fabric.
H77 - W320 - D100 cm
H30 - W126 - D39"

Margaret armchair.
Ika coffee tables.
Urchin vases.
Decorative cushions.



Water - the exclusive BYBORRE 3D fabric, is a combination of premium-quality wool and recycled PES.

BYBORRE®



Borre Akkersdijk is a Dutch textile designer and the founder of the fabric-innovation studio BYBORRE. Born in Wamel, Netherlands, he studied fashion design at the Fashion Institute of Technology in New York and received a Bachelor's in Man and Identity from the Design Academy Eindhoven in 2009 before working at the Paris-based design consultancy bureau Studio Edelkoort. He started BYBORRE in 2010, initially consulting for brands such as Nike and Louis Vuitton before deciding to focus solely on the development of his now signature 3D knitted fabrics. In 2012, he won the Young Designer of the Year award at the Dutch Design Awards. Research into the future of fashion and integrated technology resulted in presentations at South by Southwest, Beijing Designweek and Salone del Mobile Milano, as well as publications in the Wired magazine and Fast Company Magazine. Today, BYBORRE is a landmark studio filled with a wide range of machines and a team of specialists from all corners of the textile industry. The collaboration with Natuzzi, the first with a furniture company, represents the kind of disruptive intuition that defines the creative vision of Pasquale Junior Natuzzi. It is based on his belief that innovation should not be limited to collaborations with the leading figures and most prolific minds of contemporary design, but should lead the company to rethink their production methods, starting from their very foundations, with a new, radical approach that combines the most outstanding quality and sustainability. An approach in which process and product are equally important. In this regard, BYBORRE has proven to be a perfect partner. By studying and embracing Natuzzi's brand identity, the Dutch factory has created WATER, an exclusive fabric that embodies the heart and soul of Apulia, the muse that inspires Natuzzi's entire way of thinking. A 3D™ fabric that is unique worldwide, featuring a pattern that evokes the continuous movement of water, conveying all of Pasquale Junior's love for the sea. A knitted fabric made with a blend of the finest wools and recycled PES, which makes it extremely resistant and durable, yet luxurious, comfortable and totally eco-friendly. A fabric that embodies Apulia's heritage and the brand's identity, testifying to Natuzzi Italia forward-thinking vision.

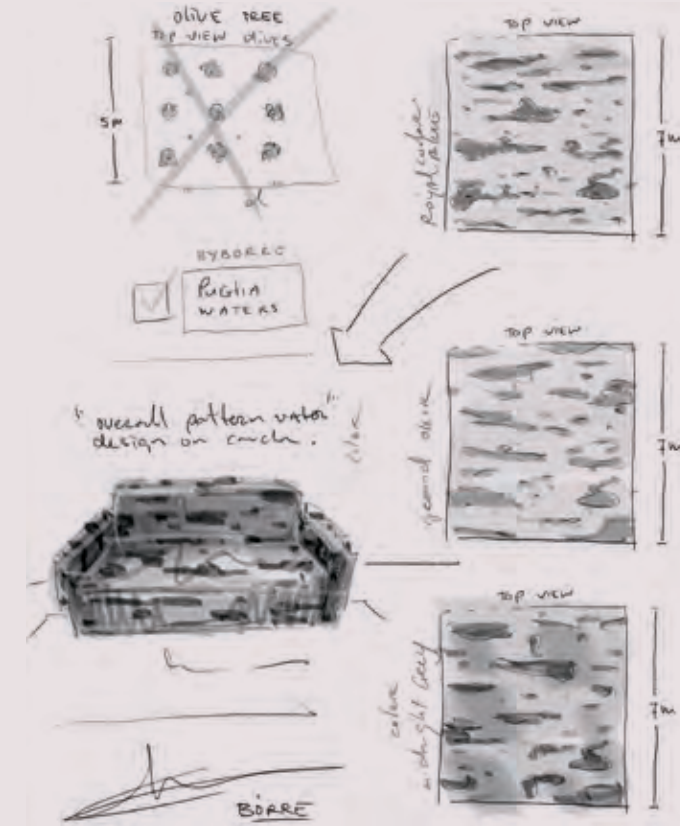

“By thinking about the future of people and the planet, we are finding new ways to create quality, custom, and sustainable fabrics.”

ika

designed by
Mauro Lipparini



In Japanese **Ika** means "cuttlebone". A tribute to the beauty of organic forms designed by Nature.

Ika coffee tables shown with glossy beige -grey (central version) and glossy sand (accent version) top and metal frame in a bronze colour.





margaret

designed by
Mauro Lipparini



Margaret. An inviting concave leather silhouette makes this armchair as elegant as a sculpture.

Margaret armchair shown in a fixed version with a European walnut finish.



buddie

Buddie three-seater sofa
shown in Premium fabric.
H77 - W286 - D109 cm
H30 - W113 - D43"

Buddie chaise sofa
in Essential leather.
H77 - W317 - D164 cm
H30 - W125 - D65"

Ika coffee table.
Luce rug.





luce

designed by
Silvia Fanticelli

Mediterranean sunshine
and its reflection on a
windowpane. The refined
geometric pattern of the
Luce rug.

Luce rug shown in
terracotta wool and
Tencel®.



ika

designed by
Mauro Lipparini

The **ika** writing desk is the natural complement to the Buddie seats. For elegant settings that are halfway between a study and a living area.

Ika desk shown with a natural oak top featuring decorative bubbles in a matte lacquered grey – beige colour. Metal frame in bronze colour.



designed by
Maurizio Manzoni



dominio

Like the fortresses of Frederick II which dominate the landscape of Apulia, Dominio was born to elevate its setting with a sense of reassuring prestige. Once more, inspiration comes from the emblematic places of culture and tradition in this unique part of Italy.



Dominio sectional with end unit shown in Trendy fabric.
H77 - W327 - D155 cm
H30 - W129 - D61"
Tempo coffee table.
New Decò rug.
Pumo craft item.
Aromatic candle.



The tubular steel foot has the same shape as the backrest roll. Natuzzi's superiority emerges from a detail.



new decò

designed by
Myo Creative Lab

Twenties'-style patterning
and designs on exquisite
terracotta-hued inserts.
The gorgeous geometrical
shapes on the **New Decò** rug.

New Decò rug shown in grey
wool and terracotta Tencel®.

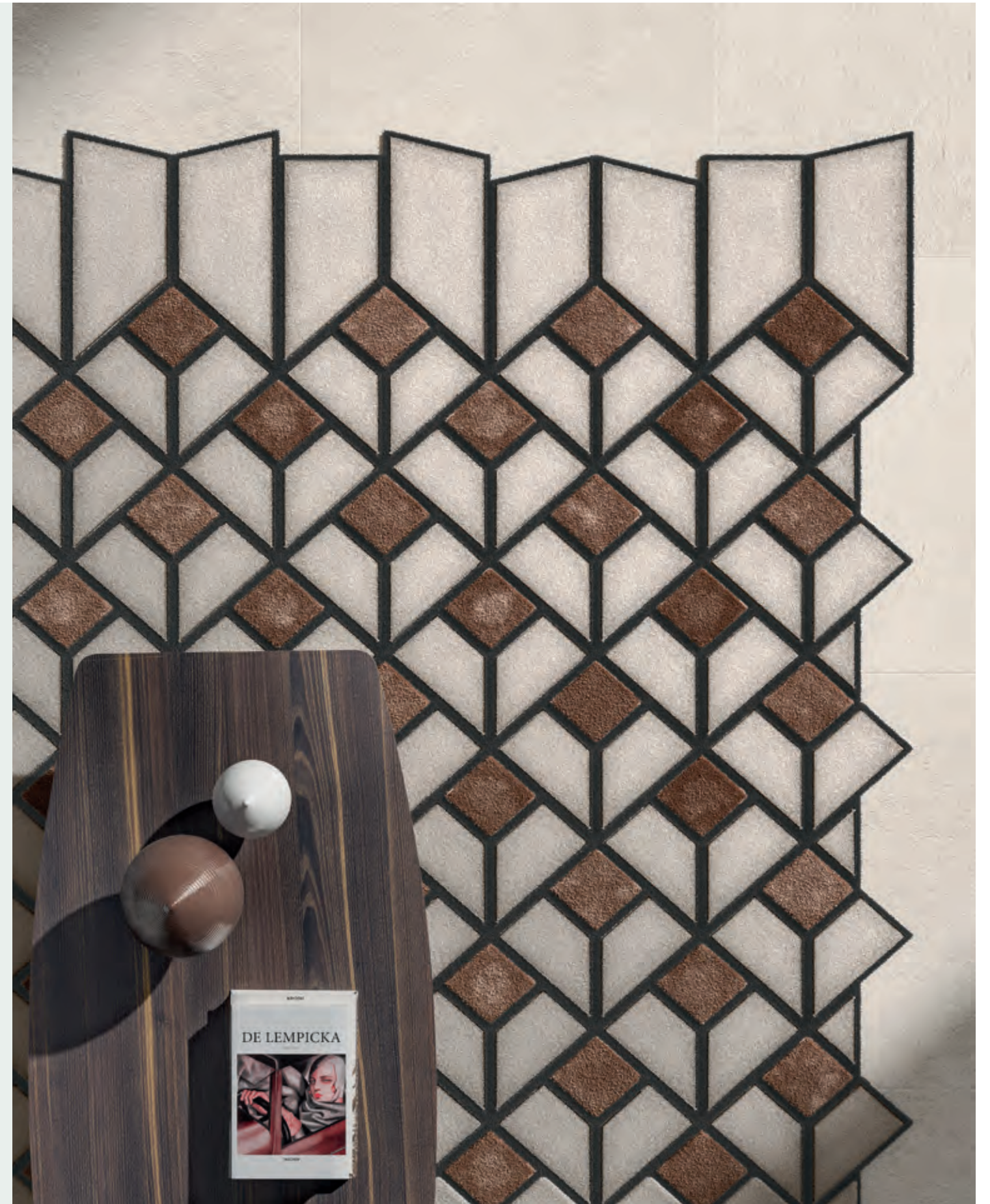
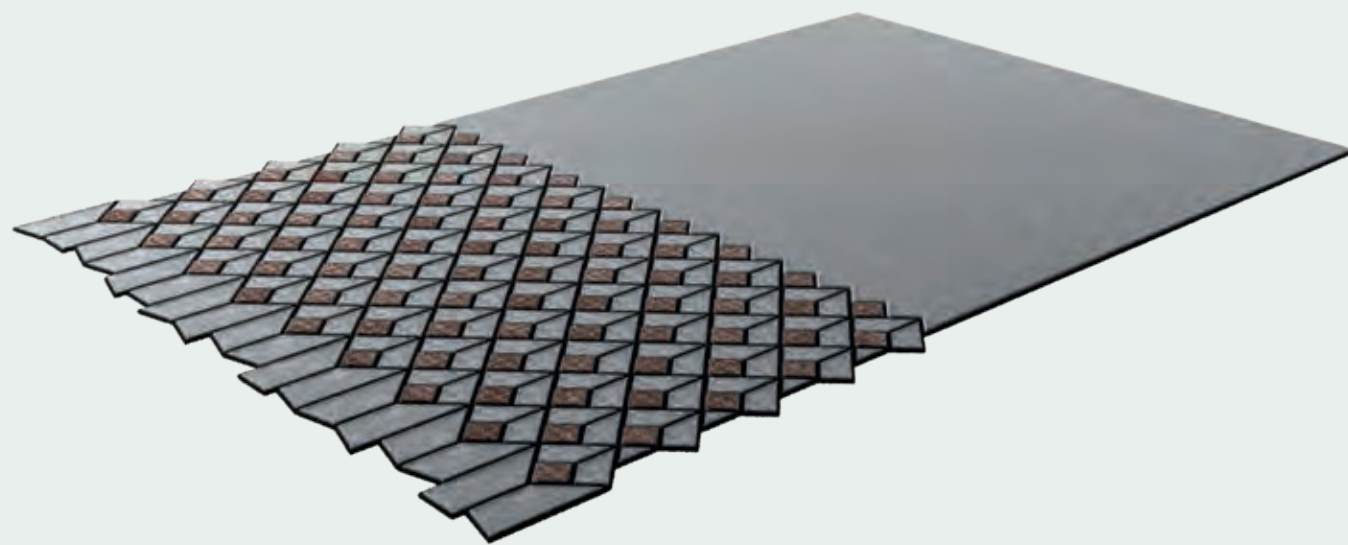

designed by
Claudio Bellini

long beach

A harmonious mix of design, premium materials and fine Italian workmanship. Invitingly comfortable, its armrests leave plenty of room for the seat cushions. The modular frame allows for endless rearrangements, from a simple and linear layout to a total-living concept with fully integrated low bookshelves.



Adapt the height of the feet to suit your style requirements. Versatility down to the tiniest detail.



Long Beach three-seater sofa shown in Performance fabric.
H78 - W234 - D102 cm
H31 - W92 - D40"

Herman coffee table.

colosseo



designed by
Mauro Lipparini

A metal cylinder that expresses linear simplicity. **Colosseo** shines its light, even when it is off.

Colosseo pendant lamp version shown in this page in black chrome and at the right in champagne finish.





affresco

designed by
Natuzzi Design Center

The pattern brings to mind the Nineteenth century tradition, while the washing gives it a highly contemporary look. The dual nature of **Affresco** - entirely handwoven.

Affresco rug shown in brown wool.



long beach

Long Beach sectional
shown in Stylish leather.
H78 - W335 - D319 cm
H31 - W132 - D126"
Herman coffee table and pouf.
Colosseo floor lamp.
Viaggio armchair.
Seti rug.



Double backrest cushions
filled with goose down.
Comfort - in true Natuzzi
Italia style.



Lots of different units
for ever-changing
arrangements. Imagination
in the driving seat.



designed by
Claudio Bellini

La Scala sectional with end
unit shown in Prestige leather.
H69 - W287 - D188 cm
H27 - W113 - D74"
Affresco rug.
Kendo table lamp.
Orfeo mirror.

la scala

La Scala gives a show-stopping spin to the most classic-looking of sofas, the Chesterfield. Claudio Bellini draws on superlative Italian workmanship and puts a chic modern stamp on this piece, which stands apart for the sharp edge that defines its sleek silhouette and contains the lofty button tufting.



Buttons lovingly attached by hand, one by one, in a shade that matches the chosen covering - either in leather or fabric.



la scala



La Scala dormeuse shown
in Stylish leather.
H69 - W92 - D165 cm
H27 - W36 - D65"
Marlene armchair.
Colosseo table lamp.
Affresco rug.



designed by
Mauro Lipparini



melpot

Apulia. A place where different races and cultures have always fused harmoniously, constantly filling a chalice of creativity and beauty that wells up and overflows. Melpot is a celebration of this melting pot which Natuzzi Italia epitomises in its designs and lifestyle.





Melpot sectional in Essential leather and Premium fabric.
H65 - W318 - D415 cm
H26 - W125 - D163"
Colosseo table lamp.
(92, 372, 813)
Melpot accent table and pouf.
Phantom table.
Frida chairs.
Chocolat mirrors.
Sophia B rug.



Some units are also available in quilted leather or fabric, which adds to the total versatility of this piece and makes for a host of different combinations.

Poufs, drawers, bookshelves and table tops - an ode to flexibility.

designed by
Mauro Lipparini



campus

With its measured and sophisticated design, Campus bespeaks timeless elegance lending itself perfectly to any living area and satisfying any furnishing or space requirements with its modular seating system and wide range of coverings devised to create ever new configurations.



Campus three-seater sofa
shown in Trendy fabric and
Gargano suede leather.
H82 - W246 - D100 cm
H32 - W97 - D39"

Campus coffee table.
Colosseo floor lamp.
Seti rug.



Frames of armrests and
backrests are also available
in suede leather with
unevenly woven patterning
in 7 colours. For an
astounding combination.





campus

designed by
Mauro Lipparini



Tops in a variety of shapes, materials and sizes allow for the creation of an elegant and sophisticated living area. The coffee tables from the **Campus** collection.

Campus coffee table shown in round version with glossy champagne frame and tobacco-brown ash-wood top.



campus

Campus sectional in Trendy fabric and Gargano suede leather.
H82 - W345 - D222 cm
H32 - W135 - D87"
Campus coffee table.
Pumo craft item.
Vico table lamp.
Campus dining table.
Valle chairs.
Sophia B rug.





pumo ceramic flower bud

designed by
Natuzzi Design Center



A wish of happiness,
prosperity and fertility.
Pumo, the lucky object
of Apulian tradition.

Pumo craft items shown
in a dark green and lime
flower version.

designed by
Marcel Wanders studio

sky line

Skyline is Marcel Wanders studio' tribute to a charismatic cosmopolitan globetrotter who comes back to Apulia, bringing with him a wealth of experience and inspiration. The classical overtones and the pleasant roundness of the Chesterfield give way to sharp New-York style architecture. This is where Via Appia and Park Avenue meet.





Skyline sofa with end unit shown in Essential leather. H80-96 - W290 - D108 cm
H31-38 - W114 - D43"
Skyline bench.
Lave armchair.
Skyline coffee table.
Urchin vases.
Sophia B rug.
Arch bookcase.
Decorative cushions.



Recliner, backrest and headrest mechanisms can all be adjusted with a single movement.



lave

designed by
Marcel Wanders studio



Inspired by fishing nets, **Lave** is light and sturdy at the same time - halfway between a rippled surface and a sculpted shape.

Lave armchair shown in Premium fabric with a glossy chromed base.

The Marcel Wanders studio is a leading product and interior-design studio located in the creative capital of Amsterdam. The studio has produced over 1,900 iconic product and interior-design experiences all around the globe for private clients and premium brands. Under Marcel Wanders and Gabriele Chiave's creative leadership and direction, the Marcel Wanders studio employs 52 design and communication experts. Regarded by many as an anomaly in the design world, the Marcel Wanders studio has made it its mission to "create an environment of love, live with passion and make our most exciting dreams come true."

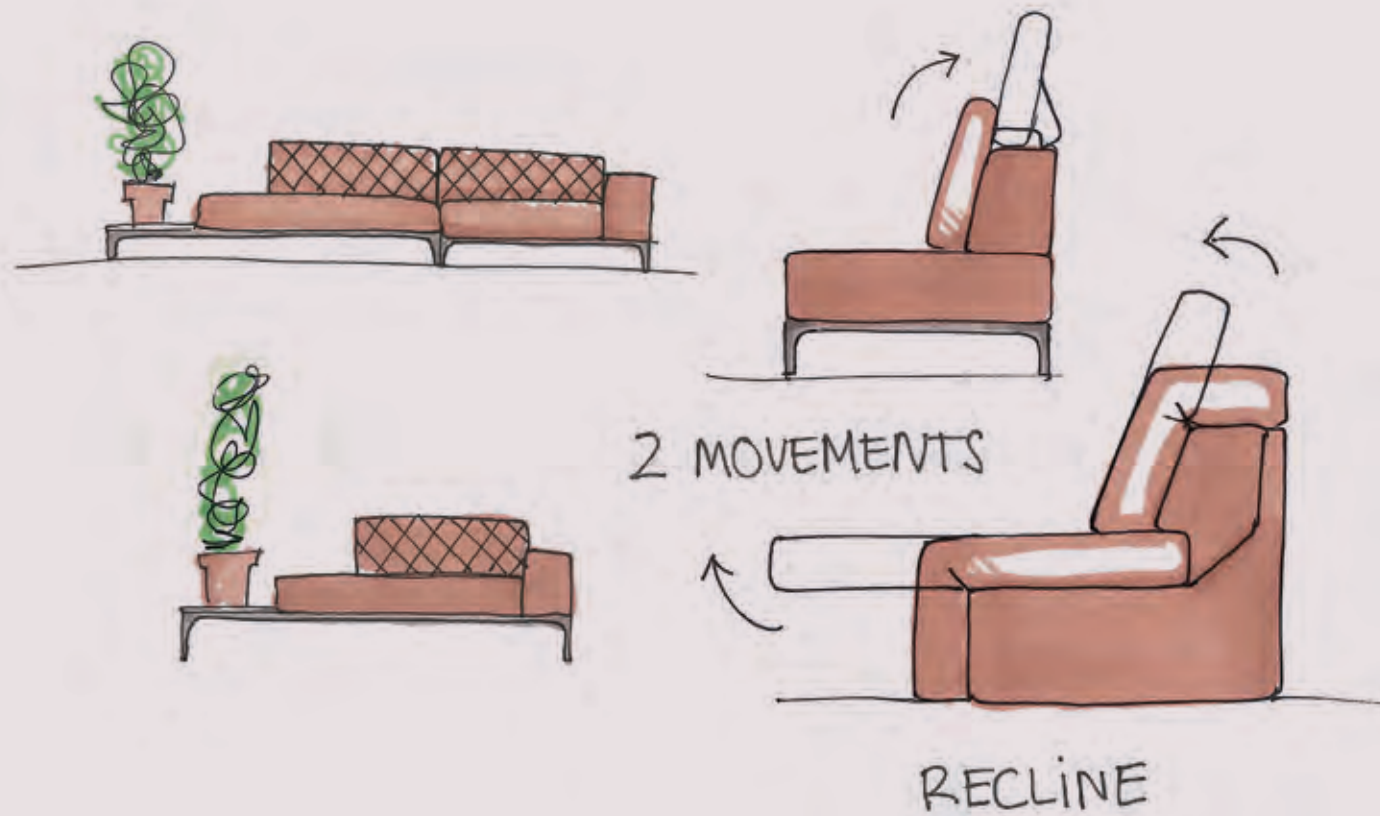
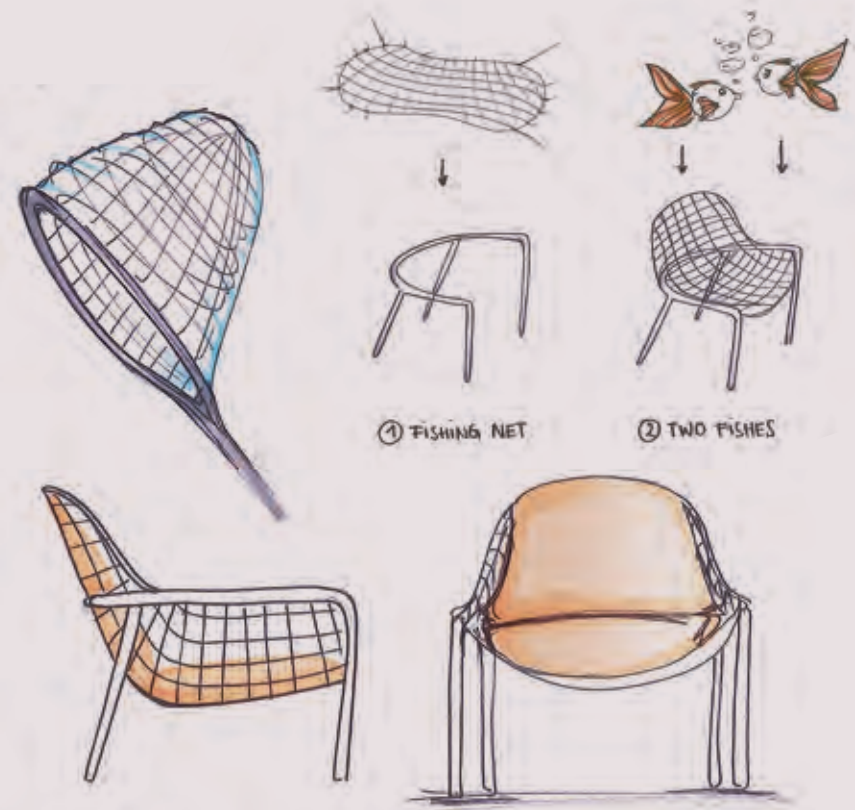

"I felt it was truly an honour and also a responsibility to really bring elements of Apulia and its atmosphere into the design. When we are able to incorporate the local culture and natural beauty of a region into a project, it allows the furniture to then create a sense of place".



dove

designed by
Marcel Wanders studio

Dove, created by Marcel Wanders and honoured with the Red Dot Award. Airy and dynamic in a graceful way, on the one hand it recalls its Italian heritage, on the other exudes cosmopolitan flair. Its additional backrest makes it relaxing to sit and lie on, ensuring exclusive Natuzzi Italia comfort in two different seated positions. A new icon of lightness and edginess - and an eye-catching centrepiece in any living space.

Dove chaise-longue version shown in Premium fabric with a glossy black metal base.



reddot winner 2020



luminarie

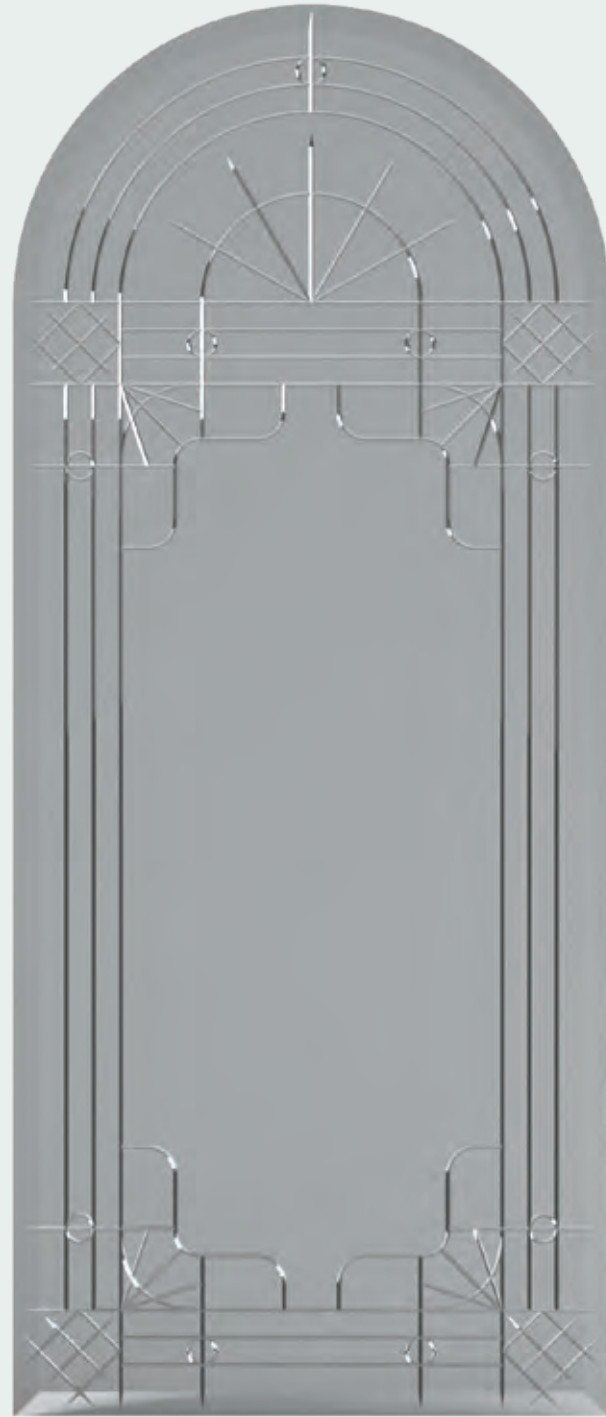

designed by
Marcel Wanders studio

The **Luminarie** mirror shows images of the sumptuous decorations to be found in the town squares of Apulia during celebrations.

Luminarie mirror shown with a smoky mirror finish.

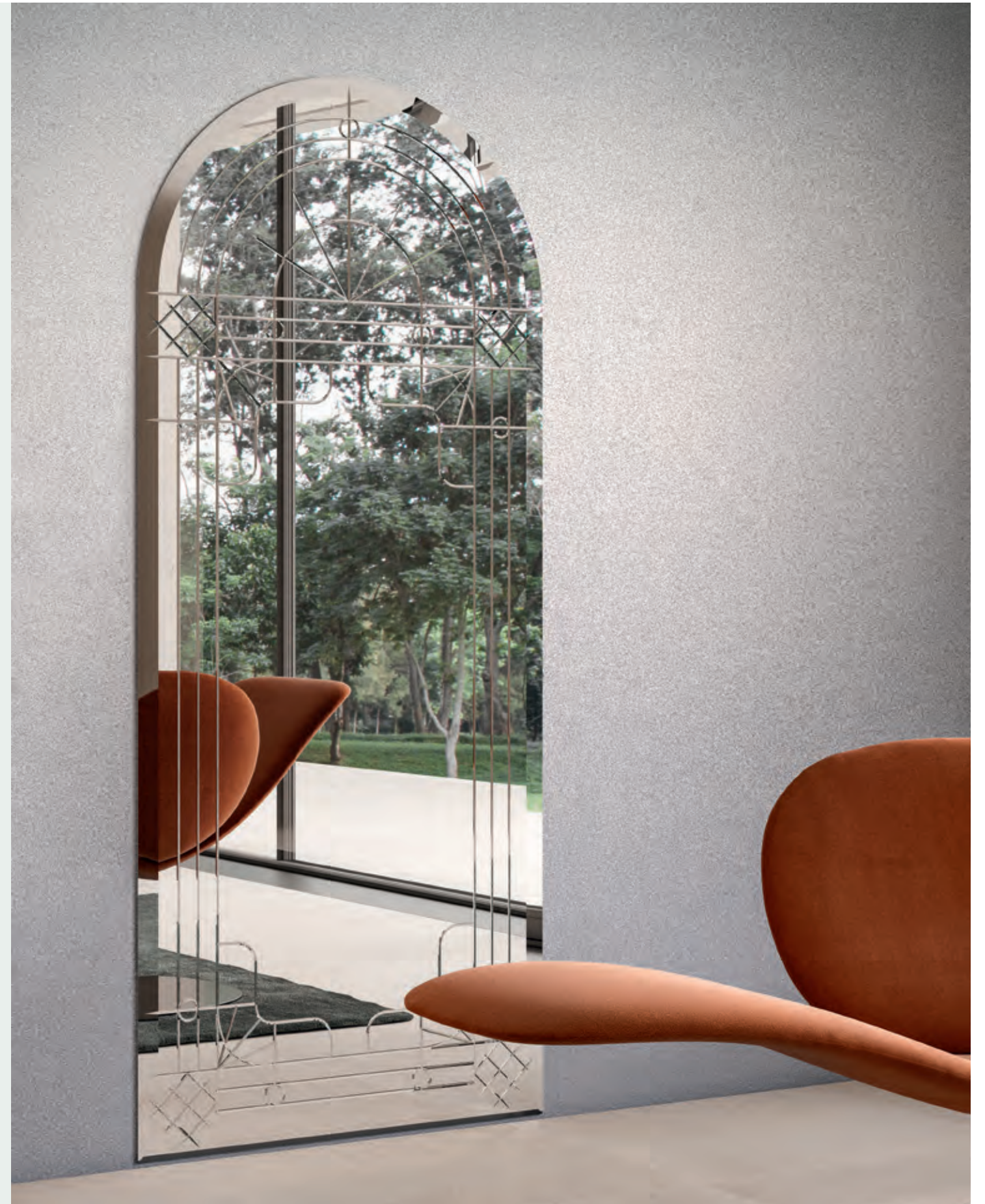

skyline

Skyline sectional with end unit in Premium fabric.
H80-96 - W332- D299 cm
H31-38 - W130- D117"
Skyline coffee table.
Dandy candle holder.
Sophia B rug.
Dami pendant lamp.



Even an arch foot can be an architectural feature on an open-base design.



skyline

designed by
Marcel Wanders studio



A toast to the Italian lifestyle, to its refined elegance.

The **Skyline** bar desk. **Skyline** bar desk shown with top in black granite and glossy black metal detailing on the frame.

arch

designed by
Marcel Wanders studio

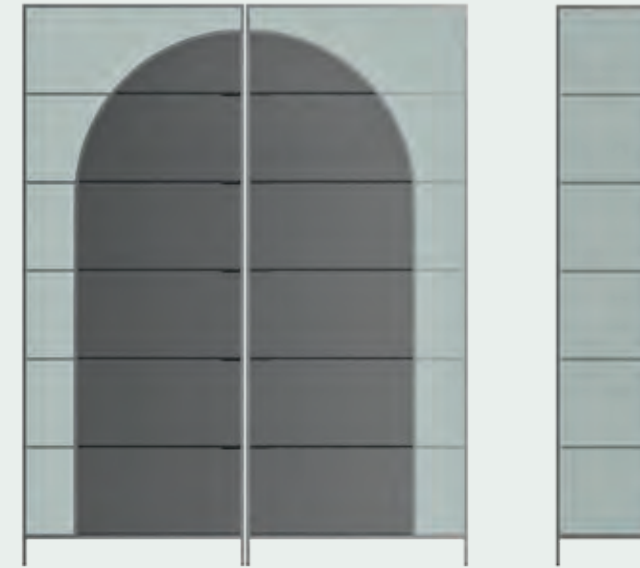

Architectonic elements from Apulian landscapes combined with mirrors and a clever use of translucent surfaces, creating a strong visual impact. The **Arch** bookcase.

Arch bookcase shown in glossy black chrome metal and mirrored smoky glass with black ash-wood shelf.

shield and dove

designed by
Marcel Wanders studio



The comfort of a chair and the sophistication of a stool. **Shield** and **Dove**, comfort goes glam.

Shield and **Dove** stools shown in Premium fabric and glossy black chrome.

dami

designed by
Marcel Wanders studio



The ancient carboys of Mediterranean tradition gleam in a new light cast by the **Dami** lamp.

Dami lamp shown with copper transmirror mouth-blown glass.

designed by
Claudio Bellini

pablo

The joyfulness and generosity of Mediterranean culture translates into a versatile seating system with a welcoming familiar design. Playing with heights and geometrical shapes, the armrests have been elevated with satin-finish metal rings on both ends, matching the feet in the same finish.



Experiment with backrests in different heights to enjoy the comfort you need at any given time.



Pablo two-seater sofa shown with low back in Performance fabric.
H80 - W186 - D94 cm
H31 - W73 - D37"

Pablo chaise sofa shown with high back in Essential leather.
H100 - W330 - D152 cm
H39 - W130 - D60"
Frost coffee table.

Pumo craft item.
Sophia B rug.
Decorative cushions.



conca

designed by
Claudio Bellini



Conca, a cocooning and reassuring alcove you can first lose yourself and then find yourself in. For endless lounging.

Conca armchair shown in Performance fabric with coffee-brown finish and wooden insert on tobacco-brown solid ash-wood base.



frost

designed by
Claudio Bellini

Like a droplet of dew on
spring blossoms. The
sleek and sophisticated
stylishness of **Frost**.

Frost coffee table shown
with grey fossena marble,
pewter metal frame and
extra-clear glass top.

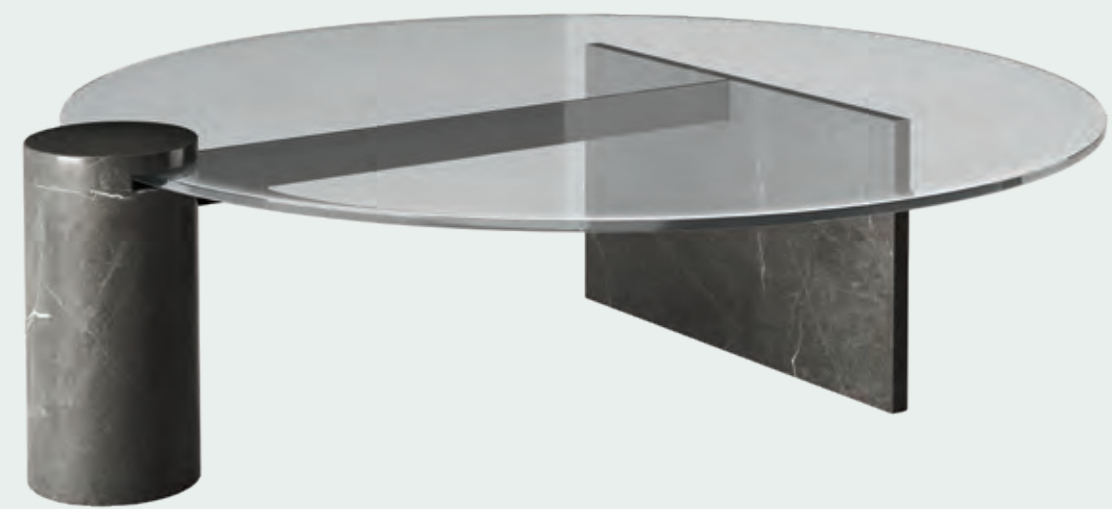

pablo

Pablo sectional with chaise-longue shown in Essential leather and Premium fabric. H100/80 - W455 - D229 cm
H39/31 - W179 - D90"
Frost coffee table.
Vico table lamp.
Fortuna sideboard.
Sophia B rug.



Seat units finished on all sides so that they can stand alone in various settings throughout the house.



designed by
Manzoni&Tapinassi

fidelio

Fidelio boasts a structure with high-tech lounging systems, including a soft-touch mechanism which activates the recliner function at the press of a button. An innovative sofa enhanced with superb artisanal workmanship - pinched seams revealing Natuzzi Italia's exquisitely processed leather. (694)

Fidelio three-seater sofa shown in Stylish thick leather.
H76-102 - W289 - D110 cm
H30-40 - W114 - D43"
Dove swivel armchair.

Dami floor lamp.
Sophia B rug.





Recliner mechanisms to customise the seat, backrest and footrest to suit your needs.



Watch Fidelio sofa in motion

A skilfully executed raw-cut seam - the mark of the best artisans in the world.





Fidello sectional sofa shown in Stylish thick leather.
H76-102 - W356 - D269 cm
H30-40 - W140 - D106"

Herman coffee table.
Herman accent.
Pumo craft items.
New Decò rug.
Fil Rouge sideboard.



designed by
Manzoni&Tapinassi

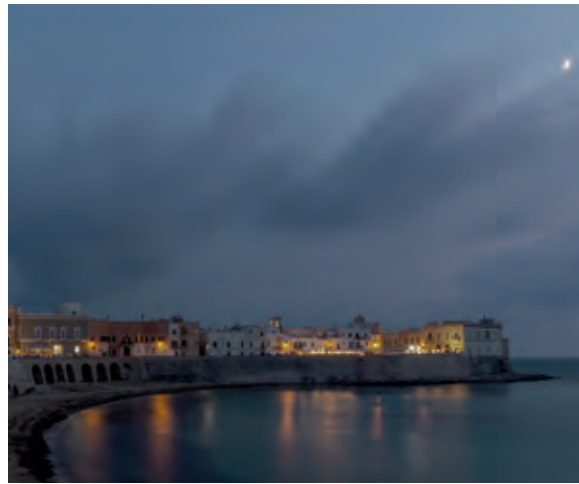

dorian

Time-defying design meets extreme modularity and extraordinary versatility - this was bound to become a perennial piece in our Natuzzi Italia collection. Dorian's appeal will never pall because its sleek silhouette and comfort-centric design will stay unchanged thanks to the premium-quality padding.

Refined raw-cut edges bring to the fore the beauty of the coverings, such as the premier-quality Cassidy leather (thickened and natural) and the innovative Manopesca (peachskin texture) fabric.



Dorian sectional with end unit shown in Stylish thick leather.
H79 - W318 - D278 cm
H31 - W125 - D109"
Herman coffee table and pouf.
Pumo craft item.
Dami floor lamp.
Sophia B rug.

It has been meticulously finished down to the tiniest detail and each single seat unit can also be used as a standalone piece.



herman

designed by
Manzoni&Tapinassi

Restrained chic and compelling design flair - the **Herman** footstool is as unforgettable as a piece of adventure fiction.

Herman pouf shown in Premium fabric with a pewter metal finish.



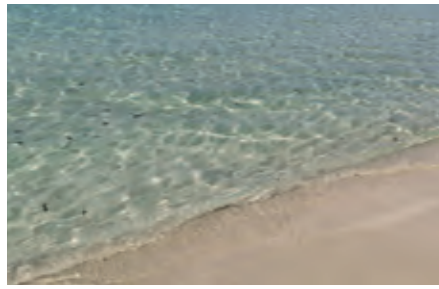

designed by
Nika Zupanc

deep

Deep is closely linked to water and its fluid nature, with voluptuous lines that are reminiscent of the ebb and flow of the tide. Its seats come in a variety of different shapes and depths, lending themselves to countless combinations and infinite compositions with the other elements.



Deep sectional shown in Essential leather.
H79 - W346 - D282 cm
H31 - W136 - D111"
Adore swivel armchair.
Voyage coffee table.

Pumo craft item.
Vortex rug.
Voyage dining table.
Voyage chairs.
Joy pendant lamp.

The back is a triumph of circularity and rotundity, immediately conveying a sense of visual comfort.



Nika Zupanc redefines the world of interior design in her own personal, poetic and distinctly feminine fashion. Her objects defy rationality and create an intimate, emotional and intuitive dimension. Her visual language aims to “communicate things that cannot be said”, pushing back the frontiers of materials and possibilities to breathe life into refined pieces that have been meticulously crafted and curated. This is why Elle USA used the words “punk elegance” to describe her work. Her installations are on display at the most important art galleries in the world and are often the product of partnerships and special projects, like that with the Rossana Orlandi Gallery of Milan. She takes an eclectic approach that bridges the gap between art and design and, over time, this has led her to take on interior-design projects that she follows from A to Z, curating them down to the tiniest detail with a sophisticated aesthetic packed with motifs and references that turn up everywhere in true Giò Ponti style. Her holistic mindset helped to bring about the encounter with Natuzzi, as it is in perfect keeping with the brand’s “total-harmony” philosophy. And so, a collection came into being that focuses on waves, their visual impact and the inner mood they create because each piece has been devised for life seen as an emotionally-charged experience and a dwelling for the soul. A collection you can find yourself in, lulled by the reassuring familiarity of the sea and the eternal beauty of Mediterranean nature - a source of shared inspiration for Natuzzi and Zupanc.

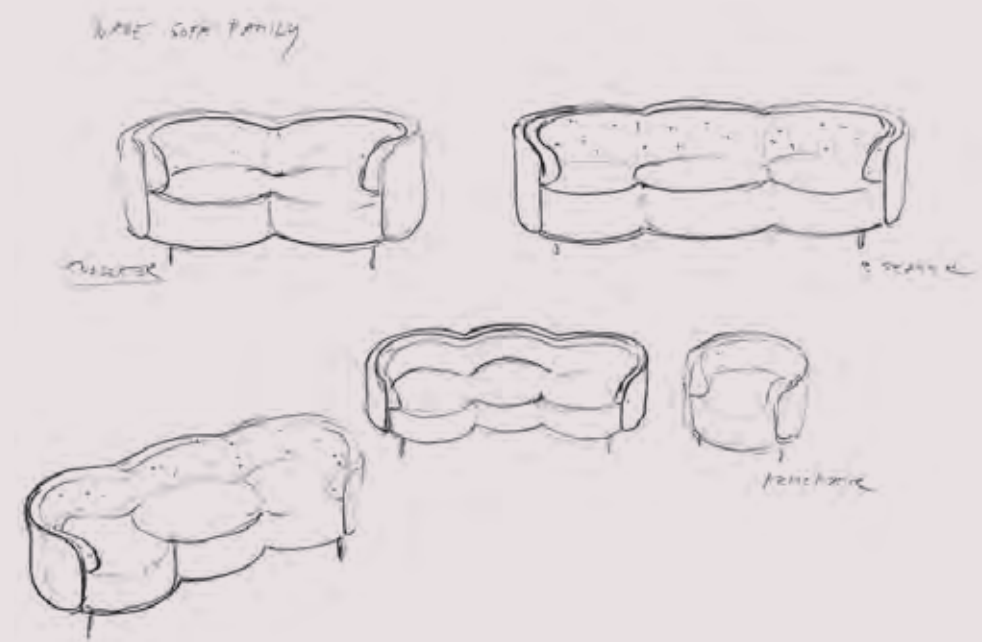

“The collection is here to embrace and protect you, to become your true home. Beneath the waves there is always an ocean of peace”.

adore



designed by
Nika Zupanc



The backrest is high and sumptuously soft and the seat turns on itself thanks to a conical swivel base with a tech-glam flourish. **Adore**, an iconic and sensual armchair.

Adore swivel armchair shown in Premium fabric with base in brushed metal with a light-gold finish.





vortex

designed by
Nika Zupanc

An optical effect brings to mind the shimmering surface of the sea. **Vortex** marks the line between interior décor and art.

Vortex rug shown in platinum version.

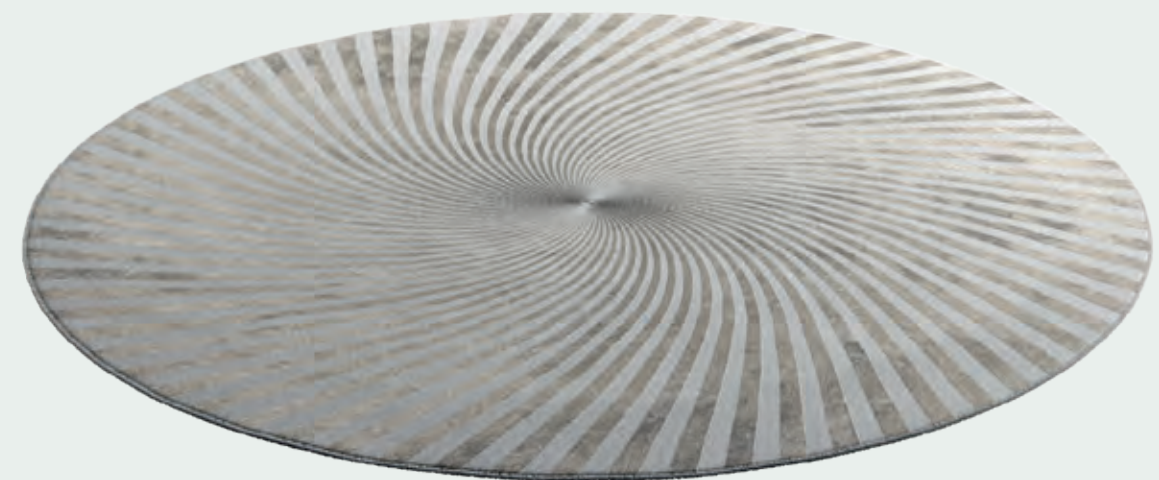

voyage

designed by
Nika Zupanc

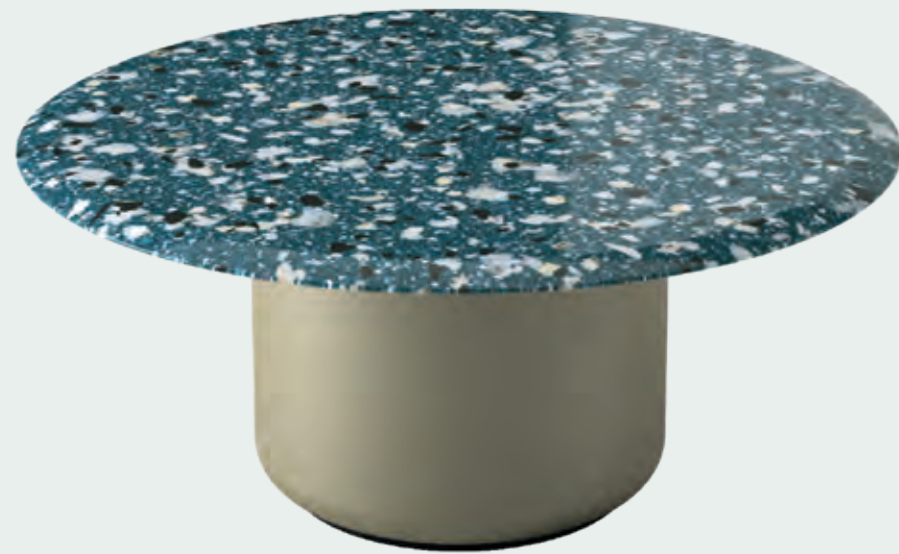

Voyage is halfway between a coffee table and a sinuous sculpture with its sleek silhouette and refined materials.

Voyage coffee table shown with central base with a light-gold matte satin finish and top in Stardust Terrazzo Stone.



wave

Wave three-seater sofa shown in Premium fabric.
H74 - W242 - D98 cm
H29 - W95 - D39"
Wave pouf and Voyage magazine rack.
Vortex rug.
Voyage dining table.
Voyage chairs.
Joy arch lamp.

Each detail adds vintage appeal, starting from the light-gold finish on the base.



wave and voyage

designed by
Nika Zupanc



The lofty allure of the **Wave** pouf and **Voyage** magazine rack - positioned next to the seat or integrated into the pouf to offer new furnishing solutions.

Wave pouf shown in Premium fabric and **Voyage** magazine rack in light-gold metal.



deep

Deep three-seater sofa
shown in Trendy fabric.
H71 - W305 - D131 cm
H28 - W120 - D52"
Deep dormeuse.
Joy floor lamp.
Tide bookcase.
Wave pouf and **Voyage**
magazine rack.
Mermaid mirror.
Sailors mirror.

Deep is a chaise longue
that embraces and
protects you while you
contemplate the passage
of time in peace and quiet.



tide

designed by
Nika Zupanc



Tide by Nika Zupanc.
A modular bookcase
with countless different
layout options and a
sinuous sculpture that is
reminiscent of the ebb
and flow of the tides.

Tide bookcase shown
in light-gold metal.





joy



designed by
Nika Zupanc

Joy fills your home with the soft glow of happy evenings spent on the beach.

Joy floor lamp shown with a light-gold finish, white matte ceramic details and an iridescent glass sphere.

mermaid and sailors

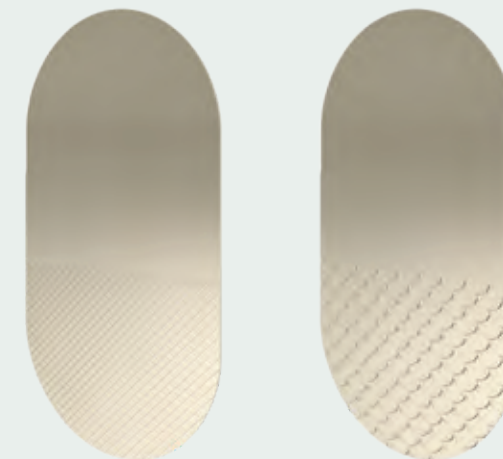

designed by
Nika Zupanc

Bronze-hued mirror surface, "scale" embellishments and a glamorous streak. The irresistible allure of **Mermaid**.

Mermaid and **Sailors** mirrors - bronze mirror.

designed by
Maurizio Manzoni



leaf

With its pristine-looking design and clean lines, Leaf is a celebration of iconic simplicity. Its versatility is enhanced by the detachable backrest cushions - for a comfortable aesthetic that lends itself to endless rearrangements. Abundant proportions and exclusive padding deliver unsurpassed levels of comfort.



The base in solid wood set on metal feet imbues this sofa with a powerful personality.

Leaf two-seater sofa shown in Essential leather.
H82 - W189 - D104 cm
H32 - W74 - D41"
Leaf sectional with end unit shown in Performance fabric.
H82 - W265 - D268 cm
H32 - W104 - D106"
Estro coffee table.
Ding Dong table lamp.
Decorative cushions.
Trullini aromatic candle.
Pumo craft item.



ding dong



designed by
Marcel Wanders studio

The delicacy of a bluebell upholstered in premium Natuzzi leather. Marcel Wander's **Ding Dong** table lamp.

Ding Dong table lamp version with white leather lampshade.





positano

With its generously rugged coastline gently sloping down to the waters' edge, Positano has inspired a sumptuously comfortable sofa. Maurizio Manzoni pays homage to the stylishness and eternal harmony of the Mediterranean refreshed with contemporary flair.

designed by
Maurizio Manzoni

The base in solid smoked oak reveals exquisite detailing in brushed brass.



Positano three-seater sofa shown in Trendy fabric.
H74 - W284 - D94 cm
H29 - W112 - D37"
Clemmie armchair.
Pumo craft item.
Colosseo floor lamp.
Seti rug.
Decorative cushions.



clemmie

designed by
Maurizio Manzoni



Welcoming yet restrained at the same time, **Clemmie** reworks the classic allure of the bergère armchair loaded with British stylishness.

Clemmie armchair shown in Essential leather with black chrome feet.



designed by
Mauro Lipparini

The base has been made from solid wood and metal, design details which make this sofa shine in every setting.

cava

With their vivid colours and unique ecosystem, the Bauxite caves are one of the great natural spectacles of Apulia and a source of inspiration for a collection which boasts an extremely visually striking system of modular sectional seats. A system which hinges on the constant aesthetic and functional transformations of its various parts.



Cava three-seater sofa in Trendy fabric.
H82 - W272 - D120 cm
H32 - W107 - D47"
Cava coffee tables.
Urchin vases.
Sophia B rug.
Aromatic candles.
Decorative cushions.



Conversation, companionship and rest with an electric sliding mechanism which allows you to move the backrest to and fro every time based on your specific needs.





With the flick of a wrist, the flip mechanism tilts the backrest, changing it from a vertical to a horizontal position



At the left, with a smoky glass finish.

The **Cava** coffee tables in clear, smoky and bronze glass create extremely refined optical effects.



designed by
Marcantonio

infinito

the poetry
of design

Infinito came into being thanks to the idea of cross-pollination and to an almost impossible challenge - taking the core aesthetic of one of the most powerful symbols for the human race and turning it into an object that has a strong symbolic value for Natuzzi - the sofa.



“It is necessary to steer new courses in the design world and seek new directions.”

With Natuzzi, this is what we have done. We put the focus on poetry for our project, turning infinity – a symbol packed with meaning – into a fascinating three-dimensional shape, a sort of sculpture created to help you relax, feel good, feast your eyes and enjoy good company. A sofa for meditating and opening up to inspiration.”



Infinito sofa shown in Premium fabric.
H85 - W300 - D242 cm
H33 - W118 - D95”
Colosseo arch lamp version shown in black chrome.





Marcantonio's research constantly blurs the boundaries between art and design. His personality and work are both a fusion of a love for art and one-of-a-kind pieces; his design objects are meant to be part of an everyday household and their dual nature is bound by his utterly free creative thinking. With a strong sense of humour, a love of nature and his own personal vision of contemporary design, he has produced pieces of work that have already become modern icons. His vision and poetic approach are perfectly summed up by the words: "Design teaches us to draw, but it is from art that we learn how to have ideas. We are crammed with shapes in the design world, and, I think that either we move towards applied design technology, which will always make sense, but that is not my field, or we move towards poetry." He has definitely chosen the latter pathway and he draws inspiration from anti-academic and visionary figures like Ingo Maurer and Gaetano Pesce. Marcantonio sees in them the concept of "impure", crossed-fertilised and playful creativity which ensues from the constant intermingling of the most varied sectors, from pop-art culture to storytales and from primitive art to comic strips, where the differences have their own intrinsic worth and are in contrast with the concept of design purity. This same intrinsic worth has always underpinned Natuzzi's design vision. This is why (for the new Circle of Harmony collection for which design blends are a cornerstone) Pasquale Junior Natuzzi "challenged" Marcantonio and his creative mind for this co-venture with the brand, involving him in a project which is, on the one hand, almost an impossible feat and, on the other, the best way to bring out that marvellous inner world which transpires from each artist/designer's work, imbuing it with an unmistakable unique feel.



"We have transformed the infinity symbol into a curvy sculpture which slides upon itself and becomes a restful sofa".

designed by
Manzoni&Tapinassi

tempo

Tempo's volumes and pared-back silhouette express a sophisticated sense of balance, making it the perfect place to experience harmony - pampered by the soft padding in memory foam and goose down, and lulled by the sweet embrace of a design that seems to put time on hold.

The feet have a special finish in dark-grey metal. Because harmony is also hidden in the details.



Tempo sectional
with end unit shown
in Premium fabric.
H77 - W320 - D229 cm
H30 - W126 - D90"
Tempo coffee table.
Pumo craft item.
Kendo mirror.
Seti rug.





phantom

designed by
Mauro Lipparini

The solidity of wood meets the impalpable elegance of glass. The **Phantom** writing desk.

Phantom desk shown in smoked oak with extra-clear glass leg.



hedi

designed by
Natuzzi Design Center



Its superb workmanship enhances its versatility. Its minimalist design makes it a masterpiece in its own right. **Hedi**, a sitting ovation.

Hedi chair shown entirely covered in Essential fabric.





tempo

designed by
Manzoni&Tapinassi



Time is on my side, as the song goes. Just like the **Tempo** coffee table, which is the perfect complement to any sofa.

Tempo coffee table shown with anthracite frame and lilac marble top.

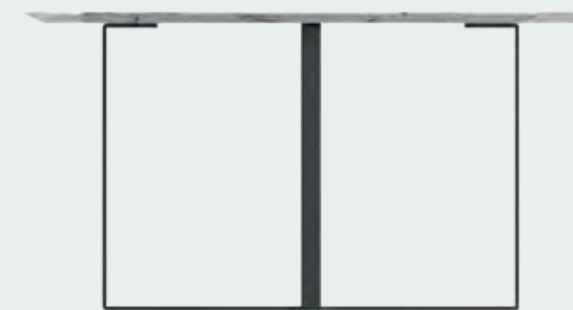



designed by
Mauro Lipparini

colosseo

A monument to versatility. The seats have even been designed to include storage units which serve as an armrest or a table top, giving rise to a new living-area concept where flexibility merges with the innovative comfort levels of our Triple-Motion function.

Colosseo two-seater shown in Essential leather with high wooden table top.
H75-98 - W291 - D109 cm
H30-39 - W115 - D43"
Colosseo table lamp.
Affresco rug.





colosseo



Colosseo three-seater sofa shown in Stylish leather with low wooden table top and wood panel.
H75-98 - W359 - D109 cm
H30-39 - W102 - D43"
Blossom armchair.
Fil Rouge coffee table.
Luce rug.
Trulli decorative bowl/plate.
Silo vases.



The vast range of solutions also includes free-standing panelling so you can partition off areas in your home or create private intimate corners.



The backrest, footrest and headrest can all be adjusted via the Triple-Motion mechanisms.



colosseo

designed by
Mauro Lipparini

Colosseo table lamp
version shown
with a champagne.

A metal cylinder
that expresses linear
simplicity. **Colosseo**
shines its light, even
when it is off.



designed by
Maurizio Manzoni



oblò

Oblò is the warm generous embrace of a welcoming home. The metal structure girds it - like a belt around a lithe body - bringing to the fore the elegance of its sleek silhouette. In addition, the tubular metal structure acts as a foot, giving the sofa an airy streamlined look.





With immense formal purity, the tubular structure encircles the backrest and armrests, extending to the feet as well.





Oblò sectional with end unit shown in Performance fabric.
H65 - W307 - D225 cm
H26 - W121 - D89"
Pumo craft item.
Orfeo cabinet.
Seti rug.

designed by
Enrique Marti

selva

A modular living system which bridges the gap between two different sources of inspiration - a futuristic aesthetic and Art Nouveau. The former gives it a distinctive geometric constructivist design which is counterpointed by the sensual generous volumes associated with Art Nouveau, producing a sensation of elegance, comfort and luxury.

The large bolster-shaped armrest is a style statement and a half.



Selva sectional with end unit shown in Stylish leather.
H73 - W325 - D267 cm
H29 - W128 - D105"
Pumo craft item.
Orfeo cabinet.
Halo table lamp.
Itria chair.
Seti rug.
Kendo mirror.

The coffee table beneath the armrest - one detail of a completely customisable project.

The refined "capped" feet in brushed brass.





itria

designed by
Enrique Marti



The comfort-centric design of Itria is a testament to the extraordinary beauty of Apulia, the **Itria** Valley and its splendid landscape.

Itria chair shown in burnished black with rings and tips in brushed brass.

halo

designed by
Massimiliano Raggi



A metal strip that encloses the light yet unleashes it at the same time. The illuminated design of the **Halo** light.

Halo table lamp version shown with external frame in burnished nickel and interior in champagne.



designed by
Enrique Marti



stan

With its endless number of hidden functions, Stan is the epitome of compact versatility. The size of the seat can be adapted to customer requirements and the headrests can be moved electrically up and down and forwards until you find the right position.

With the performance fabrics, elegance and practicality go hand in hand.





Stan chaise sofa shown in Performance fabric.
H87 - W293 - D160 cm
H34 - W115 - D63"
Stan three-seater sofa shown in Essential leather.
H87 - W206 - D97cm
H34 - W81- D28"
Pumo craft item.



Headrest and footrest
can be adjusted
separately for
individualised comfort.



Watch Stan
sofa in motion



The incredibly versatile design of the **Stan** sofa allows for personalisation so you can achieve a result that suits your style, space and comfort requirements down to the ground.

Here are some suggested arrangements.



Armchair
H87 - W98 - D97 cm
H35 - W39 - D38"



Three-seater sofa
H87 - W206 - D97 cm
H35 - W81 - D38"



Chaise sofa
H87 - W293 - D160 cm
H35 - W115 - D63"



Sectional
H87 - W293 - D206 cm
H35 - W115 - D81"



Sectional with chaise
H87 - W292 - D378 cm
H35 - W115 - D149"

designed by
Natuzzi Design Center

king

King celebrates an encounter between the sovereign of sofas (a symbol of exquisite artistry) and the best artisans in the world (unrivalled masters of leather, a material which has always been a jewel in Natuzzi's crown) with a lofty sofa whose sumptuous diamond tufting brings all its soft beauty to the fore.

The buttons are arranged into a square or diamond pattern, known as tufting. Button tufting requires an infinite amount of artisanal skill.





King three-seater sofa shown in Prestige leather.
H72 - W228 - D102 cm
H28 - W90 - D40"
Orfeo coffee table.
Urchin vase.
Orfeo cabinet.
Pumo craft item.
Halo floor lamp.

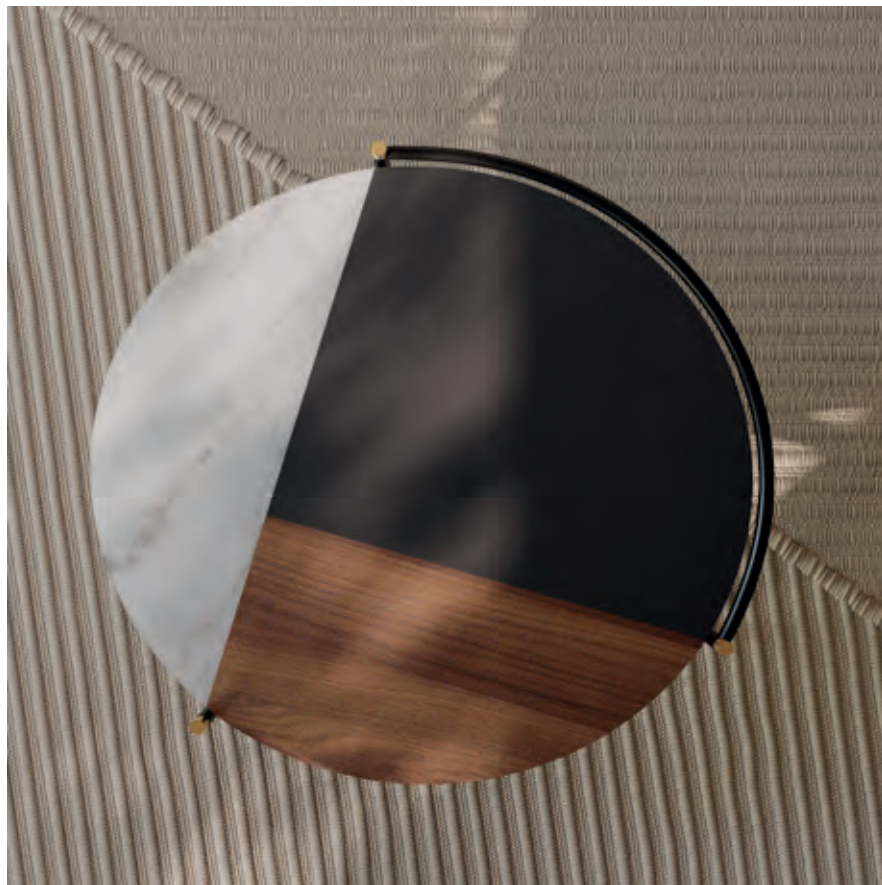

orfeo

designed by
Manzoni&Tapinassi

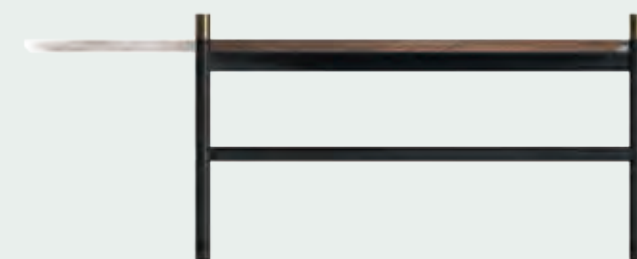

Superlative Italian craftsmanship and matchless style. The Orfeo coffee tables - get ready to be dazzled.

Orfeo coffee table shown in a mixture of materials for the top (matte lacquer anthracite - walnut wood and calacatta marble) with a metal structure in an anthracite-brass colour scheme.

orfeo

designed by
Manzoni&Tapinassi



Concentric circles, as if caused by a drop in a pool of water. Which Narcissus, enamoured of his own reflection, dived into.

Orfeo mirror shown with a black burnished finish.





marlene

designed by
Paola Navone



With her artistic flair, Paola Navone puts a new spin on the nineteenth-century bergère. Marlene - timeless comfort and immense visual lightness.

Marlene armchair shown in Premium fabric with wengé wooden feet.



new classic

New Classic, Fabio Novembre's reworking of the classic Chesterfield sofa has been given a contemporary urban feel and carefully designed with a harmonious blending of round and square shapes and volumes. A piece that instantly brings to mind visions of Apulia with its unforgettable atmosphere and timeless harmoniousness.

designed by
Fabio Novembre

Allow it to take centre stage and play a starring role in your living area. The back looks so good that it would be a shame to hide it.



New Classic three-seater sofa in a mixture of Stylish leather and Premium fabric. H77 - W322 - D108 cm
H30 - W127 - D43"

Orfeo coffee table.
Pumo craft item.
Amalia sofa.
Kendo table lamp.
Sophia B rug.





Side units fitted with full-length feet in tubular metal.



Fabio Novembre has been a leading light in the international design industry for over twenty years due to the visual power and iconic nature of his style. Marked by a highly recognisable visionary approach, his work has received a series of accolades and mentions in publications over the years. He has been scientific director of the Domus Academy and served on the scientific committee of the Design Museum at the Milan Triennale since 2019. Novembre and Natuzzi not only share a bond with Apulia which is a "motherland" and muse for both of them, but they also have a common passion for narration. This is what triggered their first key project together called *Intro* which was a 2016 Triennale installation put on display inside the "Stanze- Altre filosofie dell'abitare" ("Rooms - Novel living concepts") exhibition in partnership with the Salone del Mobile. A fascinating project based on a very lofty concept and a bearer of a sublime message, *Intro* brought to the fore the best of both Novembre and Natuzzi. By concentrating on the concept of the bedroom retraced to its most perfect ancestral roots, his mind settled on an egg represented by an oval-shaped alcove with an external mirrored-metal shell and a deep-red interior which looks almost like a womb; this alcove literally draws visitors in, isolating them in an otherworldly dimension before returning them to the world reborn with a keener sense of awareness. Crafted from materials customarily used for sofa manufacture and entirely hand-assembled by those who create sofas every day, *Intro* remains a one-of-a-kind piece of artistry and was a way to offer the international audience at the Triennale tangible proof of the love of craftsmanship that Natuzzi has always had. Four years down the line, Natuzzi and Novembre continue their remarkable teamwork, as is apparent from the strong bold aesthetic of the new collection and from the Circle of Harmony with a project that encapsulates all the extraordinary visual power of the designer from Lecce who many have likened to Fellini for his ability to generate images with an unmistakable trademark.

"Minimalist sensitivity and classic design. New Classic aims at getting these two philosophies closer to each other".



orfeo

designed by
Manzoni&Tapinassi

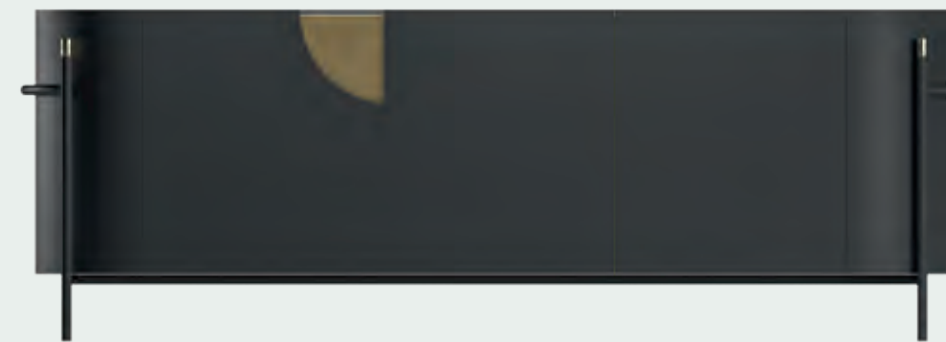

Superlative Italian craftsmanship and matchless design. The enchanting elegance of **Orfeo**.

Orfeo sideboard shown with a matte chocolate lacquered surface and a metal structure in chocolate-rose gold.

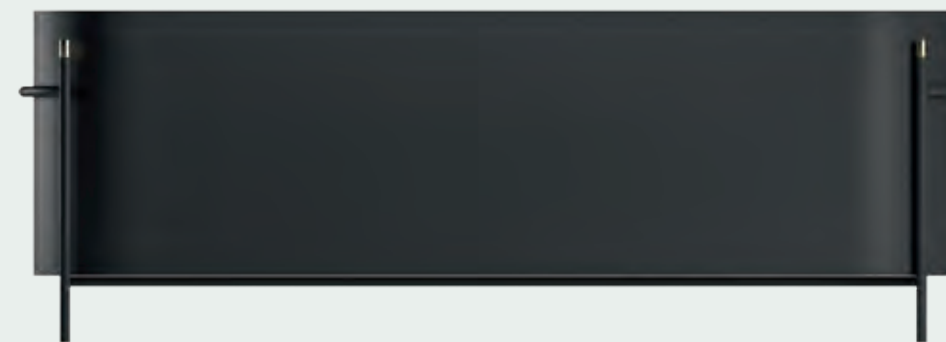

amalia

designed by
Bernhardt & Vella



Sharp geometrical shapes and sleek volumes for an oasis of relaxation and comfort. This is no mirage, it is the **Amalia** round sofa.

Amalia round sofa shown in Premium fabric and set on smoked oak feet.



Allow it to take centre stage and play a starring role in your living area. In any case, it would be a shame to conceal such a gorgeous part of this piece

designed by
Claudio Bellini

botanic

Taking its cues from forms found in Nature as its name suggests, Botanic puts a new spin on the stylish design of the '50s - those sleek lines and that cohesive approach which refashioned the aesthetics of home design - and turns it into a compact pared-back project.



Botanic three-seater sofa shown in Prestige leather. H80 - W192 - D82 cm
H31 - W76 - D32"
Botanic armchair.
Cava coffee table.
Pumo craft item.
Colossero floor lamp.
Sophia B rug.



botanic



designed by
Claudio Bellini



The **Botanic** armchair is a perfect match to the sofa - in terms of beauty, generosity and sheer comfort.

Botanic armchair shown in Premium fabric and set on matte black feet.



designed by
Natuzzi Design Center



philo

With its signature quilting (an instantly recognisable sign of fine Natuzzi craftsmanship) and unmistakable design, Philo immediately conveys a sense of hospitality and comfort. It is equipped with cutting-edge recliner functions and our innovative Zero Wall space-saving system.



Watch Philo
sofa in motion

Soft Touch: at the flick
of a wrist, the seat unit
turns into a chaise-longue
waiting for you to stretch
out and relax.





Philo three-seater sofa shown in Essential leather. H78-102 - W306 - D110 cm
H31-40 - W120 - D43"
Logos swivel armchair.
Icon coffee table.
Vico table lamp.
Sophia rug.

The incredibly versatile design of the **Philo** sofa allows for personalisation so you can achieve a result that suits your style, space and comfort requirements down to the ground.

Here are some suggested arrangements.



Two-seater sofa
H78/102 - W321 - D321 cm
H31/40 - W126 - D126"



Sectional
H78/102 - W321 - D321 cm
H31/40 - W126 - D126"



Three-seater sofa
H78/102 - W306 - D110 cm
H31/40 - W120 - D43"



Compact sectional
H78/102 - W321 - D227 cm
H31/40 - W126 - D89"



logos

designed by
Manzoni&Tapinassi



Sleek silhouette, swivel base, deep seat cushions and highly comfortable backrest. Its name is **Logos** but you can call it bed of roses.

Logos swivel armchair shown in Trendy fabric with a matte black metal base.



icon

designed by
Michele Menescardi



Exquisite materials and extreme formal purity: **icon**, the coffee table is served.

Icon coffee table shown with smoked oak/brass frame: as a central table with an orobico marble top and as an accent table with a smoked oak top.

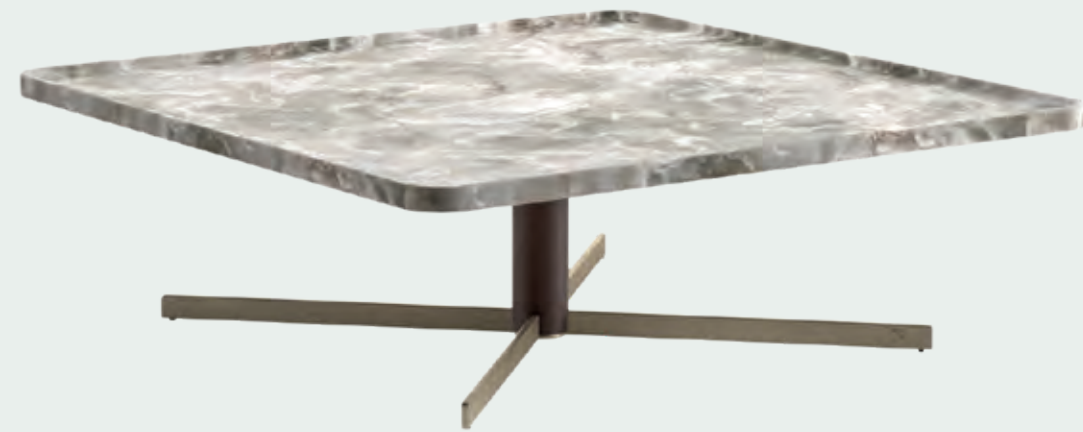

designed by
Paola Navone



argo

Drawing inspiration from Homer's Odyssey (Argos is Ulysses' dog and the first to recognise him when he comes back to Ithaca after more than twenty years), Paola Navone dreamt up a collection which lovingly awaits our return home ready to welcome us, soothe us and give us warmth.





Argo three-seater sofa shown in Stylish leather.
H76 - W236 - D109 cm
H30 - W93 - D43"
Argo three-seater sofa shown in Premium fabric.
H76 - W236- D109cm
H30 - W93- D43"
Argo reclining chaise-longue for sleeping.
Chocolat coffee table.
Pumo craft item.
Calcada rug.
Fil rouge bookcase.
Colosseo floor lamp.
Silo vases.
Trullini room fragrance.

Argo reclining chaise-longue for sleeping shown in Premium fabric.

The chaise-longue with a recliner mechanism has an ideal position for every occasion and for each single moment in time.

The decorative martingale at the back of the sofa makes it the ideal centrepiece for a room where it is bound to play a starring role during gatherings of family and friends.



Paola Navone It was in the late '70s that Paola Navone made a name for herself on the international landscape, being, as she was, as a key figure within the Alchimia group (the most avant-garde set on the Italian design scene) and working alongside names like Ettore Sottsass, Andrea Branzi and Alessandro Mendini. Very much a citizen of the world, she is insatiably curious about other cultures (especially Oriental ones) and looks to travelling as a means to fuel her imagination and find inspiration; travel is what gratifies her most, and, in addition to habitually crossing geographical borders, she also customarily pushes back frontiers in other areas. In the course of her extensive career, she has slipped effortlessly from one professional role to another (art director, designer, architect, essayist, interior designer, teacher and curator of exhibitions and events), displaying not only her aptitude for an extremely exciting eclecticism, but also the prolific nature of her work. All the colours and flavours (discovered, adored and experienced) of the Southern hemisphere emerge from her work, yet are tempered by the styles and shapes of a rich Western tradition. And it was her love for the traditional and classical forms of home furnishings that led to the first partnership with Natuzzi in 2010 when the *I Fondamentali* collection came into being; this was a set of armchairs and sofas which drew inspiration from historical drawings that we are all familiar with, but were refreshed with a modern spin. Forms known to us, but softened and redefined with small sophisticated details which turn them into timeless objects, blurring the line between past and future with a subtle tongue-in-cheek twist. This range became a Natuzzi Italia style icon and a permanent part of the collections. It is a prime example of timeless harmony - as is her new project which responds to Pasquale Junior Natuzzi's invitation to join the Circle of Harmony and create a collection which is a blend of unique designs and a tribute to Mediterranean lifestyle. A theme which she interpreted in her own supremely unique way, as you would expect from a designer who is quintessentially cosmopolitan and relentlessly seeks out new worlds as well as fresh materials, forms and structures.



“Travelling is my way of breathing, of looking at the world. As I travel I store colours, shapes, materials, sensations in my head”.



chocolat

designed by
Natuzzi Design Center



Unusual geometric shapes and exquisite materials – stone, glass or marble. The irresistible allure of the **Chocolat** coffee tables.

Chocolat coffee tables shown with a pewter frame. In this page with an Athens silver cream top. To the right, with a smoky glass top and a dark-grey back-lacquered surface.

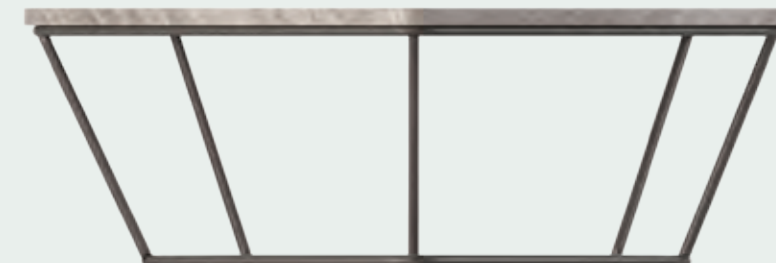

calcada

designed by
Sopa Studio

Superlative workmanship that is reminiscent of ancient floors - paved surfaces and mosaics. The **Calcada** rug.

Calcada rug shown in blue wool.

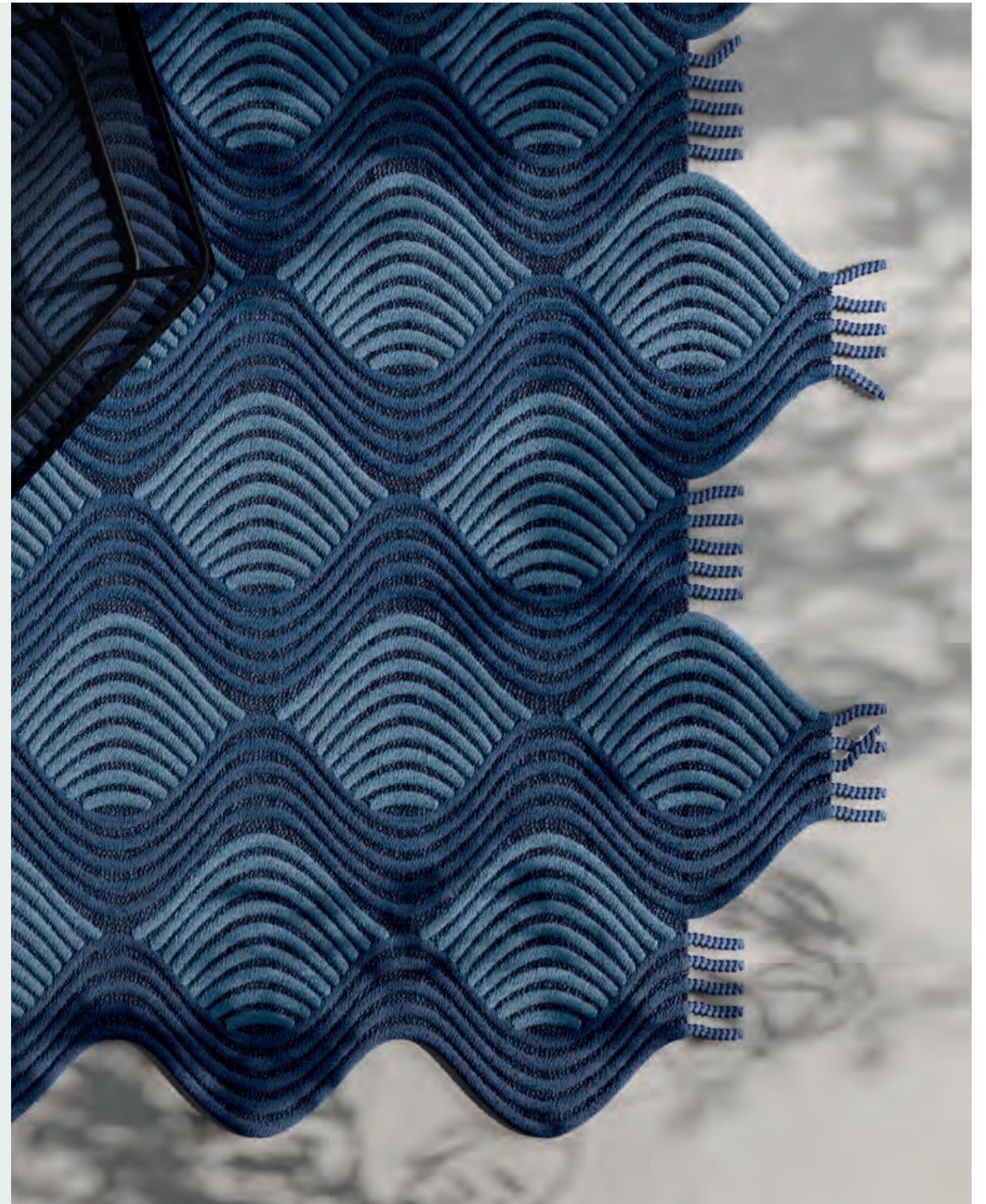
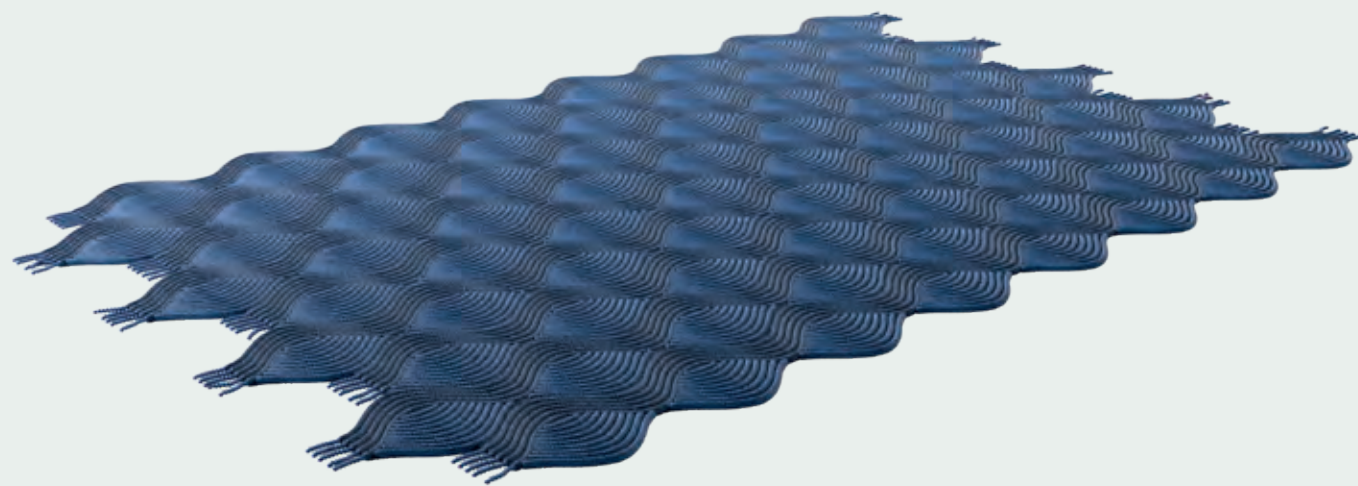

designed by
Claudio Bellini

don giovanni

Its sleek silhouette bespeaks all the appeal of comfort and the value of Italian design. The absence of cuts and seams on the seat cushions and backrest accentuates its pristine appearance which seduces like the discreet charm and low-key stylishness of a modern Don Giovanni.





Don Giovanni three-seater sofa shown in Trendy fabric.
H80 - W234 - D102 cm
H31 - W92 - D40"
Dolly armchair.
Affresco rug.
Room fragrance.

A touch of elegance is offered by the trim on the armrests and seat cushions which are also available with a contrasting colour.





dolly

designed by
Claudio Bellini



An astonishingly fresh design which achieves an unusual balance between comfort and style, and sumptuousness and airiness. The **Dolly** armchair.

Dolly armchair shown in Essential leather with glossy chromed feet.



designed by
Natuzzi Design Center

estro

Estro's design strikes a perfect balance between imagination and restraint, comfort and compactness. It boasts a pared-back contemporary silhouette, elegantly punctuated by slender feet on which the large comfortable seat unit rests.

The open base creates an aesthetically pleasing angle with the armrest.





Estro three-seater sofa shown in Smart fabric.
H81 - W198 - D94 cm
H32 - W78 - D37"
Dodi armchair.
Labirinto coffee table.
Bis pouf.



dodi

designed by
Natuzzi Design Center

A refined design, deep seat cushions and a highly comfortable backrest. **Dodi**, downsized downtime.

Dodi swivel armchair shown in Essential leather and Performance fabric with a black chrome base.



fly

A surprisingly sleek sofa with a streamlined silhouette, versatile design and an exclusive mechanism that allows you to adjust the depth of the seat cushion to your liking. A project that epitomises Natuzzi's concept of innovation - an ingenious idea that simplifies our lives.

designed by
Manzoni&Tapinassi



Fly chaise sofa shown
in Essential leather.
H77-90 - W293 - D155 cm
H30-35 - W115 - D61"
Cabaret coffee table.

Elsa floor lamp.
Sophia B rug.
Decorative cushion.



The depth of the seat cushion
can be widened or narrowed
so you can enjoy the utmost
customised comfort.





platea

designed by
Natuzzi Design Center



Platea. A design journey through time that finds its ideal destination in the swinging Sixties and offers time-defying comfort levels.

Platea armchair shown in Performance fabric with glazed nickel legs.



designed by
Natuzzi Design Center



borgnese

Sumptuously soft with polyurethane and shape-memory-foam padding, Borgnese delivers supreme comfort levels with its adjustable headrests. With an in-line or corner arrangement with or without a chaise-longue, its compact flair will always usher airiness and uncomplicated elegance into any setting.

Available with a base
in solid wood or metal.
Because perfection is
not a detail.





Borghese sectional with end unit shown in Essential leather.
H73-93 - W230- D294 cm
H29-37 - W91 - D116"
Chocolate coffee table.
Pumo craft item.
Decorative cushions.

The adjustable headrests offer ideal support, allowing you to relax, read or idly chat with your guests.



Watch Borghese sofa in motion





cassia

designed by
Mauro Lipparini



A design-forward and invitingly curvaceous shell. **Cassia** defines the new geometry of comfort.

Cassia armchair shown in Performance fabric with smoked oak feet.



designed by
Manzoni&Tapinassi

tratto

“Less is more” is the perfect way to describe Tratto and its aesthetic. Its compact silhouette and extremely simple lines are as easy on the eye as they are comfortable. Yet again, in true Natuzzi style, it is the details that make the difference - in this case, zigzag topstitching that lift this piece out of the ordinary.



The elegant zigzag topstitching is also available in a contrasting colour.



Tratto sectional with end unit shown in Performance fabric. (727)
H75 - W226- D207 cm
H30 - W89- D81"
Cabaret coffee table. (484, 767)
Trulli decorative bowl/plate. (832)
Sophia B rug. (812)

Galileo table lamp. (486, 815)



designed by
Manzoni&Tapinassi



jeremy

A happy marriage between design and architecture. The armrests and frame are intricately interlocked, and comfort levels are exceptional thanks to the mixture of polyurethane, shape-memory-foam and down padding. The neat feet give it a sense of order while also lightening and streamlining its silhouette.

The Jeremy armchair
creates an ideal
conversation area.



The base and armrest have been dovetailed to fit with the backrest. A single detail that embodies a relentless quest for quality.



Jeremy sectional with end unit shown in Performance fabric.
H80 - W266- D253 cm
H31 - W105- D100"

Dandy candle holder.
Colosseo floor lamp.
Sophia B rug.
Decorative cushions.

Cabaret coffee table.



colosseo

designed by
Mauro Lipparini



A metal cylinder that expresses linear simplicity. Colosseo shines its light, even when it is off.

Colosseo arch lamp version shown with a black chrome finish and white lampshade.



designed by
Natuzzi Design Center



duca

An ode to hi-tech lifestyle and multi-sensorial pleasure made up of design, comfort and music. Adjustable headrests and recliner mechanisms deliver outstanding comfort, while an exclusive Sound System built into the sofa (available upon request) provides a phenomenal listening experience.





Duca three-seater sofa in Essential leather.
H78-102 - W238- D108 cm
H31-40 - W94 D43"
Fil Rouge coffee table.
Fil rouge bookcase.
Sophia B rug.



Watch Duca sofa in motion

The exclusive Soft-Touch mechanism allows you to customise your experience and make it your own special haven of relaxation.

fil rouge

designed by
Mauro Lipparini

A variety of shapes, surfaces, volumes and materials, but only one **Fil Rouge** that always leads back to balance and harmony.

Fil Rouge coffee table shown in walnut with a burnished black metal frame and volakas marble top.

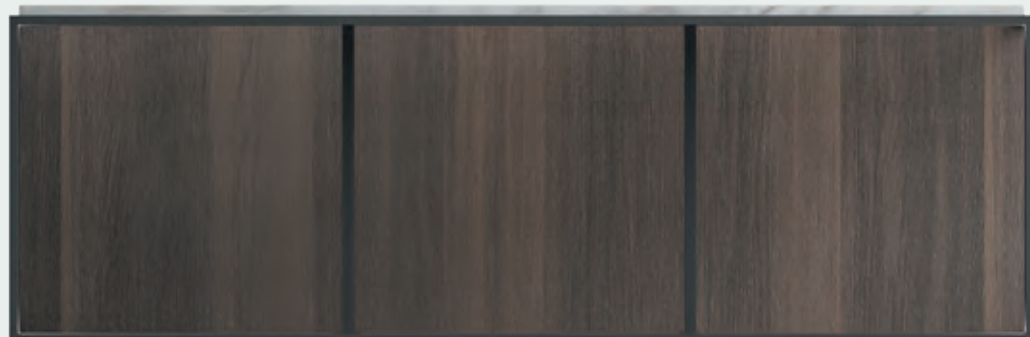

designed by
Natuzzi Design Center



balance

The perfect Balance between fine Italian craftsmanship and hi-tech comfort - adjustable headrests on each seat, integrated lower-back cushions, recliner functions and an exclusive Audio System (available upon request) with loudspeakers integrated into the sofa which can be activated via Bluetooth.





Balance sectional with end unit shown in Essential leather. H75/95 - W319 - D249 cm
H30/37 - W126 - 98"
Cava coffee table.
Ding Dong pendant lamp.
Pi Greco chairs.



The exclusive Soft-Touch mechanism allows you to customise your experience and make it your own special haven of relaxation.



Watch Balance sofa in motion

The incredibly versatile design of the **Balance** sofa allows for personalisation so you can achieve a result that suits your style, space and comfort requirements down to the ground.

Here are some suggested arrangements.



Armchair
H75/95 - W119 - D108 cm
H30/37 - W47 - D43"



Three-seater sofa
H75/95 - W 304 - D108 cm
H30/37 - W120 - D43"



Sectional
H75/95 - W319 - D235 cm
H30/37 - W126 - D 92"



Sectional with end unit
H75/95 - W319 - D249 cm
H30/37 - W126 - 98"



Sectional with chaise
H75/95 - W319 - D 403 cm
H30/37 - W126 - D 159"



cava

designed by
Mauro Lipparini

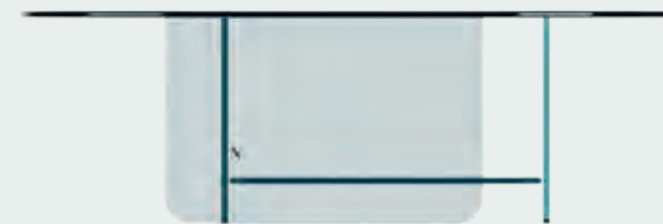

The **Cava** coffee tables in clear, smoky and bronze glass create extremely refined optical effects.

Cava coffee table shown in a central version with transparent glass and heavenly-coloured base; accent table versions with a coffee-brown metal frame and a top in heavenly-coloured glass.

designed by
Natuzzi Design Center

plaza

A tribute to comfort and luxury and to the lounges and halls of large New York hotels epitomised by the Plaza. A bold design with an original-looking armrest and an attractively angled seat which not only brings out this sofa's strong character but also contributes to its streamlined beauty.



Plaza sectional shown
in Essential leather.
H82 - W311 - D311 cm
H32 - W122 - 122"
Labirinto coffee table.

Silence rug.
Pumo craft item.
Decorative cushions.



labirinto

designed by
Claudio Bellini



Labirinto. Glass in a variety of tones creates an intricate interplay of hues and geometric shapes. Enraptured, the eye is lost in its beauty.

Labirinto coffee tables shown in a square version in smoky glass and in a rectangular version in transparent glass.





silence

The effect of raindrops on a windowpane.
The **Silence** rug will have you lost for words.

Silence rug shown in grey wool.

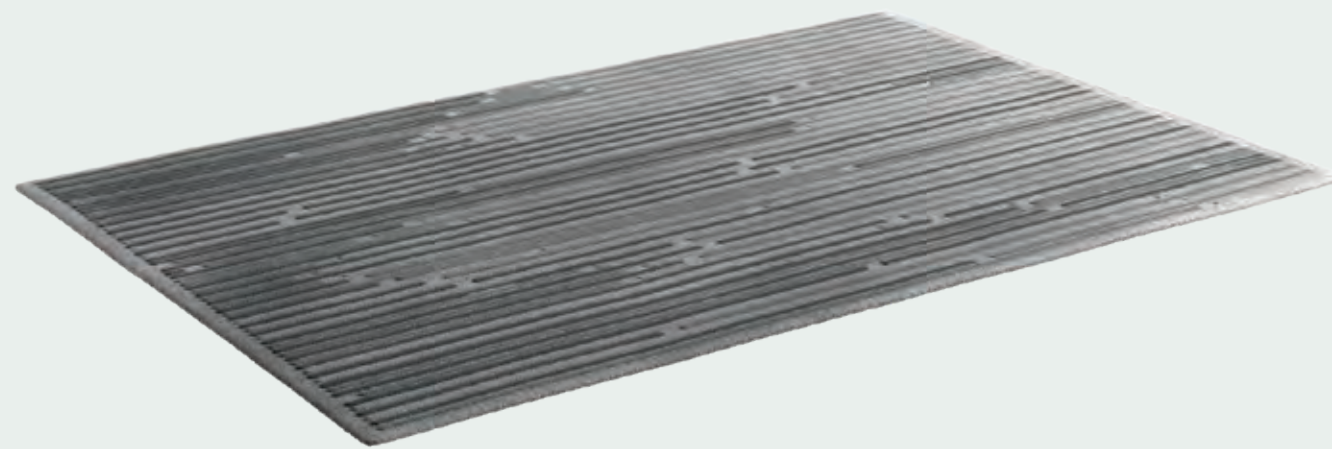

designed by
Manzoni&Tapinassi

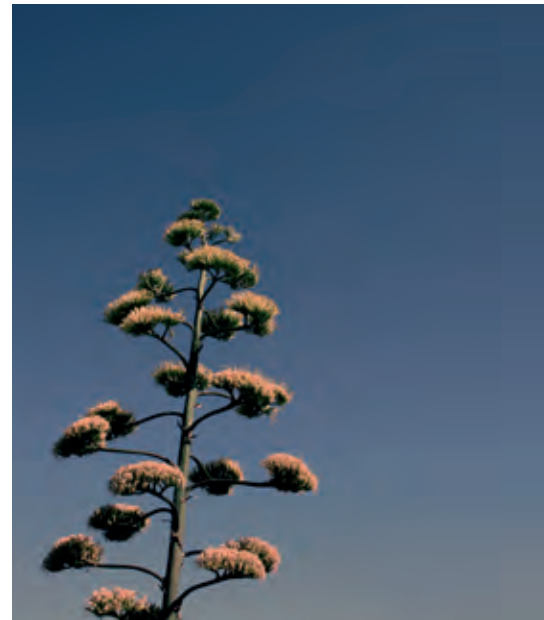

opus

A versatile design project that allows users to “build” their own sofa - choosing from the vast array of combinations available - and to elevate any atmosphere with its powerful personality. The open base brings to the fore the unusual beauty of its sleek silhouette, streamlined shape and soothing horizontal lines.

The table top at the side provides extra space for objects and reading material.



Opus sofa with end unit
shown in Premium fabric.
H85 - W279 - D103 cm
H33 - W110 - 41"
Luna armchair.
Herman coffee table and pouf.
Globes rug.





luna

designed by
Claudio Bellini



The **Luna** armchair will brighten any room with its sumptuous silhouette and striking design. Also available with a swivel base.

Luna armchair shown in Premium fabric and set on oak coffee-brown feet.

herman

designed by
Manzoni&Tapinassi



A groundbreaking project in terms of design and comfort. The **Herman** coffee table.

Herman coffee table shown with a pewter frame and a smoked oak wood or invisible grey marble top; the pouf comes in velvet with a pewter frame.



designed by
Natuzzi Design Center

Precious handcrafted
details give character and
a sense of exclusivity.

galaxy

A galaxy of comfort and innovation with a depth of just one metre which makes this sofa ideal for living areas of an “earthly” size. Galaxy offers the utmost in versatility, modularity and next-generation space-saving features.

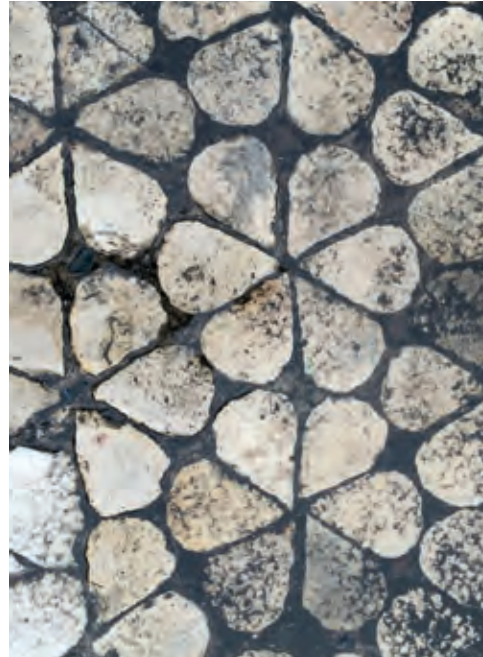

Headrest and footrest
can be activated and
adjusted separately.



Watch Galaxy
sofa in motion



Galaxy Galaxy chaise sofa
shown in Essential leather.
H77 - W286 - D159 cm
H30 - W113 - D63"
Jade rug.

Fortuna sideboard.
New saturno dining table.
Sovrana chair.
Circle pendant lamp.
Pumo craft item.

The incredibly versatile design of the **Galaxy** sofa allows for personalisation so you can achieve a result that suits your style, space and comfort requirements down to the ground.

Here are some suggested arrangements.



Two-seater sofa
H85 - W202 - D100 cm
H33 - W79 - D39"



Three-seater sofa
H77 - W289 - D168 cm
H30 - W114 - D66"



Chaise sofa
H77 - W286 - D159 cm
H30 - W113 - D63"



Sectional
H77 - W296 - D296 cm
H30 - W117 - D117"



Sectional with chaise-longue
H77 - W296 - D383 cm
H30 - W117 - D151"

designed by
Natuzzi Design Center



VOLO

Perfectly proportioned with a compact shape and highly versatile, Volo boasts extreme comfort with a next-generation soft-touch mechanism. Artisanal stitched detailing (available in a contrasting hue as well) showcases Natuzzi's unrivalled experience in leather processing.



Watch Volo
sofa in motion

A flick of the wrist and the recliner function opens backrest, seat and footrest at the same time.



Volo sectional with
end unit shown
in Essential leather.
H73-97 - W279 - D241 cm
H29-38 - W110 - D95"
Talia armchair.
Saturday coffee table.
Trullini room fragrances.



talia

designed by
Natuzzi Design Center



Tapering metal feet and light lines. The **Talia** armchair is a throwback to the fabulous Fifties.

Talia armchair shown in Performance fabric with black chrome feet.





saturday

designed by
Natuzzi Design Center



Saturday, the versatile coffee table with a gorgeously graphic aesthetic.



Saturday coffee tables shown in a central and accent version with a black burnished frame and a smoked-oak or resin-concrete top.

rose



designed by
Natuzzi Design Center

Floral forms turning into
enveloping modern lines.
The **Rose** armchair.

Rose chair shown in
Premium fabric.

omega



designed by
Manzoni&Tapinassi

Omega, the last letter in
the Greek alphabet and the
last word in design.

Omega desk shown with a
matte anthracite frame and
dark emperador or waxed
calacatta gold marble.



designed by
Natuzzi Design Center



diesis

Diesis is a seating system which stands out for its compact silhouette and supreme comfort levels. The Soft-Touch mechanism turns any seating composition into a customised lounging experience. What is more, it doubles up as a bed with an innovative antibacterial non-allergenic Greenplus mattress.



Watch Diesis
sofa in motion

Recliner mechanisms to
open the seat, backrest and
footrest at the same time.



The headrest can be adjusted separately for individualised comfort.



Diesis sectional with end unit shown in Essential leather.
H77/98 - W213 - D257 cm
H30/39 - W84 - D101"
Logos armchair.
Icon coffee table.
Silence rug.



The incredibly versatile design of the **Diesis** sofa allows for personalisation so you can achieve a result that suits your style, space and comfort requirements down to the ground.

Here are some suggested arrangements.



Sectional with end unit
H77/98 - W213 - D257 cm
H30/39 - W84 - D101"



Three-seater sofa
H77/98 - W212 - D105 cm
H30/39 - W83 - D41"



Sectional
H77/98 - W304 - D219 cm
H30/39 - W120 - D86"



Chaise sofa
H77/98 - W244 - D168 cm
H30/39 - W96 - D66"



Sectional with chaise-longue
H77/98 - W338 - D219 cm
H30/39 - W133 - D86"

designed by
Natuzzi Design Center



brio

Brio, a musical inspiration that conjures up not only liveliness and extreme versatility, but also a refined dimension with an almost Mozartian atmosphere. The Soft-Touch mechanism and the audio system with loudspeakers (which are Bluetooth-activated) built into the sofa make it suitable for an uncompromisingly modern lifestyle.



Brio chaise sofa shown
in Essential leather.
H72/99 - W263 - D163 cm
H28/39 - W104 - D64"
Re-vive Quilted.
Pumo craft item.
Decorative cushions.
Silo vases.



Watch Brio
sofa in motion

designed by
Natuzzi Design Center

leuca

A place of encounter is the leitmotif that defines this project - first of all, a meeting between backrest and seat cushion which cleverly converge in an unusual fashion. After this comes a series of harmonious geometrical shapes which unite and give way to the next one, creating an inviting sense of compactness.



The adjoining of the frame and the armrest - a perfect fusion of design proficiency and artisanal artistry.



Leuca three-seater sofa in Trendy fabric.
H85 - W207 - D94 cm
H33 - W81 - D37"
Platea armchair.
Mercurio coffee table.
Vico table lamp.



mercurio

designed by
Natuzzi Design Center



The minimalist purity of a shape in hot-forged curved glass. **Mercurio** (the Italian word for Mercury) is a bearer of modern messages.

Mercurio coffee table shown in smoky glass.

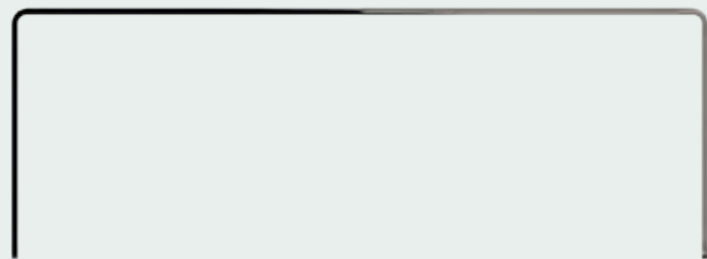

designed by
Michele Menescardi



icon

Icon's sumptuously soft silhouette and rounded appearance give it that immense visual comfort that made Natuzzi sofas so unmistakable in the '80s and '90s. A highly flexible system which allows you to create lounging areas that are in keeping with space requirements and your own personal taste.



Icon three seater sofa
shown in Essential leather.
H78 - W232 - D106 cm
H31 - W81 - D42"
Icon sectional with end
unit in Performance fabric.
H78 - W307 - D277 cm
H31 - W121 - D109"

Icon coffee table.
Urchin vases.
Colosseo floor lamp.
Phantom sideboard.
Affresco rug.
Decorative cushion.





The decorative trim along the edge of each seat unit. Natuzzi's superiority emerges from a detail.

The seat units are covered on all sides so each one can be used separately as well.

designed by
Claudio Bellini



seagull

With its distinctive folded-over armrests ready to spread out like a pair of wings, Seagull is a tribute to the visual comfort that marked Natuzzi style in the '80s and '90s. Its soft silhouette instantly ushers in a sense of comfort which is further enhanced by the recliner mechanisms and adjustable headrests.

The slender delicately folded armrests contribute to its unmistakable original aesthetic.





Seagull Seagull sectional shown in Performance fabric. H75/100 - W321 - D228 cm
H30/39 - W126 - D90"
Aura armchair.
Cava coffee table.
Pumo craft item.
Faces mug.

Personalise quality
downtime by simply
pushing a button.
The magic of the
recliner mechanism.





aura

designed by
Claudio Bellini



A breezy feel and an invitingly large seat cushion. The **Aura** of modernity, interpreted by Claudio Bellini.

Aura armchair shown in Essential leather and set on oak coffee-brown feet.



pi greco

designed by
Manzoni&Tapinassi



Pi Greco, the chair for which comfort is a mathematical constant.

Pi greco chair shown covered entirely in Essential leather.



designed by
Mauro Lipparini



levante

With a compact silhouette and an open base, Levante emanates a powerful personality. Vertical topstitching runs parallel to the armrests which stop slightly short of the edge, bringing to fore their design. A detail that counterpoints the plushness of the inviting cushion seats.



Levante three-seater sofa shown in Essential leather.
H76 - W224 - D87 cm
H30 - W88 - D34"
Cabaret coffee table.
Pumo craft item.
Galileo table lamp.
Sophia B rug.
Decorative cushions.



The slender feet increase the sense of airiness, geometrical sleekness and stability.





cabaret

designed by
Natuzzi Design Center



With their wide range of shapes, sizes and materials, the **Cabaret** coffee table will fit perfectly into any environment.

Cabaret coffee tables shown with a glossy frame and - to the left - with a white Carrara-marble top and - to the right - with a frosted white top.

galileo

designed by
Michele Menescardi



Like planets, two reflectors revolve around a light source, creating an attractive interplay of light and shadow.
Galileo table lamp.

Galileo table lamp version shown with a volakas marble base and blue lampshade.



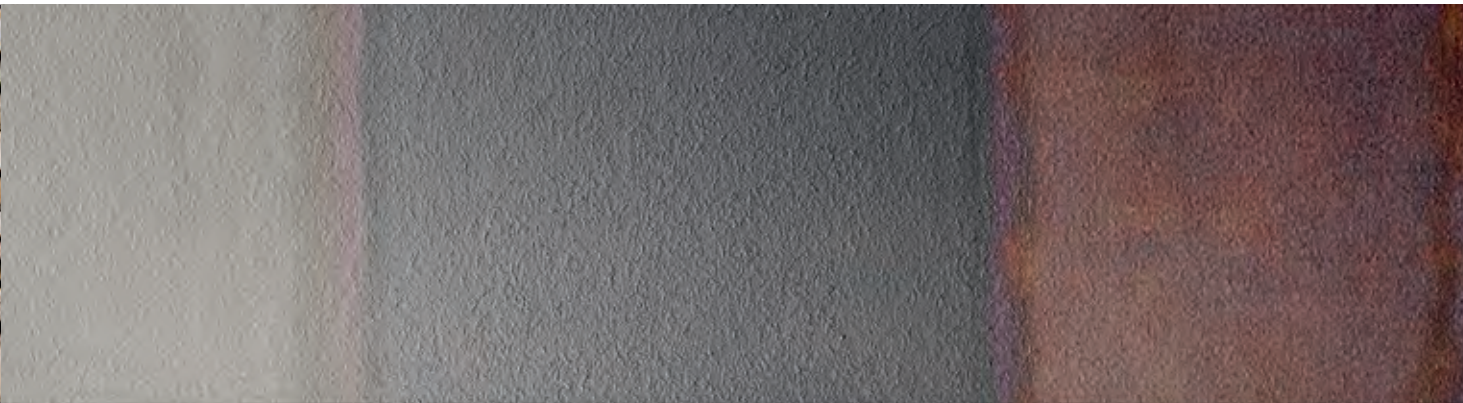

designed by
Natuzzi Design Center

preludio

With its invitingly generous silhouette, the premier mixture of paddings in polyurethane and Shape-Memory Foam and a personalisation system for each single seat unit, this sofa truly is a prelude to total relaxation. The elegant open base brings to the fore the beauty of its minimalist ergonomic design. (720)



Preludio sectional with
end unit in Stylish leather.
H69/90 - W307 - D234 cm
H27/35 - W121 - D92"
Cabaret coffee table.
Anteprima armchair.
Elsa floor lamp.
Barisano rug.
Decorative cushions.



Both the headrest and
armrests are adjustable -
because even relaxation can
be tailored to your needs on a
Natuzzi-Italia sofa.



anteprima

designed by
Claudio Bellini



Compact and refined,
Anteprima will fit in anywhere,
from the lounge to the
bedroom.

Anteprima armchair shown
in Essential leather with glossy
chromed feet. (738)



The combination of the bed function and the headrest that can be adjusted to take a variety of different positions makes it ideal as both a bed and a sofa.



notturmo

A sofa which is as invitingly restful as a bed? Or a bed which is as versatile and as easy to lounge on as a sofa? Notturmo solves the dilemma by delivering the best of both worlds and, with its compact design, it lends itself to the most diverse living requirements.

designed by
Natuzzi Design Center



One simple gesture and the bed opens. The magic and innovation of the Pronto-Letto system.

Notturmo chaise sofa with bed shown in Smart fabric.
H76/94 - W254 - D167 cm
H30/37 - W100 - D66"
Bis pouf.
Fil Rouge writing desk.
Galileo table lamp.





fil rouge

designed by
Mauro Lipparini



A variety of surfaces and materials to decorate both a living area and an office - but only one **Fil Rouge** that always leads back to balance and harmony.

Fil Rouge desk shown with a smoked oak - burnished-black metal frame and white volakas-marble top.

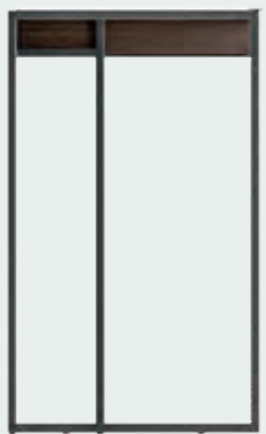

designed by
Natuzzi Design Center

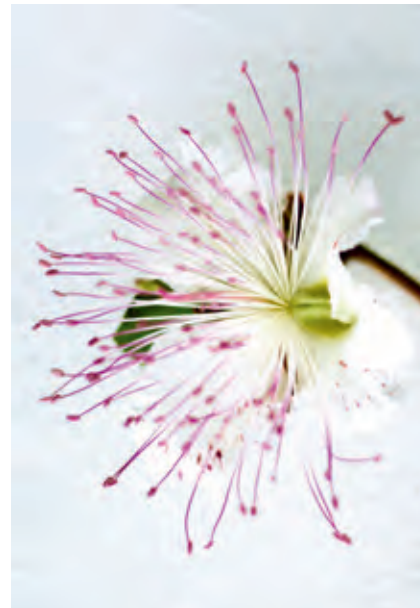

capriccio

It is a sofa bed with a square compact silhouette which has been fitted with our exclusive *Pronto Letto* mechanism; at the flick of a wrist, the sofa turns into a bed and then back again, while also boasting a hidden storage unit to stow away pillows and bed linen. An ideal solution for urban spaces.



Capriccio is a sofa bed with a square compact silhouette which has been fitted with our exclusive Pronto Letto mechanism; at the flick of a wrist, this mechanism turns the sofa into a bed and then back again, while also boasting a hidden storage unit to stow away pillows and bed linen.

Capriccio sofa
shown in essential leather
Saturday coffee tables
Colosseo floor lamp



Capriccio is an extremely versatile solution for urban spaces thanks to its dual nature, provides a new refreshing take on the idea of comfort, created by a brand which has turned comfort into a lifestyle.

The metal feet are available in various finishes and with contrasting piping as an option.



re- vive

designed by
Formway Studio

hi-tech,
hi-relax.

We have always been innovators. It is just the way we are wired and Re-vive epitomises this aspect of our nature, as if it were a symbol or an icon of who we really are. Our instincts led us to look beyond our horizons and push the envelope until we completely turned around the concept of a reclining armchair and the way it is used. A total game changer, just like the one in the '80s when Pasquale Natuzzi transformed the image of the leather sofa for ever. And much like then, it all stemmed from an idea that is as simple as it is ...well, revolutionary: find a way to make the armchair adapt to the shape and movement of the body, rather than the body adapting to the armchair. When you try Re-vive, you experience a never-felt-before sensation. It is as if the armchair were alive and had a soul. Actually, it does have one. A technological soul that is the result of top-level ergonomic engineering bringing together as many as 120 main components, 80 of which are made using exclusive moulds. A project for which we put together a real dream team, pooling Natuzzi's know-how with the knowledge of the Formway Design Studio, the most advanced centre for performance-seating research and design in the world.



We hatched the idea for Re-vive and developed it with Kent Parker, the studio's project director. It took over two years to finish the various phases of experimentation and research. We began by looking at the multi-dimensional movements found in nature which combine strength and flexibility, from the branch of a tree to the human spinal column. This helped us to identify a model that would be our base for the perfect armchair - one that would evenly distribute the weight of the body and keep it balanced in a neutral way. What ensued is an armchair equipped with innovative technology and unique features, such as the Responsive Recline - a weight-compensation mechanism that intuitively detects changes in body posture - the adaptive armrests, complete movements that reach 360 degrees from the base and a tilting footrest. But that's not all. Re-vive is like nothing you have known before. Striking a perfect balance between aesthetics and design, it bears witness to the sheer excellence of Italian design - in this case, Natuzzi design.



Watch Re-vive
in motion



an experience that is unique 9 times over

Honoured with the Trophée de l'Innovation at the Espritmeuble Furniture Fair of Paris, a gold at the Best Design Awards and other prestigious international accolades, Re-vive is an experience that is not easy to describe in words. It is like entering another dimension in which you unplug from the rest of the world and reconnect with the deepest part of yourself. A restorative regenerating respite - from the world and its hectic pace.

1 You move, and Re-vive moves with you. Automatically, without any need for external levers or mechanisms.

2 You forget about the force of gravity. Re-vive kicks in with a gentle rocking movement.

3 You lean back, you stretch out or you curl up. Re-vive's spinal column moves with you and provides constant support.

4 You choose the position. Re-vive follows your lead, turning in a circular fashion, twisting around in the lower-back region and reclining.

5 You are totally free to relax. The adaptive armrests follow your movements, effortlessly sliding back and forth.

6 You turn, and turn and turn. Re-vive moves with you, naturally and safely at 360°.

7 You are lulled into a state of relaxation. Re-vive supports you with a filling that adapts to your body.

8 You rest, you become drowsy and you fall asleep. The footstool provides your feet with support, adapting to all your movements.

9 You sit however you want. Re-vive accompanies you fluidly and naturally, without any clunkiness or jolts.



innovation meets natuzzi stylishness

By bringing together the finest Italian workmanship and the most advanced technology in the field of lounging systems, Re-vive raises the bar in terms of comfort, something that has always underpinned Natuzzi's design philosophy. But what makes Natuzzi style so unique is the fact that it gives you the pleasure of personalising each single piece of furnishing down to the tiniest detail. Re-vive is no exception to this rule.

Personalization starts with design and our Centro Stile has seven different options for you which suit all settings, tastes and personality. More comfortable, more contemporary, softer, more pristine... more yours. What is more, you can now choose between two sizes and dimensions (King and Queen) as well as a huge array of coverings (in leather and fabric) with many different combinations and a colour palette that includes over 80 variations for leather only.



quilted

Re-Vive quilted shown in Essential leather. (735)

King
H 111 - W 90 - D82/115 cm
H 44" - W 35" - D32/45"

Queen
H 105 - W 85 - D80/113 cm
H 41" - W 33" - D31/44"

In the Quilted version, Re-vive conveys a sensation of sumptuous softness accentuated by an elegant decorative trim along the edges which highlights the beauty of its silhouette and bears witness to the outstanding quality of the artisanal workmanship. A plush layer of padding (even on the footrest) means that Re-vive effortlessly bears the weight of the body while you sink into a state of ineffable relaxation.



club

Re-Vive club shown in Premium fabric. (733)

King
H 111 - W 90 - D82/115 cm
H 44" - W 35" - D32/45"

Queen
H 106 - W 85 - D80/113 cm
H 42" - W 33" - D31/44"

The large and invitingly comfortable backrest of the Re-vive Club armchair also features embellishments on the built-in headrest and footrest. Like all items from the Re-vive range, Club combines the exclusive signature comfort of Natuzzi Italia armchairs with the most advanced ergonomic technology.



casual

Re-Vive casual shown in Essential leather. (733)

King
H 112 - W 90 - D82/115 cm
H 44" - W 35" - D32/45"

Queen
H 106 - W 85 - D80/113 cm
H 42" - W 33" - D31/44"

Boasting a minimalist aesthetic, Re-vive Casual scores high on comfort. The large wraparound backrest becomes one with the headrest and merges harmoniously with the sleek-looking arms. It has been crafted from extremely hardwearing environmentally-friendly materials for a sense of well-being that ensures harmony in the broadest sense possible.



lounge

Re-Vive lounge shown in Essential leather. (734)

King
H 111 - W 90 - D82/115 cm
H 44" - W 35" - D32/45"

Queen
H 105 - W 85 - D80/113 cm
H 41" - W 33" - D31/44"

Refined and modern, Re-vive Lounge bears the unmistakable hallmark of Natuzzi artisans, as can be seen by the delicate padded quilting on the backrest which has been done by hand and repeated on the footrest too. A soft embrace that pampers you and helps you to relax.

wing back



Re-Vive wing back shown in Premium fabric. (736)

King
H 115 - W 95 - D85/117 cm
H 45" - W 37" - D35/46"

Queen
H 110 - W 90 - D80/115 cm
H 43" - W 35" - D31/45"

With its comfortable protective shape and invitingly generous backrest, Wing Back offers unsurpassed comfort, further boosted the highly distinctive design of the headrest which looks like a pair of wings opening out to embrace you and lifting you upward into flight until you reach a plane of relaxation that allows you to leave all your worldly worries behind.

shuttle



Re-Vive shuttle shown in Essential leather. (735)

Queen
H 106 - W 89 - D95/128 cm
H 42" - W 35" - D37/50"

Floating in space like an astronaut, free of gravity. The Shuttle version of Re-vive has been designed to give you that same sense of lightness and letting go. Elevated by the artistry of Mauro Lipparini, this armchair raises the bar in terms of individualised comfort. Its large trademark side wings convey a sense of welcoming and protection. The sumptuous unstructured padding comes as close to deep and intimate as you could expect from an armchair so you can claim your own space, dive into your favourite book or music and just enjoy your own personal universe.

myway



Re-Vive myway shown in Stylish leather. (734)

King
H 110 - W 99 - D97/130 cm
H 43" - W 39" - D38/51"

Queen
H 108 - W 92 - D91/124 cm
H 43" - W 36" - D36/49"

Mauro Lipparini revisits Re-vive - his way, of course - and puts his own stylish and instantly recognisable stamp on an armchair that boasts outstanding visual comfort and beckons you to sink into its soft silhouette. Superlative Natuzzi workmanship is showcased by the quilting on the backrest and seat which not only testifies to the sheer skill of the upholstery work but also elevates this item with a decorative inflection. A sartorial piece of prêt-à-porter which will fit seamlessly into a contemporary lifestyle and suit any setting, however tricky, and any customer, however discerning, because it is in a league of its own in terms of craftsmanship and design concept.

610



Re-vive 610 shown in Essential leather. (736)

King
H 111 - W 90 - D82/115 cm
H 44" - W 35" - D32/45"

Queen
H 105 - W 85 - D80/113 cm
H 41" - W 33" - D31/44"

Ergonomic comfort, cutting-edge technology and functional design are combined to give the best relaxing experience. The large comfortable backrest is a continuous invitation to relax and enjoy the ultimate comfort of the Re-vive technology, while its linear design makes it suitable for any style of furniture. The chair is covered with superior quality leather or fabric in a wide variety of colours.

re-thinking re-vive.

Re-vive has smashed many records, but there is one we are especially proud of: it is the first "performance recliner" in the world. The Re-thinking Re-vive project sprung up around Natuzzi Italia's iconic product. This basically uses the armchair as a "blank canvas" upon which the creativity and different viewpoints of great international artists are unleashed. This project pushes back the boundaries of design because it sees Re-vive as an object/space turned over to art which is then left free to express itself in keeping with the values that identify the brand - its visual codes which draw inspiration from Mother Nature and Apulia. This project has graced the most important places and events for design, including the London Design Festival, the New York X Design festival and the Salone del Mobile Milano-Shanghai.



And it provides further proof, should proof be needed, that beauty is a product of the meeting and intermingling of different cultures. And this is true today more than ever. This concept first formed a foundation for our idea of harmony more than sixty years ago. And the fact that confirmation also comes from this encounter with art and artists drives us to pursue our quest for a lifestyle that resides - increasingly so - in the art of living and dwelling.



dining

the harmony
of new everyday
habits.

In the Mediterranean culture, the places in which we entertain our friends and families, sharing thoughts, emotions, glances, food, wine and wonderful moments, are very special. And sitting around the table is always enriching, joyful, a celebration. In addition to all of this, the new normal brings with it the need to make the most of our spaces, with tables that can be transformed into well-equipped desks and multifunctional work surfaces, changing shape and size depending on the type of "meeting". The Natuzzi Italia dining room collections are the result of in-depth stylistic and functional research, experimentation with innovative and sustainable materials, respect for the relationship between tradition and local culture. Chairs and tables, storage units and sideboards, give rise to infinite harmonious combinations and dynamics perfectly attuned to the most fluid of lifestyles.

designed by
Marcel Wanders studio

adam

A timeless elegance and design distinguishes the Dining Adam, an important protagonist of the Natuzzi Italia Dining area. Adam dining table is characterized by natural colors and elements such as wood and new innovative stone finishes that are skillfully and elegantly mixed with the oldest craft history of Puglia. An offer that is the result of stylistic research involving shapes and materials.



Adam Elliptical-shaped dining table available in two sizes, suitable for 6 up to 10 people.
L280 - P100 - H75 cm
L110 - P39 - H30"

Edgar chair



Adam dining is a new organic shaped product available in two sizes where natural colors, wood and new innovative brushed lecce stone finish are skillfully and elegantly mixed.

The brushed lecce stone finishing is an innovative stone-effect texture and it is made with natural and recycled materials that create natural, unique and valuable surfaces giving each element an iridescent and distinctive note.



The harmonious contrast between the solid wood base and the smoked glass top enhances the choice of materials - a strategy to express one's taste in contemporary domestic spaces.

designed by
Marco Piva

aliante

Aliante is an extendable table surprising for its personality, design concept and strong aesthetic, which even becomes an element of lifestyle. A table which, due to its essential nature, lends itself to enhancing any combination, starting with the chairs, which are the first "characters" required to enrich the dramatic plan.



Aliante extendable table
shown with solid black Ash
wood legs and White Siena
ceramic top.
L180 (ext. 270) P100 H75 cm
L70 (ext. 106) P40 H30"
Nanà chairs.

The perfect example of
"Mediterranean rationalism",
as Piva himself defined it, the
Aliante celebrates conviviality
both in its narrowest, most
familiar dimension, and in
its widest one enjoyed with
friends.

Natuzzi Italia's attention to
innovation is all in one detail,
functional yet aesthetic: the
mechanism that enables
extension and changes the
shape of the top, creating
a continually changing
architectural game.





A traveller first and designer second, **Marco Piva** studies and creates design solutions marked by their stylistic freedom. He defines his language as “exciting, fluid and functional”, designing works related to architecture, products and interior design. Design innovation and continuous research – in technology and materials – have enabled Studio Marco Piva to be awarded very important, high-profile projects all over the world, from the innovative Next 21 residential complex in Dubai to the prestigious Excelsior Hotel Gallia in Milan, from the concept of Bulgari shop windows all over the world to the renovation of historic buildings in Venice, Milan and Shanghai.

“It’s important that a multifunctional object also has a strong aesthetic element within it; a lifestyle trait. This is what I mean when I speak of ‘Mediterranean rationalism’.”



designed by
Massimo Iosa Ghini

gutta

Gutta is a triumph of organic form, with its fluid, sinuous lines and a surface that resembles an uneven mirror of water reflecting everything around it. The new domestic design approach looks to nature as a model of maternal, inclusive beauty, never aggressive or edgy. A 'human' beauty, more in harmony with who we are.

The timeless elegance of the table, available with a round or oval top, breaks the mould and redefines the boundaries of the aesthetics applied to design.





Gutta dining table shown with a structure in solid American walnut and a top in Calacatta Gold marble. L220 P118 H75 cm L86 P46 H30"
Beat armchairs.
Circle pendant lamp.

A lightweight structure in solid walnut emphasises the sinuous shapes of the table, starting from the legs, which seem to be modelled by function, and ending with the profile of the top.



beat



designed by
Mario Lipparini

The **Beat** armchair welcomes us with its generous seat. Enveloping us like a corolla of petals, reassuring us like a nest.

Baet armchair shown in Nabuk.



Natural and hi-tech materials blend harmoniously, giving the table an image that is both classic and contemporary

Libra dining table shown with a structure in white polished Carrara marble and a top in BETACRYL® Pure Acrylic Stone. L240 P110 H75 cm
L95 P43 H30"
Edgar chairs.

designed by
Claudio Bellini

libra

With its sleek, subtle lines and legs that seem to balance on one edge, Libra appears to defy gravity. Sinuous marble legs that play on the contrast between the solidity of this material and the lightness of the design. Libra is also available in a circular version for more compact spaces.





libra

designed by
Claudio Bellini



Libra table is designed with the idea of creating an illusion to the very thick and bold mass of the marble material. A simple curve on the legs gives an immediate light-weight feeling as though the table is dancing.

Libra dining table shown with a structure in white polished Carrara marble and a top in BETACRYL® Pure Acrylic Stone.
D140-160 H75 cm
D55-63 H30"



designed by
Claudio Bellini

virgola

The new and diverse space requirements of the contemporary home are the inspiration for Virgola, an extendable table that celebrates and exalts conviviality, beginning with the design. In fact, the tabletop is in FENIX® - a hi-tech and very resistant, anti-glare, scratchproof and anti-fingerprint material - while the extension has a marble finish which creates a break and highlights the addition of other seats, becoming a highly aesthetic as well as functional element.



Virgola extendable table shown with legs in metal tubular with laser cut processing - in coffee black finish - and top in FENIX cacao orimoco finish. L180-230 P100 H74 cm (extension L50- W100 cm) L70-90 P40 H29" (extension L20- W40")
Edgar chairs.
Urchin vases.

Soft, rounded lines and a high backrest that ensures optimal comfort. **Edgar**, with and without armrests, is an upholstered chair that puts everyone at their ease.



designed by
Claudio Bellini

ombra

With its weight-bearing asymmetrical leg in innovative concrete-effect Bio-mortar, a top with a wooden finish and a gleaming metal base, Ombra bespeaks its exquisite workmanship. A table suitable for both modern living, dining, and office spaces with a strong identity.



Ombra dining table shown with a pewter steel base, asymmetrical frame covered in light-grey concrete-coloured decorative bio-Mortar and a top in tobacco-brown ash wood.
L240 P120 H75 cm
L 94,4" P47,2" H 29,53"
Vesta chair.
Dami pendant lamp.
Fortuna sideboard.
Sophia B rug.





fortuna

designed by
Claudio Bellini

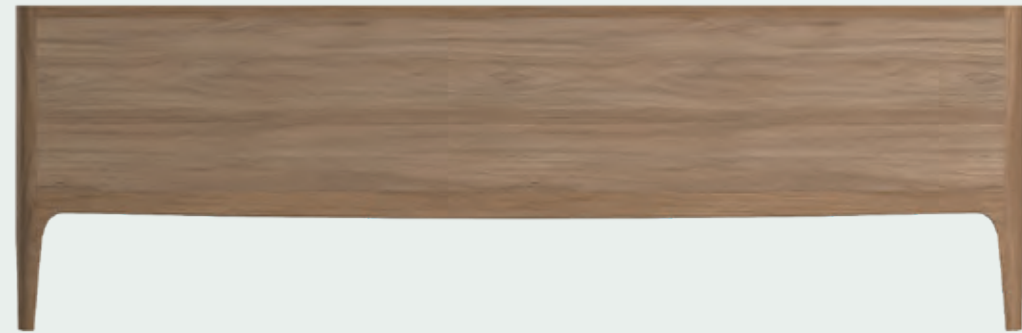
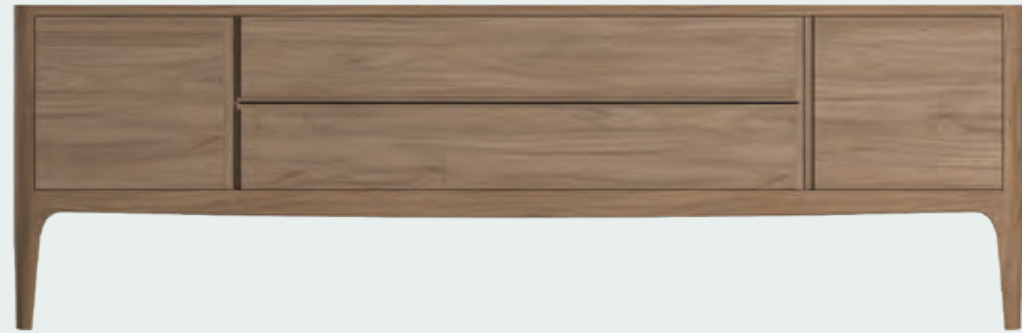

A rare pristine design
with a timeless feel.
Fortuna, the sideboard born
under a lucky star.

Fortuna sideboard shown
in ash wood with a tobacco-
brown finish.

designed by
Nika Zupanc

voyage

Voyage is half-table and half-sculpture, with a sensually sleek silhouette which will steal the scene wherever you put it. The top in Stardust - Terrazzo Stone - features a rare mixture of iridescent marble which takes its cues from the star-studded skies on balmy summer nights. An extraordinary object which resonates on a deep level.



Voyage dining table
shown with light-gold
metal base - top in
Stardust Terrazzo Stone.
L 220 P110 H 75 cm
L 86.61" P43.31 H29.53
Voyage chair.
Joy pendant lamps.
Mermaid mirrors.
Adore armchair.
Vortex rug.
Pumo craft items.





voyage

designed by
Nika Zupanc



Sinuous and glamorous, the **Voyage** swivel chair completes the dining area of the Deep collection.

Voyage chairs shown in Stylish fabric with base made in steel with a matte, light-gold satiny finish.

joy

designed by
Nika Zupanc



Joy fills your home with the soft glow of happy evenings spent on the beach.

Joy pendant lamp shown with a light-gold finish, white matte ceramic details and an iridescent glass sphere.



voyage



Voyage Dining table with a light-gold metal base and a top in a Gold & Glass colour palette with a personalised design.

designed by
Mauro Lipparini



campus

Campus features an ageless design with an acutely contemporary aesthetic. Exquisite materials and sleek lines unite to create sheer perfection. Its elliptical top available in several shape and size finished with either marble or ceramic will take centre stage in the living area, lending itself effortlessly to a whole array of different décor styles.

Campus dining table
shown with a top in
Calacatta Green marble
and a glossy champagne
metal base with
ash-wood details.
L 210 - P110 - H75cm
L 82 - P43 - H29"
Valle chairs
Campus sideboard
Pumo craft items
Colosseo arch lamp
Sophia B rug.

Campus dining has
an extraordinary
scenic effect the use
of marble and ceramics
in large format for
its tops, together with
noble stone, technical
materials and metals.
A design with a
unique and distinctive
personality, but at
the same time elegant
and refined.



campus

Valle chairs.
Campus TV unit.
Dami pendant lamp.



A round version is designed to maximize any space and offer greater flexibility of seat and it's ideal for 6 - 8 seats.

A large rectangular version is an ideal solution to accommodate more people and to be the undisputed protagonist of the room.

Campus round dining table shown with a top in Macchia Vecchia marble and a glossy black chrome metal base with eucalyptus wood. Ceramic is a material suitable for various environments thanks to its ease of maintenance, and resistance.

campus



designed by
Mauro Lipparini

In the **Campus** sideboard, the graphic linearity of the backlit cabinet doors is counterpointed by rounded corners in a harmonious blend of different styles.

Campus sideboard shown with a tobacco-brown ash-wood frame and a glossy champagne metal base with wood details.

The contemporary and rigorous design of **Campus** is also developed in the eucalyptus wood TV unit that can bring a touch of elegance and functionality to any living room. The compartments and shelves allow you to insert technological devices and hide TV cables.



The warmth of wood and the glint of metal create a strikingly unique counterpoint to each other.

designed by
Manzoni&Tapinassi

kendo

Merging Mediterranean harmony and Eastern balance, the Kendo table will contribute to the creation of a refined and extremely characterful dining area. The mixture of solid wood and metal gives life to an unparalleled interpretation, a perfect blend of artisanal artistry and deft design.

Kendo dining table shown with legs in solid smoked oak wood with a brass metal insert. Top in smoked oak.
L 260 P 100 H 74 cm
L 102.36 P 39.37 H 29.13
Ambra chairs.

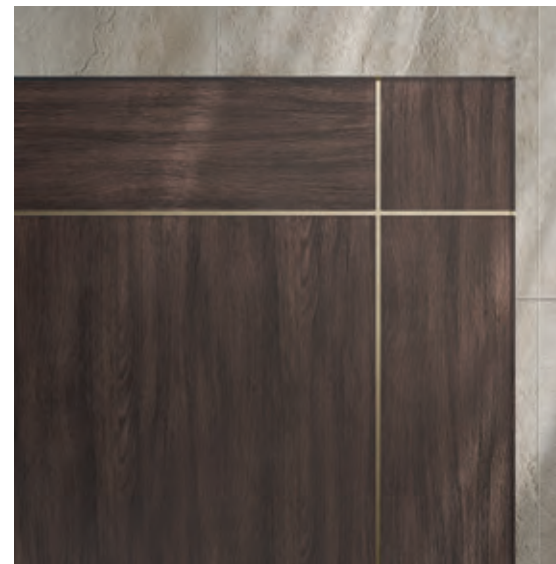



kendo

designed by
Manzoni&Tapinassi



Exquisite cabinetwork is a sure mark of superlative Italian craftsmanship. The **Kendo** sideboard.

Kendo sideboard shown in solid smoked oak wood with a brass metal insert.

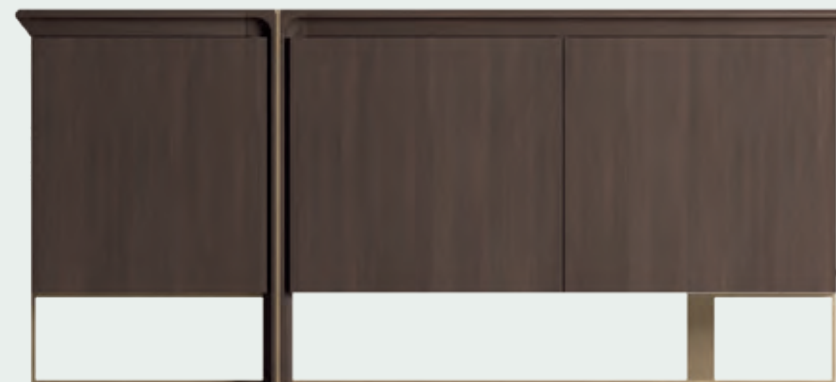

kendo

designed by
Manzoni&Tapinassi



Like a **Kendo** sword, the eponymous lamp creates a clever contrast between the warmth of wood and the lustre of metal.

Kendo table lamp version shown in walnut with a brass insert and white lampshade.



ambra

designed by
Natuzzi Design Center



Visual softness and great comfort. **Ambra** - an irresistible invitation to take a seat.

Ambra chairs shown covered entirely in Essential leather.



designed by
Claudio Bellini



new saturno

New saturno's contemporary pared-back design boasts harmoniously sleek curves which create an incredibly visually striking effect. The structure in various types of solid wood combines with an elegant satin-finish glass top for a timeless feel.

All the prowess of Italian workmanship is embodied in one detail: the hand-applied ragging-paint finish which accentuates the sheer beauty of the wood.



New Saturno dining table shown with legs and frame in solid smoked oak wood and a top in coffee-brown etched glass.
L 200 P100 H 74 cm
L 78.74 P39.37 H29.13"
Sovrana chairs.
Circle pendant lamp.
Fortuna sideboard.
Pumo craft items.
Galaxy sofa.





sovrana

designed by
Claudio Bellini



Sovrana elevates any setting with its comfortable lofty elegance, whether it be the dining room or the lounge.

Sovrana chairs shown in Essential leather with solid smoked oak wooden frame.

designed by
Mauro Lipparini

phantom

Set on two panes of ultra-clear almost invisible glass, the top seems to float in mid-air. The visual purity of Phantom's silhouette brings together two opposites: the grandeur of wood and impalpable nature of glass; a matte surface and a transparent one.





Phantom dining table shown with a base in extra-clear glass frame and a top in walnut.
L 260 P105 h 74 cm
L102.36 P41.34 H29.13"
Frida chairs.
Chocolat mirrors.
Phantom sideboard.



chocolat

designed by
Natuzzi Design Center

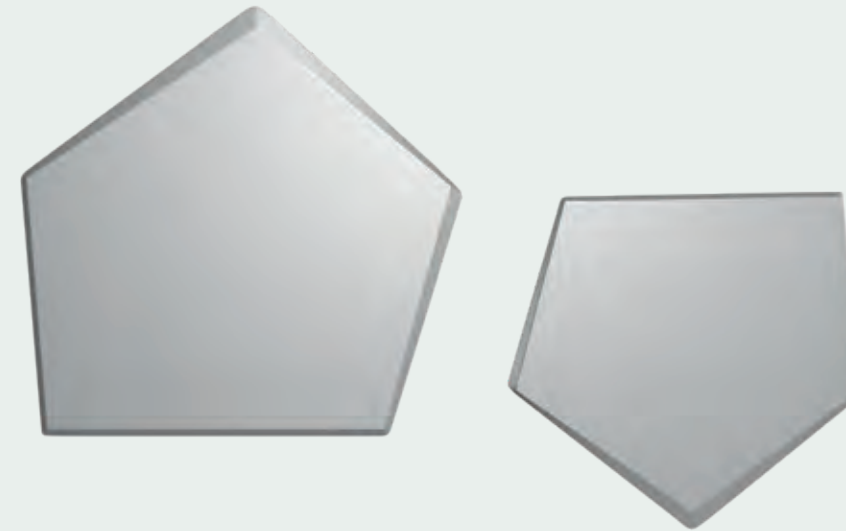

Combine various **Chocolat** mirrors and create a series of refined geometrical angles.

Chocolat mirrors shown in silver-tone mirrored glass.

frida

designed by
Mauro Lipparini



A sleek silhouette and a streak of eccentricity. **Frida**, as exuberant and modern as the artist that inspired it.

Frida chairs shown in dark-brown full-grain leather.

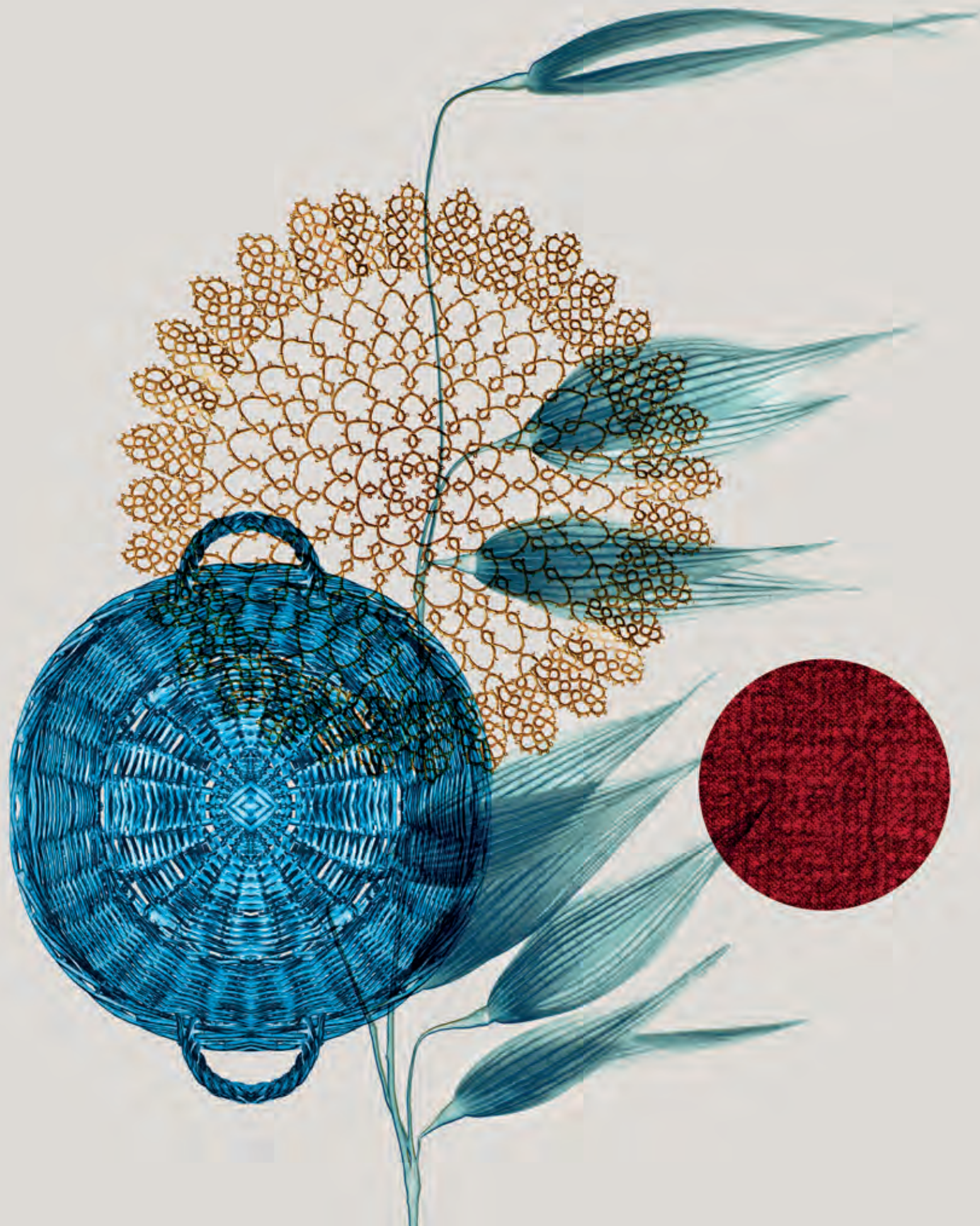

bed room

harmony,
a dream that
comes true.

For this most intimate and personal of spaces, Natuzzi Italia has developed a collection of beds, bedside tables and chests of drawers that perfectly encapsulate its expertise and vision: the value of Made in Italy artisanship and processes that respect the environment, the exclusive comfort that has made it a household name all over the world, attention to detail, quality materials - from the best wood, originating from correctly and responsibly managed forests, to the finest leathers and through to the most exclusive and innovative fabrics, the fruit of synergies with the most cutting-edge businesses in the field of sustainable textile design. To create a space that combines the real with the ideal, a collection of dreams that inhabit reality.

campus bed
shown with headboard
in suede leather with
unevenly woven pattering
L108 - P210 - HP217cm

campus panca
shown in suede leather
with unevenly woven
pattering
L120 - P42 - H42cm

designed by
Mauro Lipparini

campus

Campus bed draws its aesthetic origins from the extraordinary craftsmanship of its broad weaves made of leather straps woven orthogonally in a modulated rhythm: a confirmation of Natuzzi Italia's high quality craftsmanship and attention to sartorial detail. A geometric purity that gives a pleasant sensation, a true invitation to relax. Elegance, exclusivity and uniqueness make Campus an iconic, representative and familiar bed, and at the same time a distinctive protagonist of home furnishing.





The Campus night program combines furnishings and bed and creates a new interior proposal with dressers and elegant and functional compartments and bedside tables that rewrite the function of the bedroom and express the details of the craftsmanship with a contemporary key.

The elegant design of Campus bed finds its maximum expression in the headboard, softly padded and embellished by suede leather with headboard in suede leather with unevenly woven patterning. Cushions can be upholstered in leather or fabric, and are removable.



campus bedside table

designed by
Mauro Lipparini

The theme of bedside tables is developed according to the logic of diversity. Although they unequivocally belong to the same aesthetic dimension, they are conceived to be used in pairs or separate in the bed coordination.

The highest bedside table is a real concealed storage unit accessed by a sliding top. The regular hexagonal volume, with its delicate features, is supported with graceful balance by a central metal leg.

The lower version is an elongated hexagon, configured with two tops supported perimetrically by a row of solid wood rods: an ideal reference to oriental aesthetic languages.

exagonal bedside table
L47 - P42 - H52cm
L19 - P17 - H20"

bedside table
L70 - P41 - H45cm
L28 - P16 - H18"



campus dressers

designed by
Mauro Lipparini

Campus reinterprets the evergreen and contemporary design of the bedding area in function of a new area known with a refined identity and modern decoration.

Night dresser, chest of drawers and bedside tables provide a base in laser cut steel sheet, polished and liquid painted in glossy black chrome. The metal base features details with eucalyptus wood inserts. Tops are in glossy lacquer and the drawers are equipped with side opening with soft closing.

dresser
L70 - P55 - H135cm
L28 - P22 - H53"

chest of drawers
L170 - P55 - H74cm
L67 - P22 - H29"

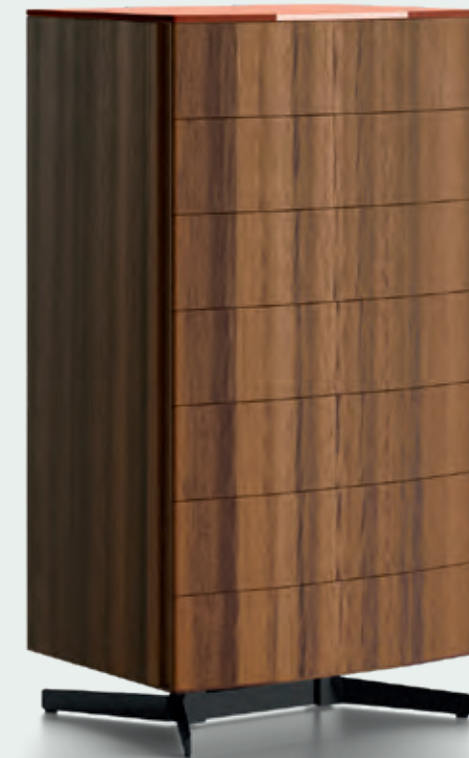

designed by
Natuzzi Design Center

pincha

The Pincha bed has a simple and elegant design that suits any lifestyle and decor. The headboard is also upholstered in the back allowing the bed to be placed even in the center of the room.



Pincha bed shown
in Lemans leather
L 207 - P244 - H 108 cm
Scacco pouf
Fenice bedside table
Fenice sideboard
Kendo mirror
Vico lamp



Pincha has multiple sizes to meet every space requirement, and also offers the option of upholstering the bed with Natuzzi Italia's wide range of leathers and fabrics. Available also with storage function.



scacco

designed by
Natuzzi Design Center



Comfort and design follow you everywhere. Scacco's polystyrene padding makes it light and easy to transport wherever you want to enjoy your home. It easily adapts to your seat, giving you all the comfort you desire. Available in fabric in a wide range of colors with leather logo bands.

designed by
Patrick Norguet

ema

Poly is a furniture collection designed to create a new, multi-purpose harmony between relaxation and the work space. A transition towards fluidity, with designs such as Ema - a bed that rewrites the rules of domestic life, the essential feature of a sleeping area where the most conventional forms of visual comfort meet the demands of contemporary living.



Ema combines a linear design with aesthetic details that amplify the concept of relaxation. Four sizes are available, depending on varying requirements of space.

The headboard is padded and enriched with stitching that also appears on the bed frame, which emphasises its softness.

Ema bed shown in Trendy fabric.
H142 - W232 - D218 cm
H56 - W91 - D86"
Labirinto bedside tables.
Sophia B rug.





nanà

designed by
Patrick Norguet

We combine design, function, colour and materials to create harmonious, iconic products.

Like the **Nanà** chair, an elegant, upholstered seat with three different bases to choose from, making it suitable for all possible uses and combinations.



inu



designed by
Patrick Nourguet

Inu, a table-desk with a large worktop made from FENIX, a material that heals itself in the event of scratches, and details such as the hidden cable duct. The expertise and vision of the brand is also in that which is unseen.

Inu table-desk shown with structure in natural Ash wood and top in FENIX.

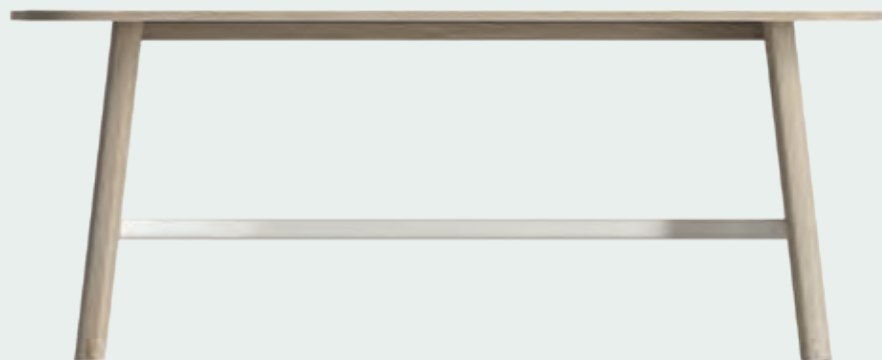



Patrick Norguet approaches objects and design from a graphic perspective. His 'practical' approach, based on his industrial and design studies in Paris (ESDI), is what defines the unusual profile of this constructive rebel. In 2000, he founded his Paris studio, immediately establishing himself as a key figure on the international scene. His greatest passion is dialoguing with manufacturers and discovering their expertise; the creative impulse refined by technical constraints. He does not follow trends, but seeks to design relevant, modern products that stand the test of time: "A well-designed object, an object created through generous collaboration, is timeless."

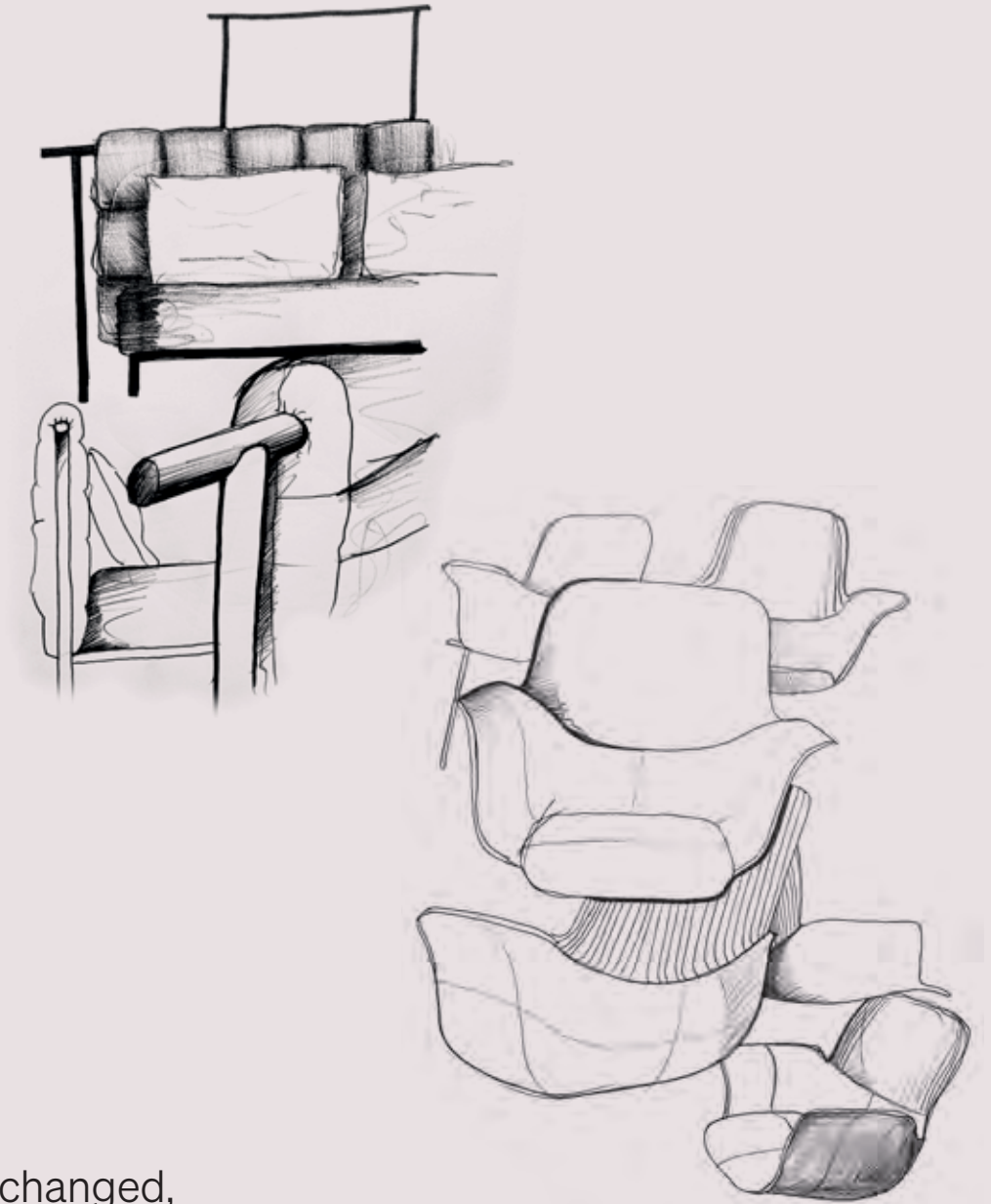

"Priorities have changed, especially among the younger generation - people are looking for products that have good energy, and tell a lifestyle story."

designed by
Claudio Bellini

Allow it to take centre stage and play a starring role in your bedroom. The headboard has been finished to a high standard on both sides so it can be showcased in the middle of the room.

briq

Available in four different sizes with leather or fabric coverings, Briq is designed to meet any space requirements. It scores high on versatility and functionality, as evidenced by the storage unit with two opening positions so you can easily access all parts of the bed.



Briq bed shown in
Essential leather.
H113 - W230 - D236 cm
H44 - W91 - D93"
Svevo bedside tables.
Vico lamp.
Sophia B rug.



svevo

designed by
Manzoni&Tapinassi



The frame rests elegantly on feet in solid wood with a metal detail, the leitmotif of the **Svevo** collection.

Svevo chest of drawers version in smoked oak with brass metal finishes.

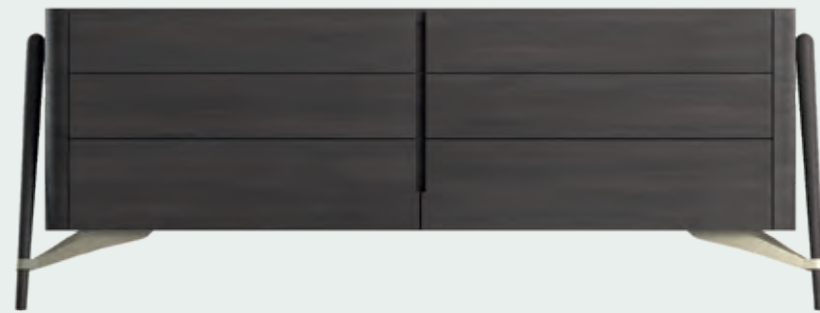

designed by
Claudio Bellini



cala

With its exquisitely elegant design featuring a plush headboard and tailored details on the back and the front Cala can proudly take its place in the middle of the room. Its distinctive shape reminiscent of a spectacular seascape in the midst of uncommon beauty invites you to take your time and sink into its restorative embrace.

The refined aesthetic of the headboard featuring uncomplicated vertical topstitched lines imbues it with a sense of dynamism and gives it character.



Optional secret box
with a pull-out drawer
for easy storage of
belongings and bedlinen.



Cala bed shown
in Essential leather.
H88 - W245 - D227 cm
H35 - W96 - D89"

Cala bedside tables.
Galileo table lamp.
Trullini room fragrance.
Tailor mirror.
Sophia B rug.



cala

designed by
Claudio Bellini



Available in the same coverings as the bed, the **Cala** bedside table is a perfect match for the bed.

Cala bedside table shown with a dark-brown leather frame and a coffee-brown glass top with shelf in walnut.

cala

designed by
Claudio Bellini

The Cala bedroom collection - chest of drawers and bedside table. Completely upholstered in saddle leather, the sleek-looking sides exude linear elegance and bespeak all the artisanal expertise that went into creating these pieces.

Cala chest of drawers shown with a dark-brown leather frame and walnut top.



designed by
Manzoni&Tapinassi

diamante

Diamante means diamond in Italian and, as heralded by its name, it's like a treasure chest in the bedroom area. Its comfortable and curvaceous headboard, artisanal topstitching on the leather covering, premium materials and exquisite haute-design detailing emanate an air of preciousness.

Both the sides of the bed and the back of the headboard are fully padded and upholstered.





Diamante bed shown
in Performance fabric.
H85 - W174 - D240 cm
H33 - W69 - D94"
Euclide bedside tables.
Galileo table lamp.

The sleek stylishness
of the feet in
lacquered metal.





euclide

designed by
Manzoni&Tapinassi

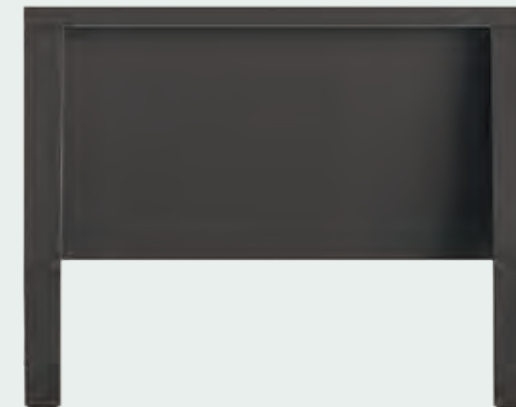

The bedside tables from the **Euclide** collection are pared-back and breezy. And the drawers have plenty of room for your dreams.

Euclide bedside tables shown with a matte coffee-brown lacquered finish.

euclide

designed by
Manzoni&Tapinassi

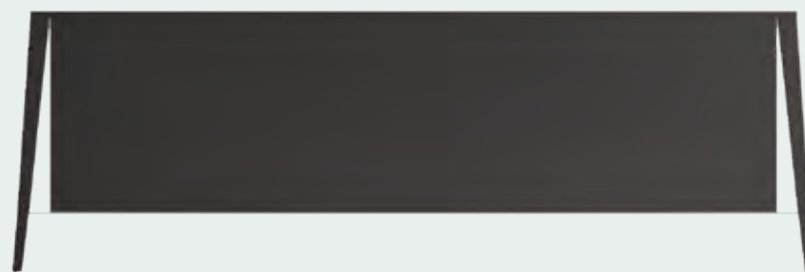

In the sideboard from the **Euclide** collection, modernity extends to both form and content.

Euclide chest of drawers shown with a matte coffee-brown lacquered finish.





designed by
Manzoni&Tapinassi

dolcevita

A glamorous vintage vibe and a supreme comfortable design beckons you to sink in and succumb to self-indulgence. Its large and lavishly elegant padded headboard brings to the fore the exquisiteness of the hand-tufting. This is a bed for a Natuzzi Italia night filled with Italian dreams.

Upholstered at the back as well, the headboard has been meticulously designed and brings out the beauty of the artisanal workmanship.





Dolcevita bed shown
in Premium fabric.
H132 - W240 - D233 cm
H52 - W94 - D92"
Munari chest of drawers
and bedside tables.
Pumo craft item.
Colosseo table lamp.
Circle table lamp.
Vortex rug.



munari

designed by
Manzoni&Tapinassi



A designer and artist, Bruno **Munari** was in love with purity and held that simplicity is a sign of intelligence. The homonymous chest of drawers pays tribute to him with a refined and characterful shape enriched by a series of premium materials.

Munari chest of drawers and bedside tables shown with a smoked oak-wood finish. Chest of drawers with calacatta gold marble top.

circle

designed by
Massimiliano Raggi

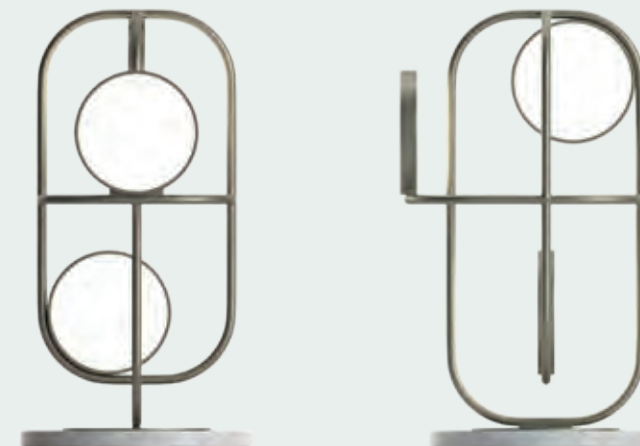

A refined play of lights. The ideal way to brighten any setting.

Circle table lamp version shown with brass frame and white lampshade.

designed by
Bernhardt & Vella

fenice

Fenice is the bed which effortlessly brings together aesthetics and function in a triumph of finesse. The slightly tilted headboard provides a highly comfortable posture for reading and, obliquely inclined as it dovetails with the bedframe, it also creates an elegant geometric detail.

Cosseted by the big plush cushions on a spectacular-looking and comfortable headboard.



Fenice bed shown
in Performance fabric.
H95 - W198 - D231 cm
H37 - W78 - D91"
Melpot pouf.

Fenice chest of drawers
and bedside tables.
Galileo table lamp.
Sophia B rug.



The storage-unit mechanism has two different opening modes: the first one allows you to make the bed without bending your back, while the second one allows you to effortlessly stash away linen and any belongings in the furthest corners.





fenice

designed by
Bernhardt & Vella



Bedside tables from the **Fenice** collection. Fine design watches over you.



Fenice bedside table shown in a chalk-white glossy lacquered finish.

fenice

designed by
Bernhardt & Vella



Asymmetry, breeziness
and formal restraint.
A dream of a chest
of drawers.

Fenice chest of drawers
shown in a chalk-white
glossy lacquered finish.



Piuma bed shown
in Essential leather.
H94 - W218 - D243 cm
H37 - W86 - D96"
Mondrian bedside tables.
Vico table lamp.
Sophia B rug.

designed by
Claudio Bellini

piuma

Sumptuously soft and airy in appearance, Piuma is lifted from the ground by its open base almost as if it were floating. Suggestive of two pillows joined in the middle, the headboard offers high comfort levels. It has been trimmed around the edge with an exquisite ruffle detail lined on the inside with plush velvet.





mondrian

designed by
Claudio Bellini

A pared-back silhouette and a pristine minimalist design. The chest of drawers and bedside tables from the **Mondrian** collection pay tribute to the geometric purity of the past master of abstract art.

Mondrian bedside table shown with a matte mocha-brown lacquered surface and coffee-brown metal feet.



mondrian

designed by
Claudio Bellini

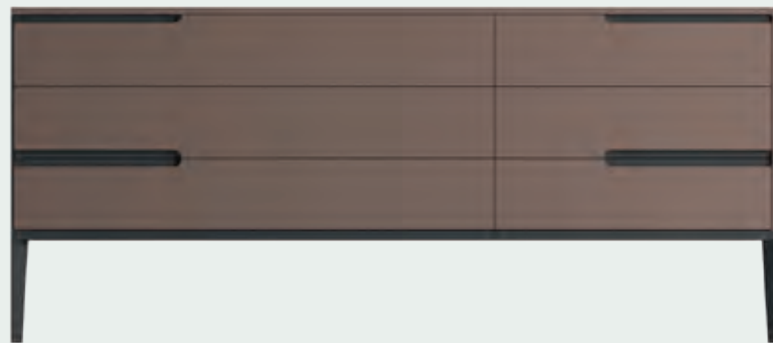

A pared-back silhouette and a pristine minimalist design. The chest of drawers and bedside tables from the **Mondrian** collection pay tribute to the geometric purity of the past master of abstract art.

Mondrian chest of drawers shown with a matte mocha-brown lacquered surface and coffee-brown metal feet.



The frame rests elegantly on feet in solid wood with a metal detail (the leitmotif of the collection).

designed by
Manzoni&Tapinassi

svevo

A combination of Fifties' stylishness and night-time glamour, the Svevo bed's defining aesthetic is voluptuousness. The large bedframe and fully padded generous headboard are a wonderful fusion of visual comfort and fine design, while the open base gives a sensation of breeziness and linearity.



Svevo bed shown in
Performance fabric.
H100 - W203 - D237 cm
H39 - W80 - D93"

Svevo bedside tables.
Vico table lamp.
Butterfly armchair.
Vortex rug.



butterfly

designed by
Natuzzi Design Center



Butterfly.
An exquisite
take on a classic
reading chair.



Butterfly
armchair shown
in Performance
fabric with wengé
wooden feet.

kendo

designed by
Manzoni&Tapinassi

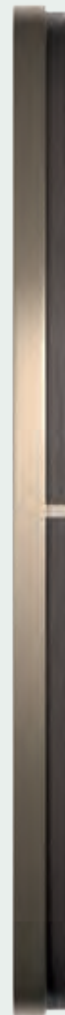

Clever contrasts and tasteful combinations in wood and metal. Reflections of a refined soul. The **Kendo** mirror.

Kendo mirror shown with a walnut, pewter and glass bronze finish.



designed by
Bernhardt&Vella

venere

In tribute to Venus, the goddess of beauty, this is a bed that symbolises feminine sensuality. The ergonomic tilted position of the headboard softly padded with premium polyurethane offers a really comfortable reading position from which you can slide down and drop off into restful beauty sleep.

Venere bed shown
in Stylish leather.
H116 - W190 - D232 cm
H46 - W75 - D91"
Tailor mirror.
Venere bedside tables.
Vico table lamp.
Sophia B rug.





Feet upholstered in premium Natuzzi leather. Superiority also emerges from a detail.



venere

designed by
Bernhardt&Vella

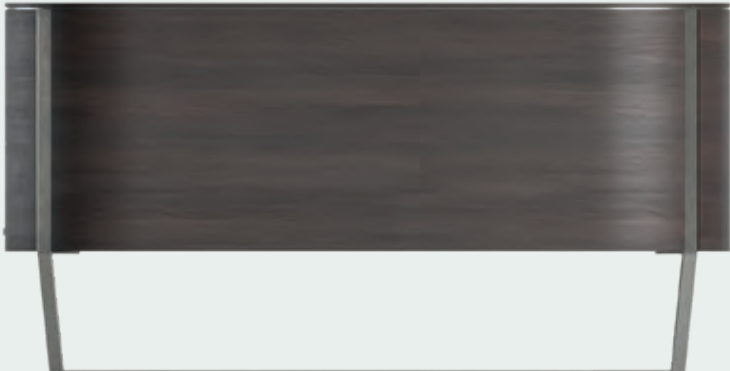
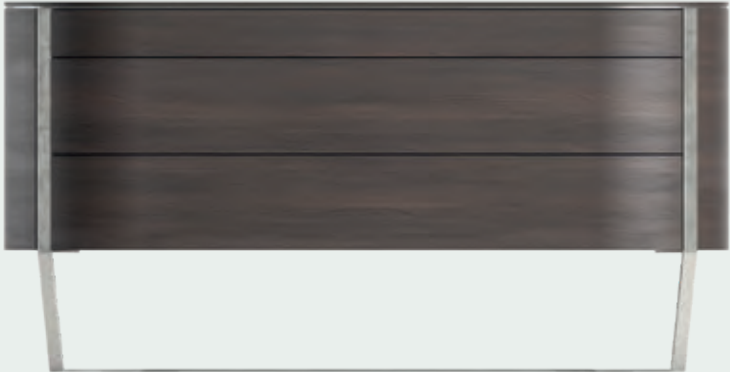

The absence of visible handles enhances the sleek curvaceousness of the design and puts the spotlight on the materials. The **Venere** chest of drawers and bedside table, an ideal addition to the homonymous bed.

Venere chest of drawers shown in walnut with glossy black chrome feet.



clouds

designed by
Natuzzi Design Center

An elegant interplay of
light and reflections for
a strong aesthetic impact.

Clouds mirror shown with
a smoky finish.





tailor

designed by
Claudio Bellini



Tailor mirror shown with a pewter frame.

Tailor boasts a contemporary minimalist aesthetic - a mirror with a natural bent for all things beautiful.

sleeping in natural harmony



Designed and entirely made in Italy, Natuzzi Italia's beds are a benchmark for those seeking the utmost harmony and quality, even when sleeping. Their perfect match are the innovative mattresses developed in partnership with Coco-Mat, a pioneering company. Completely artisanal, totally natural and ergonomic, these mattresses are essential components for an extremely comfortable and restorative night's sleep.



natural latex 25 mm (0.98")
rubberised coconut fibre 20 mm (0.7")
natural latex 60 mm (2.3")
rubberised coconut fibre 10 mm (0.39")
seaweed
natural latex 60 mm (2.3")



natural latex 25 mm (0.98")
seaweed
natural latex 25 mm (0.98")
rubberised horsehair 10 mm (0.39")
natural latex 25 mm (0.98")
rubberised cactus fibre 10 mm (0.39")
rubberised coconut fibre 10 mm (0.39")
seaweed
natural latex 60 mm (2.3")
rubberised coconut fibre 10 mm (0.39")
eucalyptus leaves
seaweed
natural latex 60 mm (2.3")



natural latex 60 mm (2.3")

Atlas mattress

Handcrafted with care using Nature's finest materials to provide maximum comfort and create the conditions for rest. Atlas will lend itself to any individual preference and you can choose between a springy and less springy side. Suitable for all body types.

materials Natural Latex, Rubberised Coconut Fibre and Seaweed.

elasticity Different on each side – Soft and firm.

height ± 18 cm (7")

cover Washable, 100% cotton.

Proteas mattress

Exquisitely handcrafted, Proteas is our most exclusive and intricately designed mattress, made entirely from natural materials. Made to embrace each curve of the body and provide optimal support to heavier parts while ensuring maximum springiness. Suitable for all body types.

materials Natural Latex, Rubberised Coconut Fibre, Horsehair, Eucalyptus leaves, Cactus Fibres and Seaweed.

elasticity Different on each side – Soft and medium.

height ± 25 cm (9.8")

cover Washable, 100% cotton.

Iviskos top mattress

A thick layer of natural latex which provides optimum springiness and comfort. Works in combination with the mattress to improve the sleep experience. Suitable for all body types. The cotton covers can be easily removed and washed for maximum hygiene.

materials Natural Latex.

height ± 6 cm (2.3")

cover Washable, 100% cotton.



materials

Natural rubber

A colloid, milky fluid which undergoes a special process to become soft elastic foam. The name given to rubber by indigenous Equator tribes was "caoutchouc", from the words "caa" (tear) and "ochu" (tree), because of the way it is collected.

Coconut husk

The husk of the tropical coconut fruit is coated in strong, resilient fibres which are sprayed with natural rubber, shaped into layers and used on our products. Coconut fibres are known for their durability and insulating properties.

Seaweed

Over the years it has been used for multiple purposes, from a medical remedy to insulating material. Once dried, we use it for its slowly-released scent of iodine. Iodine is known to benefit the breathing system.

Cotton

Used to make soft comfortable clothes and other textiles, cotton has a long history. Light, fluffy and naturally hypo-allergenic, cotton is the undisputed king of all our fabrics.

Wool

Although woollen fabrics are commonly thought to be more suitable for colder climates, in fact, wool is perhaps the only natural material that can keep us warm in winter and cool in summer, thanks to its insulating properties.

Eucalyptus

The tall eucalyptus tree is well-known for its shade and its healing properties. The essential oil distilled from its leaves has a refreshing smell and is a natural remedy, beneficial for our breathing system.

Horsehair

Over the ages it has been used to make brushes, strings for musical instruments, and even toothbrushes. Horsehair is naturally waterproof and can absorb humidity to create a dry environment.

Cactus

An excellent survivor in any environment, this exotic plant has strong and durable fibres which can regulate humidity and maintain a dry environment.

Lavender

A fragrant shrub, famous for its sweet scent and beneficial remedies, lavender is widely used in cosmetics, perfumes, balms and medicines. Its seductive aroma is known to have relaxing effects.

Down

Down has been associated with dreamy sleep due to it being lighter-than-air. Delightfully soft, it keeps us warm, thanks to its inherent ability to let air pass through, while keeping temperature levels stable.

pillows

Sithon I natural latex flakes.

Optimal head and neck support. Suitable for all body builds. Fully customisable. 50 x 70 cm.

Sithon III duck feathers & down.

Feather-light smoothness. Suitable for lighter weights. 50 x 70 cm.

Sithon V pure virgin wool.

Hypo-allergenic. Enhanced head and neck support. Suitable for all body builds. Customisable. 50 x 70 cm.

Narkissos I natural latex flakes.

Ideal for those who sleep on their side. Optimal head and neck support. Suitable for all body builds. Fully customisable. 50 x 70 cm.

a soft, warm, silky embrace

Our dream begins in Apulia where natural elements are transformed into light, depth, warmth, and colour. Then they take shape, filled with substance, matter, and more. They absorb culture, tradition, and passion. Understated luxury evidenced by attention to detail and the sophisticated craftsmanship of the finest-quality yarns. All the most up-to-date shades, weaves and a blend of traditional workmanship and modern techniques - these are just some of the typical features of our matching bed linen, blankets and decorative cushions.

Bed Linen

Timeless elegance and seduction. Natuzzi Italia's colour-coordinated bed linen expresses all the excellence of Italian design in a sartorial collection packed with exquisite details. In pure superior-quality cotton percale or in pure linen, they are finished with special hand-crafted techniques.

Cushions

In a stunning blend of Italian tradition and contemporary design, Natuzzi Italia presents an extensive collection of decorative cushions. Available in a variety of dazzlingly bright colours and in elegant natural materials. Natuzzi Italia cushions are designed to add an exquisite and harmonious personal touch to the rooms of the home.

Blankets

Pleasing to the eye and warm to the touch, Natuzzi Italia blankets convey an authentic experience of taste and style. In pure cashmere or in 100% merino wool, they are the ideal companions for curling up on the sofa on cold winter days, also doubling as decorative furnishings for your home. The superb quality and special properties of the fibres make these blankets a perfect gift for important occasions.

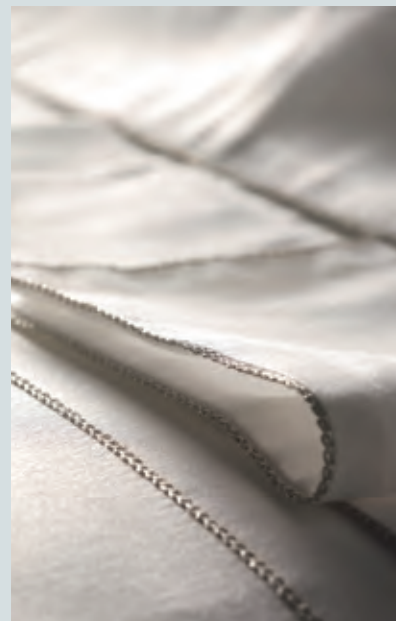



the place of harmony

a place to enjoy the true taste and intensity of the Mediterranean atmosphere



"All that inspires us becomes form, design and objects. And it is our pleasure to tell it, show it and share it all". Pasquale Natuzzi

The Natuzzi Italia store is the place where this happens every day: the setting where the brand's story and image become customer experience, the centrepiece of a multi-sensory event revolving around Italian lifestyle: the blown-up images of Apulia meld with the collections it inspires, while home fragrances and essences of Mediterranean plants mingle with the aroma of freshly-brewed espresso. The new Natuzzi vision no longer contemplates stores that specialise in products, but places where we celebrate harmony and where the classic sales process coexists with cutting-edge technology.

Natuzzi is the only player in the industry that can offer a completely new shopping experience, through a combination of innovation and creativity. The Natuzzi Augmented Store, for example, is a space where everything that a physical store has to offer is vastly amplified by Mixed, Augmented and Virtual Reality. This new shopping experience transports

the customer to a virtual showroom where they can access the entire Natuzzi Italia range, view products as if they were real, in 1:1 scale, and interact with them by changing colours and finishes. This venture has won the prestigious Retail Week Award. Natuzzi Italia, as a lifestyle brand, is forward-thinking in the way it builds strong and lasting relationships with its customers, continually seeking the best ways to accommodate them and offer them a unique and memorable shopping experience. That also means calling on the best specialist staff – architects, interior designers, consultants – who can interpret their desires in the various furniture design phases and transform them into "bespoke" solutions, customised and worked out to the last detail. It means cosseting, pampering and surprising them right until the end, when we make a "white glove delivery" of the chosen item to the customer's home, elegantly packaged and arranged with all the attention it deserves. Because the high quality of the "Natuzzi experience", what we call retail excellence, is just as impeccable and refined as its collections.

and soul matter

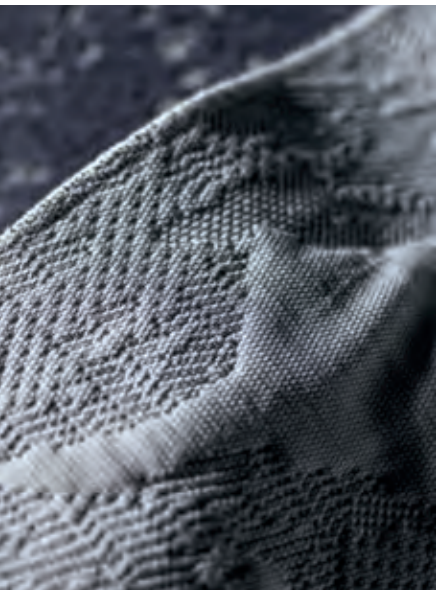

Natural matter has always been our passion.

Our fathers, grandfathers and great grandfathers took the same impassioned approach when they shaped our splendid surrounds - our place of birth and homeland, our local area and country. Following in their footsteps, we apply ourselves to the task with love, dedication and reverence because this matter is alive and possesses a soul. It acts as an extraordinary source of inspiration for our Natuzzi Italia collections. The beauty of matter is brought to the fore in endless combinations of form and color, artfully defined by the Natuzzi Style Center and tirelessly studied in a quest for perfect harmony: leather and fabrics are carefully counterpointed by unfinished wood and glossy lacquered surfaces, superlative marbles contrast with hardened steel and the warmth of natural wood is set off by glass and metal with a shiny or satiny surface. This unique heritage translates into a vast range of immense worth. A country of marvels to be explored together with our interior designers in the Natuzzi Italia stores as your "place of harmony".



The pleasure of leather.

Natuzzi and leather have always gone hand in hand. This natural affinity has been part and parcel of the success of the Natuzzi collections since the very beginning. Imitated in vain by our competitors, Natuzzi leather is a benchmark for the industry and recognised for its superiority all over the world. Its beauty, suppleness, colour and even its scent have raised the bar in terms of visual elegance and pleasure for the senses. Being a living material, leather literally breathes. And it does not feel the need to disguise its natural markings. As a matter of fact, it puts them on proud display, proffering them as incontrovertible proof of its authenticity. At Natuzzi, this kind of worn leather forged by nature is (aptly) called Natural. It is a source of pride for our experienced master tanners who enhance each detail with consummate skill, relying on an exclusive tanning process developed over the course of 60 years. The leather is not only beautiful to look at, it has also been processed to meet European environmental standards which are amongst the most stringent in the world. This is why it offers a guarantee of complete non-toxicity and durability over time. But the advantages don't stop here. To cope with the many challenges of daily life, you can count on the practical nature of Protecta leathers - the ultimate way to enjoy sofa lounging without worries. An invisible protective layer makes them incredibly hardwearing whilst preserving all their natural beauty. Which ensures total peace of mind while children and pets get on with doing what they do.

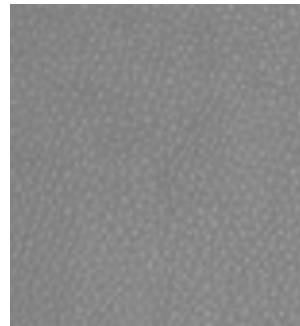

Essential

The ultimate choice for lovers of leather and its undeniable allure. Not only does this material withstand the test of time, it actually looks better as the years roll by. A wide array that is bound to satisfy the whole gamut of style and usage requirements.

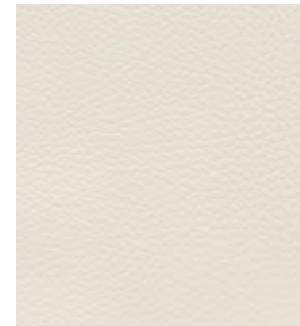

Stylish

A selection marked by a strong focus on style. With fashionable hues and innovative designs, it explores inspirations and trends coming from all over the world. A perfect way to elevate your sofa with grit and personality.

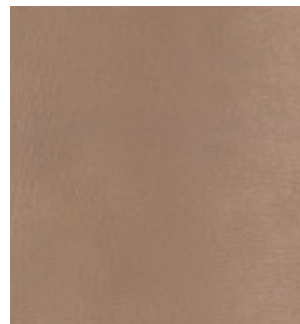

Prestige

Leathers made for customers who want exclusive coverings and timeless elegance. They embody all that Natuzzi stands for not only in terms of quality.



Fabrics and microfibres. The “Natuzzi touch”.

That it is a Natuzzi fabric is immediately apparent from its touch. It is such a delight to the senses that it is almost impossible not to stroke it. The vast choice available means that everyone will be able to find the covering best suited to their home and lifestyle. Motifs and precious patterning are etched on linen, wool, silk and cotton which entice with their natural allure. Viscose, velvet and microfibre astound with their tactile texture while ensuring immense resistance to both washing and wear and tear. A world where the quality of natural materials goes hand in hand with the innovative nature of hi-tech fibres and outperforming fabrics enhanced with exclusive technology which coats each fibre with an invisible film, locking out dirt and allowing for the easy removal of stains. Fabrics which are safe, ecological and OEKO-TEX® Standard 100 certified, meaning that they boast an international guarantee of total fibre-and-textile-product sustainability. Fabrics designed to help you enjoy life – and your sofa – together and without a care.



Smart

Fabrics that will suit any setting, whether it is classic or modern, and which have a huge colour palette that is easy to match and practical to use.

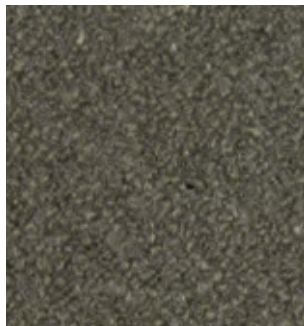

Premium

A top-of-the-line premier-quality edit for the most discerning customers. Ageless fabrics that bring to the fore the beauty of the products, imbuing their surrounds with an exclusive aura.



Trendy

Natuzzi Italia seeks out new fashion and design trends from all over the globe and puts its own spin on them. New sophisticated bold patterns come into being, expressing instantly recognisable, personal and spirited décor styles.



Performance

Natuzzi believes that comfort means enjoying life without having to worry. This is why we have developed a range of innovative fabrics that allow you to easily wipe away stains, using just water and mild soap. Our exclusive technology coats each fibre with an invisible molecular film which locks dirt out. A shield that not only makes the fabric stainproof, scratchproof, tearproof and antistatic, it also makes sure that the environment is respected (there being no PFCs or perfluorocarbons). The Performance fabrics are the innovative part of the Natuzzi coverings catalogue. They retain all the beauty and durability of the original, yet have a more practical surface for cleaning which also repels fur. So, dogs, cats and children can do their worst and you have no need to fear.

- **Water-and stain-resistant**
- **Washable with just water**
- **Greater resistance and durability**
- **Protection from mites & bacteria**
- **NO PFCs (Perfluorocarbons)**
- **Pet hair-resistant**



Discover the practical nature of Performance fabrics

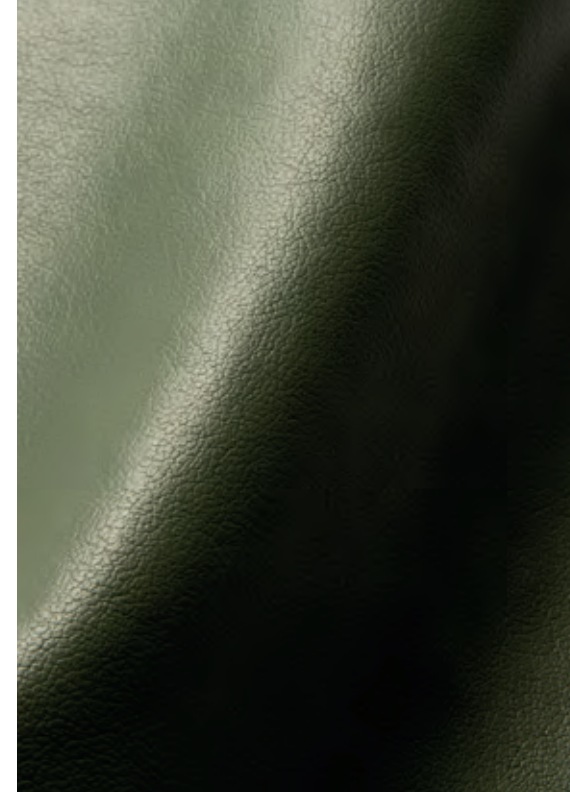

Natuzzi Eco-Fiber Collection. Another step forward for the Planet.

Craftsmanship and innovation, driven by uniqueness. Made from bio-based and recycled materials, our Eco-Fiber Coverings Collection is a step towards a more responsible future. A milestone on Natuzzi’s sustainability journey. Made from plants, paper, boiled wool, recycled materials, to reduce the impact on the environment. Made with passion, a powerful sense of responsibility and our in-depth knowledge of technology to make these eco-fibers at a level of quality that is on a par with everything else we produce.



ByBorre®

An innovative 100% eco-friendly 3D™ fabric, exclusively created for Natuzzi Italia by the Dutch textile innovation studio BYBORRE. In addition to being aesthetically striking and exceptionally comfortable, with a surprising materiality, the fabric stands the test of time.

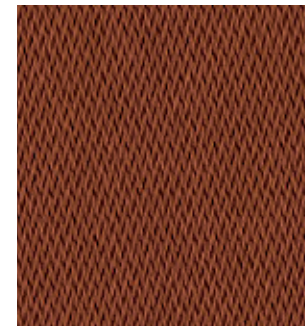

Origami

A fabric composed mainly of paper fibers – an environmentally friendly and 100% natural sustainable product – combined on the back with a chenille fabric with a honeycomb weave. Natural and durable, with the feel of linen but with a more pastel effect. Origami fabric has inherent flame-retardant qualities due to the paper that does not burn, but quickly turns to ash.



Vello.

Our exclusive ecofriendly fabric strongly connected with the culture and territory of Puglia: simply sheep’s wool, made from 50% wool and 50% acrylic yarn. An incomparable design and a natural feel that only nature itself can provide. The fleece is not treated other than washed.



Gaia

Unlike fossil fuel-based alternatives, Gaia uses content that is organic, plant-derived sources. A result achieved by-and GMO-free grain and other food products supported by textile substrates of natural origin or recycled materials. All raw materials are guaranteed by specific certifications, such as FSC-certified viscose that comes from sustainably managed forests. Other ingredients are added to be sure that the new material achieves the required standard of quality and aesthetics.



Wood. Beauty in our neck of the wood(s).

For wood too, superlative quality standards stem from fine workmanship and stringent controls right across the production chain. Skilled cabinetwork (a jewel in the crown of Italian design from Gio Ponti onwards) reaches a pinnacle in the Natuzzi Italia collections which offer a broad array of finishes with exquisite detailing, but also extends to more modern furnishing styles. The timeless elegance of natural wood meets the edgy zeitgeist of lacquered wooden surfaces. Tables, chairs, sideboards and bookcases are not only versatile, but emanate warmth and are delightfully tactile. So that the chicest houses in the world can showcase a material whose beauty will never wane.



Marble. The preciousness of Nature.

The marbles used for Natuzzi furnishings reflect the natural and ancient beauty of precious and elegant materials. Each vein and imperfection tells of this beauty. Quality, design and high aesthetic value meet in our products, breathing life into real masterpieces. From the rich colour and dense texture of Dark Emperador to the black beauty of Nero Marquina with its white-and-grey veins, the luxurious and sophisticated Travertino and the Marmo di Carrara chosen by Michelangelo for sculpting his masterpieces, all our marbles perfectly encapsulate our philosophy and commitment to make objects that last. And our designers use these stones to striking effect with exquisite contemporary flair, making sure that our products are instantly recognisable and in a league of their own.

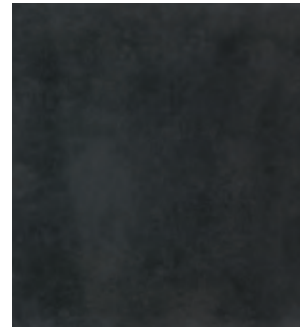

Black Absolute / Black Granite
It is one of the darkest varieties of natural stone on earth. The dark-tone black Granite is called Absolute Black Granite. Granite is mostly used for external flooring, wall cladding, counter tops and vanity tops. Stone of African origin (Zimbabwe). Our tops have a matte and brushed finish achieved with specific diamond brushes. The surface has been enhanced with a final water-repellent treatment.



Antigua Green Marble
This marble has a green background with white veins and occasional nuancing that tends towards yellow. This stone features fairly regular patterning. Green Antigua Marble is a kind of green marble quarried in Iran. It's also called Antigua Green Marble, Persian Green Marble, Green Antigua Persia Marble, Iran Antique Green Marble, Green Persia Marble, Classic Green Marble or just Green. The Antigua Green Marble used for our products has a matte brushed finish. The surface has been enhanced with a final water-repellent treatment.

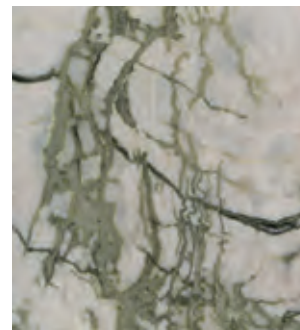

Glossy Calacatta Green
Calacatta Green is a precious marble with a white background and veining in a various shades of green. There is marked unevenness in the distribution of the veins. Slabs can have bold veining on some parts and be clear on others, making for a distinctive irregular appearance. It is of Asian origin and is specially processed in Italy. Being a marble of the sedimentary sandstone category, it also contains various types of crystals and grey stones distributed in a non-homogeneous way; these must be considered to be one of the qualities of this kind of marble. The top surface is glossy. The surface has been enhanced with a final water-repellent treatment.



Matte Antique Pink Marble
Antique Pink Marble is a limestone with a brecciated appearance and uneven beige or light-green clusters embedded in an antique-pink matrix, hence its name. Of Italian origin, this beautiful stone comes in a host of different shades. Antique Pink marble commonly has whitish veins which are sometimes quite thick, giving it a painterly appearance. On a historical note, Pink Antique Marble has often been used for architectural work on private villas and churches throughout Italy and magnificent instances can be found in many ancient homes.



Glossy Lilac Marble
White lilac marble comes from Turkey and due to its distinctive veined appearance and natural beauty, it is suitable for elegant interiors. It has bold veining and a colour variation that ranges from purple to black. Some slabs may have beige nuancing within. The top surface is glossy. The surface has been enhanced with a final water-repellent treatment.

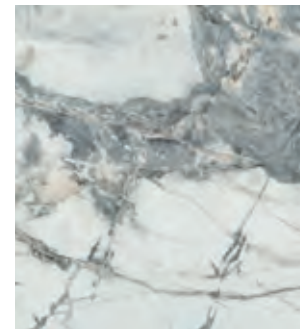

Invisible Grey
Marble of Italian origin. Like a piece of abstract art, Invisible Grey stone has impactful inimitable patterning that looks as if an inkpot has been shattered across a pure white slab. It ushers a sense of harmony and cohesiveness into your home. The eye is irresistibly drawn to trace the delicate dark-grey lines contrasted against the pure white background, and, as it does, the spirit is uplifted. A superb addition to any setting, the dramatic beauty of Invisible grey reverberates with power and will provide a perfect backdrop to meaningful memories.

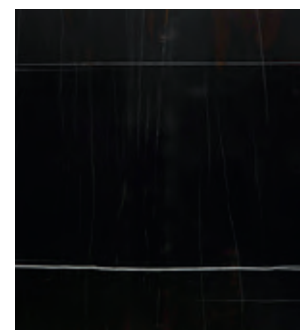

Sahara Noir
Sahara Noir is one of the most elegant marbles around. The black background with gold-and-white veins make Sahara Noir ideal for luxurious environments. Marble is formed through a metamorphosis process of sedimentary rocks. Its multiple colours stem from the presence of different minerals that overlap each other to perfection, creating shades and veins that have embellished houses and buildings of all periods and styles for centuries.

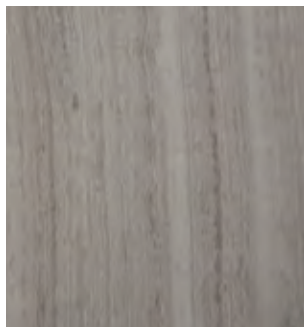

Athens Silver Cream
Athens Silver Cream is a neutral stone that is anything but plain. This attractive light-cream marble is characterised by a threadlike striated patterning that is delicate, yet distinguishing. Allows for flexible design choices.

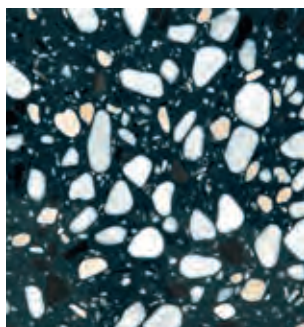

Stardust Terrazzo Stone
Is an agglomerate composed of a precious mix of marble and resin grits that are carefully selected and customised for colour and size specifically for Natuzzi. The material is then finished and smoothed. It stands apart for its skilful blend of large pieces of marble and tiny stones with an iridescent appearance for a modern exclusive feel. The edges of the top are finished with a curved bevel. This material has an extraordinary resistance to abrasion and an even colouring. A top in STARDUST-Terrazzo Stone brings to mind "A Venetian Terrace", something which the whole world recognises as being artistically and culturally superlative and representative of the area of Venice and Italian manufacturing in general. The combination of different colours and materials means that all aesthetic needs can be met, including the most modern ones.



Fossena Stone
It is a limestone of North-African origin quarried in Tunisia. It is a stone with a compact and homogeneous background that is grey/brown in colour. This material stands out for its minimalist appearance, enhanced by a homogeneous and uniform structure. Flitting rust-coloured shadows and subtle ivory veins enliven the surface of the Fossena stone. The presence of some white salt or dark spots are another feature of this material. Fossena grey limestone is a sedimentary stone of marine origin and consists almost exclusively of the mineral called calcite. Small quantities may also contain dolomite, quartz and other clay minerals. These mineral or organic additives give limestone a heterogeneous colouring.



Travertine Titanium
Titanium Travertine is a special variant of the more classic travertines. Originating from Iran, it has an astoundingly attractive brown colour that can verge on various nuances of grey. This material is increasingly used in modern-looking settings and often combined with steel and concrete. Travertine belongs to the limestone family and is a sedimentary stone of continental origin. Travertine is a mono-mineral rock, meaning a rock composed of a single mineral. Its main component is calcite. It may also contain clay minerals, haematite, limonite and quartz. For this reason it can take on different colour variations. As it is quite soft, it is easy to work with and particularly suitable for interiors.



Fossena Stone
Bio-Malta (Bio-Mortar) is a coating consisting of a single-component mortar in an aqueous emulsion and natural fillers such as quartz, marble, recycled glass, terracotta powder and mother of pearl. It is a bio-compatible and eco-sustainable finish which is also odourless, non-toxic, stain-proof, non-slip and easy to maintain. It is applied entirely manually. This gives it a clearly artisanal look and an exclusive refined appearance. Highly specialised craftsmen work with care and skill on every single piece, guaranteeing outstanding quality standards.



Natuzzi comfort

Comfort is one of Natuzzi Italia's most prime concerns and the tenets of its philosophy and lifestyle approach hinge upon it. Padding provides the greatest guarantee of comfort. It must give the body support, achieving the right balance of plumpness, softness and bounciness, yet also keep its shape over time, so that everyone can enjoy a quality lounging experience even years down the line. This is the reason why Natuzzi Italia carefully selects and combines its padding materials; they are subjected to tests which mimic day-to-day usage and wear-and-tear on typical parts, such as the backrest, seat cushions, headrest, armrests and cushions.

Special Fillings

Polyurethane

Polyurethane is a rubber with several important features: it is non-allergenic, anti-bacterial, flexible and hard-wearing. Our Natuzzi polyurethane is manufactured without using freon or other potentially toxic agents.

Shape memory foam

This is a polyurethane which changes shape according to the weight it bears. What this means is that it adapts to the body, offering supreme levels of comfort.

Climalight

Anatomical, breathable and totally non-allergenic, this innovative material is a special blend of polyester microfibres which gives a plush "down-like" effect.

Down

Natuzzi's goose down filling is Class 1 (UNI EN 12934/01): non-allergenic and flame-retardant, it has undergone a variety of different sterilisation, enhancement and washing treatments which are a guarantee of the utmost hygiene.

**Quality System
Certification according
to ISO 9001 standards**



A certified commitment.
Natuzzi was one of the first companies in the furnishing industry to set in motion a certification process with the major universally-recognised certifying bodies. Still today, its commitment is real and ongoing.

It ensures that quality procedures are compliant with international standards and the end customers' expectations. It is the best-known international standard and an opportunity for Natuzzi to preserve and improve a Management System which takes into account all corporate processes so as to ensure the optimisation of resources, reduce production costs, achieve set targets and maintain constant quality levels that will raise overall customer satisfaction.

**ISO 14001
Environment Certification**



It certifies that the impact of manufacturing activities on the environment is constantly checked. More specifically, it relates to the design and creation of prototypes by setting up projects for wood processing, sewing, assembling and bonding operations. This certification is indispensable if we are to guarantee high levels of sustainability.

**OHSAS 18001 –
Safety on the workplace**



It sets forth the terms of our commitment to the safety and health of our workers on the workplace. Developed by the British Standards Institution, it is an international benchmark and a vital yardstick for Natuzzi which strives for constant improvement in the management of its human resources, being, as it is, aware that people drive success and are an invaluable part of the system.

**FSC®
Forests and timber**



This guarantees that the timber used for manufacturing purposes has been sourced from responsibly managed forests and that the social, economic and environmental needs of current and future generations have been respected. The Forest Stewardship Council certification was awarded to Natuzzi by the Bureau Veritas certifying body.

**Ergocert Ergonomic
Certification**



“Human-Centred Design” certification attests that the ergonomic requirements assessed by Ergocert (the leading European Certifying body for Ergonomics) have been respected. The guidelines regulating Human-Centred Design guarantee that the whole design and production process takes into consideration the needs of the final user and offers an experience of unparalleled comfort.

technical specifications

seating	692	sofas
	754	sofa beds
	756	re-vive
	760	armchairs
	781	ottomans and benches
	786	chairs
bed	793	beds
furnishings	799	coffee tables
	813	tables
	820	desks
	824	bookcases
	826	bar cabinet
	827	sideboards
	831	bedroom furnishings
décor	836	rugs
	842	lamps
	848	mirrors
	851	blankets and cushions
	853	accessories
857	room fragrances	



by Marcel Wanders studio
Sectional sofa available in linear and corner versions. Adam, thanks to its extreme versatility, satisfies every need for space and comfort. Upholstered sofa sides with hidden, removable hooks.

Coverings
It can be ordered in fabric, Gaia, Byborre or leather from cat. 15 Le Mans. 3242 orderable with honey-colored solid ash wood base ft55. V242 orderable with powder-coated metal base available in two colors: ft 79 matte black and ft 73 matte terracotta.

Base
The solid wood or metal base and piping along the entire profile of the sofa enrich and emphasize the design of the model.



Padding
Microcellular polyurethane foam padding made from a plant based raw material, drawing from renewable sources found in nature. Such padding meets the demands of a market that is increasingly sensitive to products with a low environmental impact and ensures maximum comfort, thanks to high production technology and the high quality of the raw materials from which it is made. The seat is composed of polyurethane foam with density 50 combined with a layer of memory foam 2 cm high.

Relax functions
Multi-position adjustable headrest with hidden snap mechanism. Multi-position adjustable armrest with snap mechanism when opened and friction when closed. The function of armrest and headrest, the wide and generous seats invite you to enjoy maximum comfort.

available versions

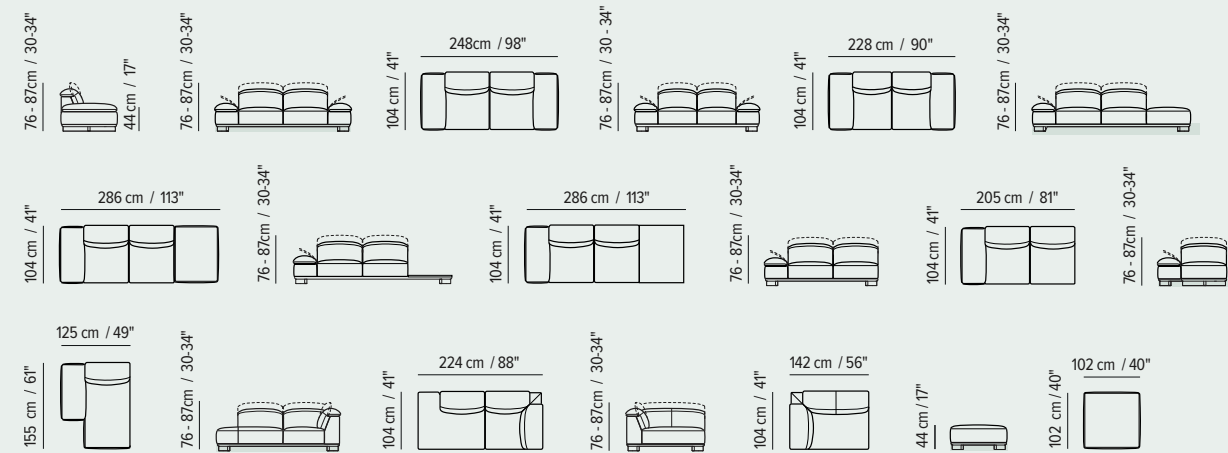

composition examples

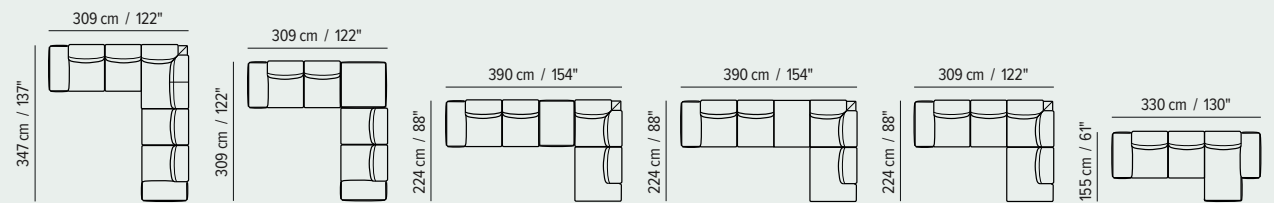



by Bernhardt&Vella
Amalia is an invitingly warm and welcoming nest, ideal for relaxation. A sofa with rounded lines, but also an armchair and an inviting dormeuse. Amalia is also available without armrests, a perfect solution both in a living room and in a sleeping area.

Padding
Its original rounded backrest embraces two large cushions filled with high-density polyurethane foam and Climalight padding and Climalight padding which helps to improve comfort, while making it look invitingly soft and reassuring. Available in over 200 colours, the upholstery comes in fabric or exquisite Natuzzi leather.

The front feet are slightly higher than the back ones:

feet height
11.0/26.0 cm | 4.3/10.2"

Feet available in wooden finishes
- smoked oak
- European walnut

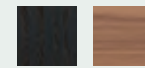

available versions



by Formafantasma
Available in linear and corner configuration with terminal seat - Apulo was born to accommodate even small multifunctional objects designed for the most sophisticated home office needs. Like a wooden desk to hook onto the back of the frame, which allows you to have a worktop and a height-adjustable side table that amplifies the functionality of the project with an additional support surface. The comfort of the home office-inspired project is joined by a cable duct in the sofa structure to allow the electrical cables, of a laptop for example, to be incorporated seamlessly into the sofa.

Frame
Metal frame with elastic straps that guarantee the same comfort for every seat and more lasting support.

Coverings
- with code 3231 it is possible to order the model in mix: back and lateral panels in saddle leather; seat cushions, back cushions and arms in Byborre, fabric or leather (starting from cat. 25 Status).
- with code V231 it is possible to order the model all in leather (starting from cat.25 Status).

available versions

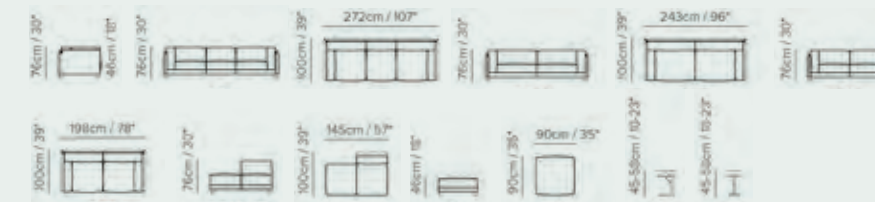

composition examples

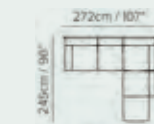



by Paola Navone

Available as a 2- or 3-seater, or in the swivel-base armchair version. The softness of its shape is accentuated by two gigantic clips sinking into and grasping the backrest – traversing it to shoulder height – and culminating in a bow detail at the back with a pop/glam vibe.

Padding

Mixture of premier-quality fillings: certified polyurethane, 4 cm of Memory Foam and Climalight - a special filling that reproduces all the fluffiness and supreme comfort of down.

Coverings

Available with a leather or fabric covering, or with the BYBORRE covering designed by the Dutch textile-innovation studio BYBORRE, using a yarn that combines premium-quality wool and PES.

Concealed feet in scratchproof metal.

available versions



by Natuzzi Design Center

Sofa available in linear and corner versions. Two different seat widths that let you choose the one best suited to your needs.

Relax functions

Adjustable headrest on each seat, including corner seats, to satisfy all comfort requirements. Built-in lumbar cushions for excellent lower-back support. Soft Touch system available on each seat, controlled by a button located between the seat and the armrest: a single touch activates the recliner function, opening the seat, backrest and footrest. Watch TV comfortably even when lying down. The Zero Wall space-saving system means the recliner function works without the need to move the sofa away from the back wall.

Additional options

Audio system with built-in, bluetooth-enabled speakers (available on 3-seater and recliner-function sofas). The armrest features refined leather details that can either match the colour of the fabric or contrast with it.

Coverings

Coverings in fabric or Natuzzi leather, available in over 200 colours.

Feet height
4.0 cm | 1.6"

feet available in wood finishes

- walnut
- wengé

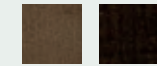

available versions

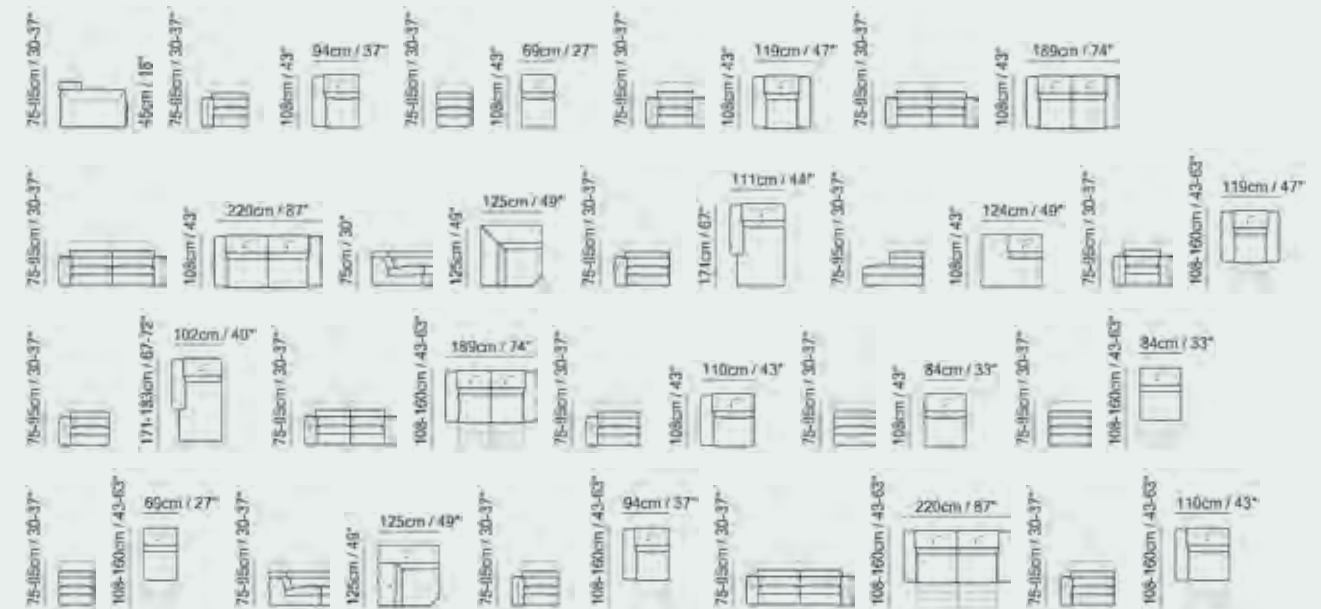

composition examples



block

page 44, 47



by Sabine Marcelis
Block sofa introduces an unprecedented dimension of comfort that puts the sofa and those who live it at the center: a soft sculpture, the absolute protagonist of the environment that hosts it.

Coverings
Upholstered in fabric or leather starting from cat. 25 Status.

Wooden base in natural bamboo.

Easy-to-move thanks to the wheels at the front of the base. Under the seat there are elastic straps which guarantee the same comfort for every seat and long-lasting support.



available versions



bolder

page 52, 55



by Natuzzi Design Center
Modular sofa available in the linear and corner versions, with and without recliner function. The large abacus allows the creation of countless configurations suitable for all needs and spaces, thus adapting to the new demands of contemporary lifestyle.

Coverings
Upholstered in fabric or leather starting from cat. 15 Le Mans.

Relax functions
Dual power mechanism available: 4 buttons with independent functionality for headrest and footrest. Reclining function can be activated separately on each seat.

Feet height
4,5 cm | 1.8"

available versions



composition examples

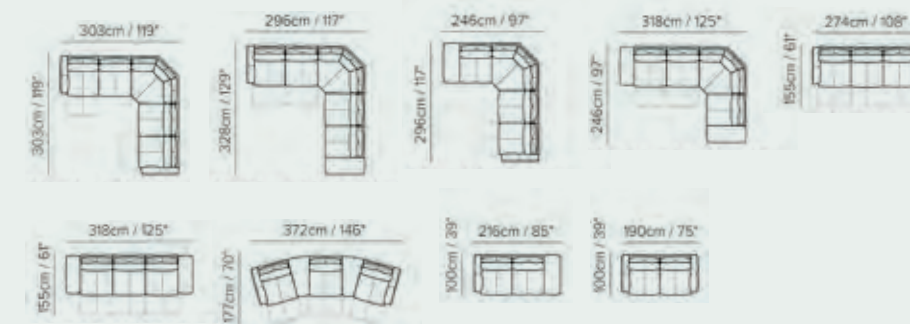

borghese

pages 397, 394



by Natuzzi Design Center

Sofa available in the linear and corner versions, with and without chaise longue. The leather version comes with zigzag stitching that further elevates the sofa and enhances its artisanal beauty. Available with a solid-wood or metal base.

Coverings

Upholstered in fabric or premium Natuzzi leather.

Padding

The mix of polyurethane and memory-foam padding guarantees comfort, support, and a look that remains unchanged over time.

Relax functions

Adjustable headrests on every seat to satisfy specific comfort requirements.

Feet height
16.0 cm | 6.3"

Feet available in wood finish
- wengé



available versions

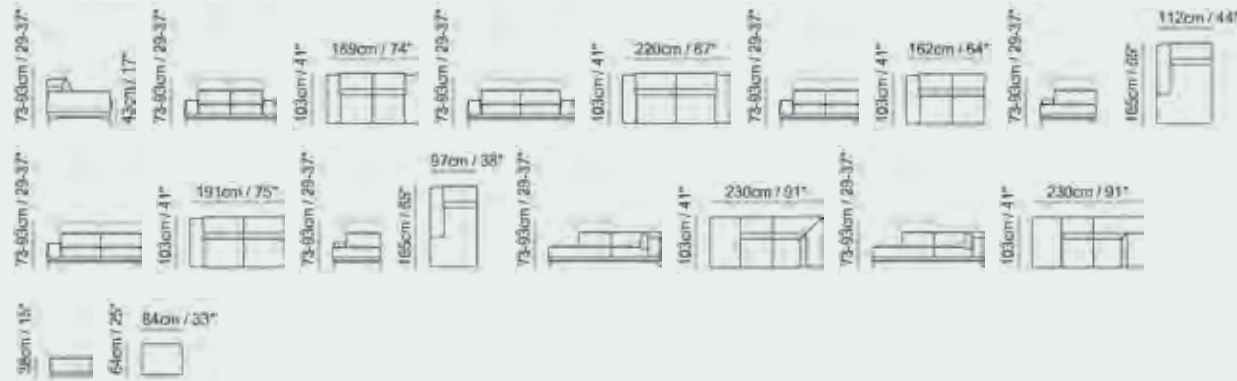

composition examples

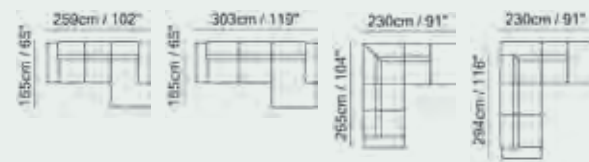

botanic

pages 350, 352



by Claudio Bellini

A welcoming refuge which adds style and originality to your interiors. Botanic reinterprets the style of the 50s, harmonising it in an open-based project with a metal base, clear features of later trends. Compact and elegant, it is ideal for home interiors or inviting public rooms.

Coverings

In fabric or leather, it generates an immediate sense of cosiness and hospitality, thanks to its soft and enveloping forms.

Frame and feet height
22.0/20.0 cm | 8.7/7.9"

Feet available in metal finish
- matte black



available versions



brio

pages 460, 462



by Natuzzi Design Center

Sofa available in the linear and corner versions, with and without chaise longue. The side quilting on the leather version and refined stitching on the armrests and cushions enhance the beauty of its design and silhouette. The edges with raised stitching elevate it further.

Relax functions

Adjustable headrests on every seat (except on corner ones) to satisfy individual comfort requirements. Also available with the Audio System activated via Bluetooth with incorporated speakers. Soft-Touch mechanism available on each seat: a touch activates the recliner function by simultaneously opening the seat, backrest, and footrest. The recliner function can also be manual (activated via a lever) and is also available on the chaise longue. The Zero Wall space-saver system activates the recliner function without having to detach the sofa from the wall behind it.

Padding

The mixture of polyurethane and memory-foam padding guarantees remarkable comfort with a structure and look that remain unchanged over time.

Coverings

Upholstered in fabric or premium Natuzzi leather.

Hidden feet height

3.0 cm | 1.2"

available versions

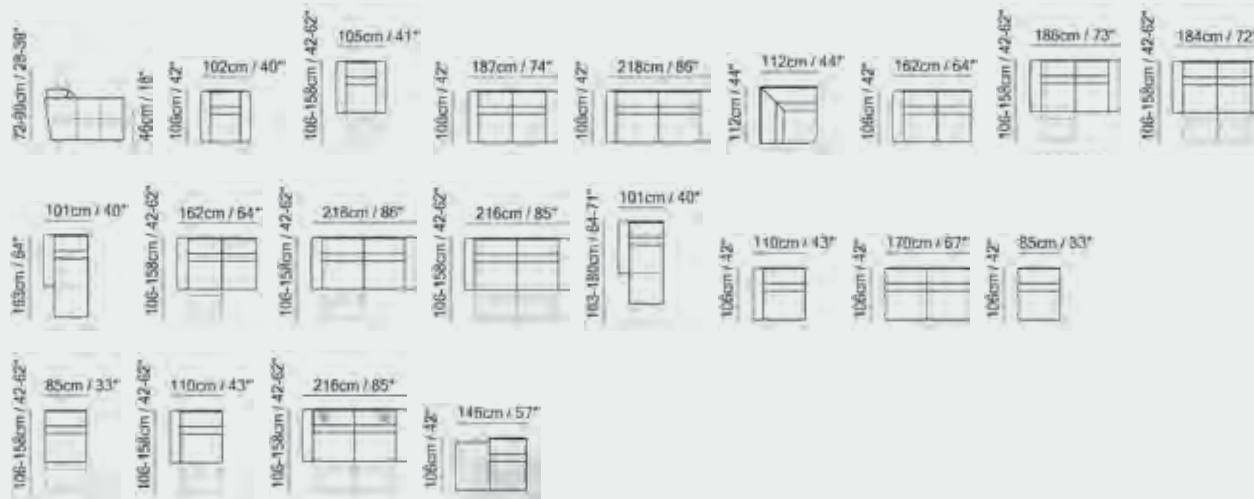

composition examples



buddie

pages 148, 149, 156, 160



by Mauro Lipparini

A host of corner or in-line arrangements with or without chaise-longue.

Padding

Seat cushions and backrest in high-density polyurethane which guarantees perfect moisture regulation, ideal warmth control, first-class pressure relief and high elasticity.

Coverings

Available in fabric, leather and with the BYBORRE covering designed by the Dutch textile-innovation studio BYBORRE, using a yarn that combines premium-quality wool and recycled PES and comes in a choice of five different colours.

Concealed feet in black non-slip metal.

available versions



composition examples

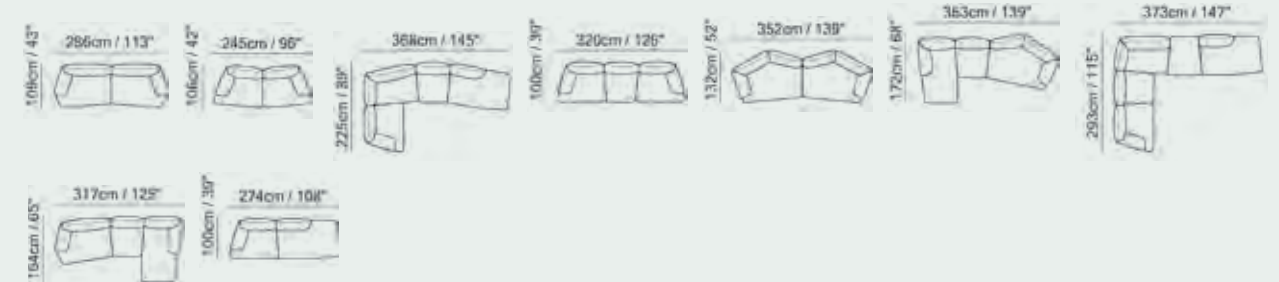



by Elena Salmistraro

Compact sofa, with round and welcoming shapes that are well suited to smaller environments without sacrificing absolute comfort. The external frame, sinuous and enveloping, is made up of a single frame in plywood that is beautiful to be seen also from the back. A cozy shell to escape and relax in. Available in linear configurations with and without recliner function.

Coverings

Upholstered in a wide range of high quality fabrics and leathers. Available entirely in fabric or all in leather from category 15 Le Mans or in a leather-fabric mix including Byborre.

Padding

Precious padding, all certified, guarantee a look and support that don't change over time. Seat and back cushions in high density polyurethane (35).

Relax functions

are activated by two buttons located in the inside of the armrest: the front button activates the opening of the footrest, the rear button activates its closing. The headrest is equipped with a manual mechanism that allows it to be lifted to different heights. In addition, it can be rotated forward and backward to reach the desired comfort.

Hidden feet

in black metal with anti-scratch and non-slip rubber pads. Height 4cm.



available versions

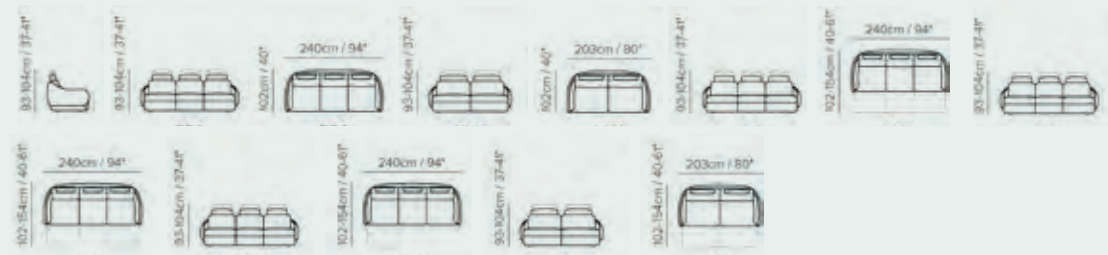

by Mauro Lipparini

Campus is perfect for any living room space with its modular elements which will help you create the right combination for your space and furnishing requirements.

Since seats are upholstered on all sides they can be placed separately throughout the house. The slip cover underneath the seat elements prevents them from slipping out of position.

The Campus system also features tables, a sideboard, and a dining table and chairs.

Padding

The blend of exquisite high-density polyurethane foam and Climalight padding, using special anti-allergy, breathable materials, ensures lasting good looks and support.

Coverings

Available in leather or in removable fabric. Unusually, the inside of the arm- and backrest are in suede, while the main frame is upholstered with irregular weaves available in 7 colours.

Feet height

11.0 cm | 4.3"

Metal Feet available in two finishes

- glossy champagne
- matte black with anti-scratch foot liners



available versions

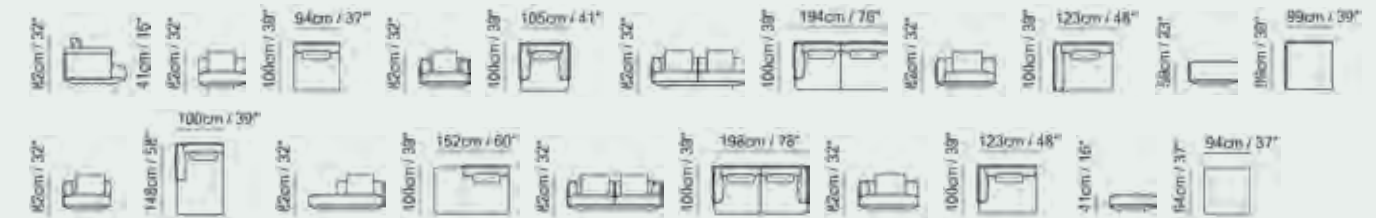

composition examples

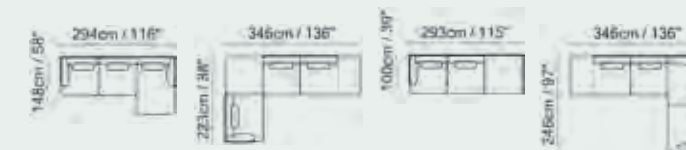



by Mauro Lipparini

Perfect for any living-room space, with its modular elements which can be positioned at will (even independently) as they are upholstered on each side. Its decorative profile and solid-wood base are design details which place this sofa firmly at the heart of any space it is used in. Cava can be used to create an almost infinite number of compositions in a mixture of leather and fabric seat modules, with various different mechanisms in the same combination. The sofa can be customised by combining the upholstered seats with wooden table tops in various different shapes and sizes.

Padding

The seat cushions have all of the comfort and quality of polyurethane and Memory-Foam padding, which ensure that its good looks and support are long-lasting.

Relax functions

Each module will have one of two mechanisms available - a manual flip mechanism moves the backrest from a vertical to a horizontal position, while the electric sliding mechanism moves the back and armrest back and forth.

The seats are supported by a tubular solid-wood base in a ash-wood tobacco-brown finish combined with a metal coffee finish (with anti-scratch foot liners).



available versions

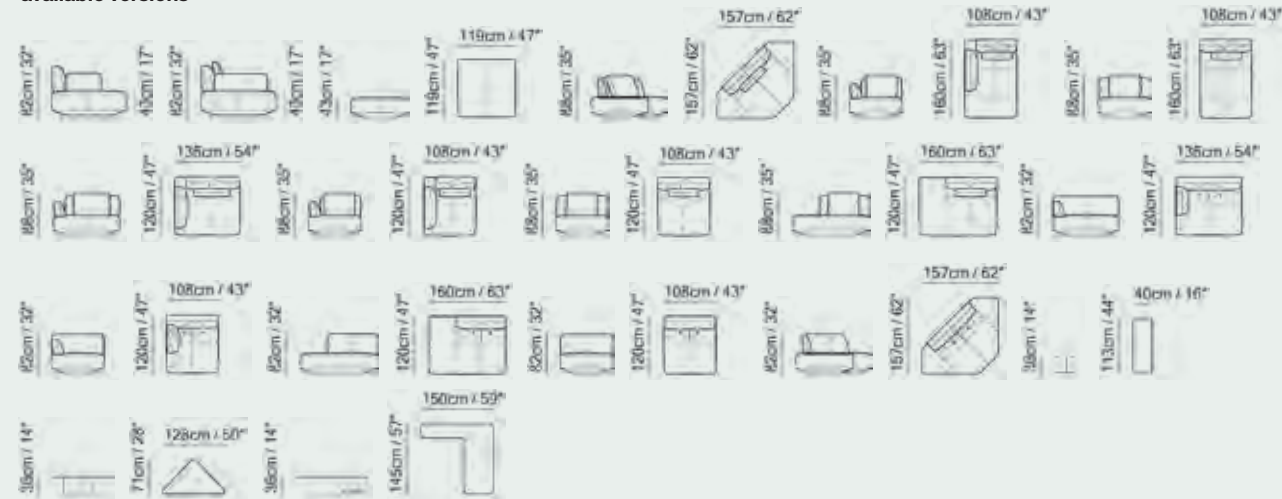

composition examples

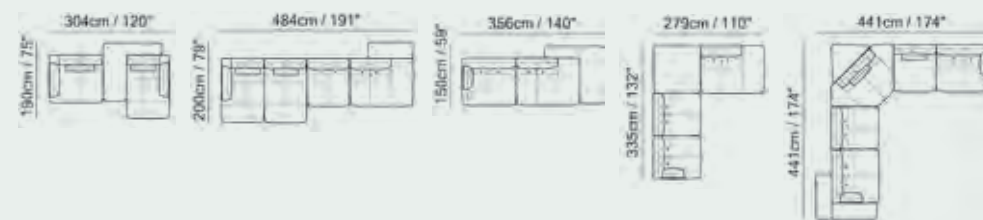

by Mauro Lipparini

A totally modular sofa, available in in-line and corner versions and with or without a relax function, to satisfy every space and style need. Each seat element, with the exception of those equipped with the relax function, is upholstered on each side so it can also be used individually.

Relax functions

Triple-Motion function available on each seat: three independent motors allow you to adjust the position of the headrest, backrest and footrest as desired. The Zero Wall space-saving system activates the relax function without the need to move the sofa away from the wall behind.

Additional options

The composition can also be equipped with free-standing panels to create more intimate, cosy corners and to divide the rooms of the house. The model is highly customisable: you can combine different seat elements upholstered in leather and fabric. It can be integrated with open storage units that serve as an armrest or shelf.

Padding

The mixture of padding in polyurethane, Memory Foam and 100% goose down provides support and a look that remains unchanged over time.

Coverings

Available in over 200 colours, the wide range of coverings comes in fabric and fine Natuzzi leather. In the version with the real leather body, the sofa is always upholstered in fabric.

Hidden no-scratch and non-slip metal feet.

available versions

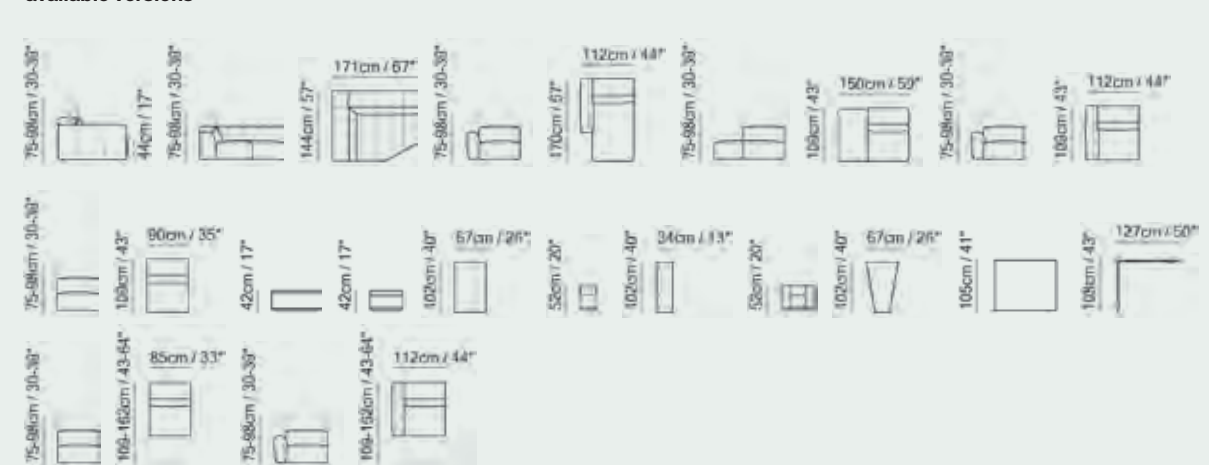

composition examples





by Nika Zupanc

Option of in-line and corner arrangements with or without chaise longue (modular seat units with removable fixings). Having been covered on every side, the seat units can be used on their own and in various areas of the house. Low-slung base with hidden feet in black metal tipped with scratchproof rubber bumpers.

Padding

The fillings for the seat cushions and backrest come in high-density polyurethane and in Memory Foam.

Coverings

Coverings available in a wide range of fabrics and leather (which can also be combined).

Feet height

3 cm | 1.2"

available versions

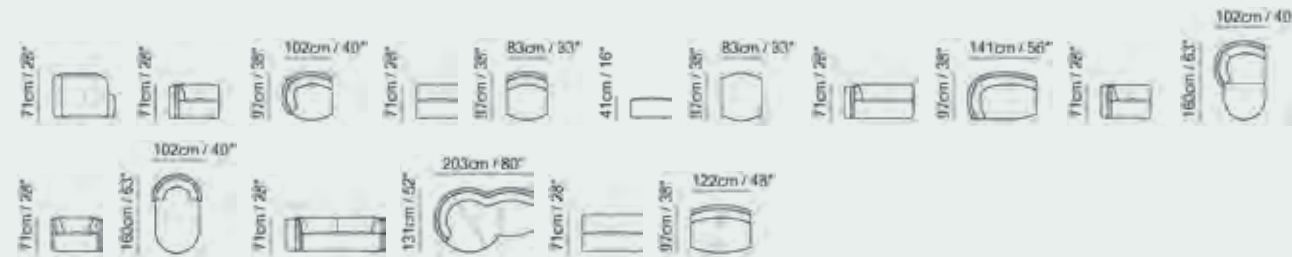

composition examples

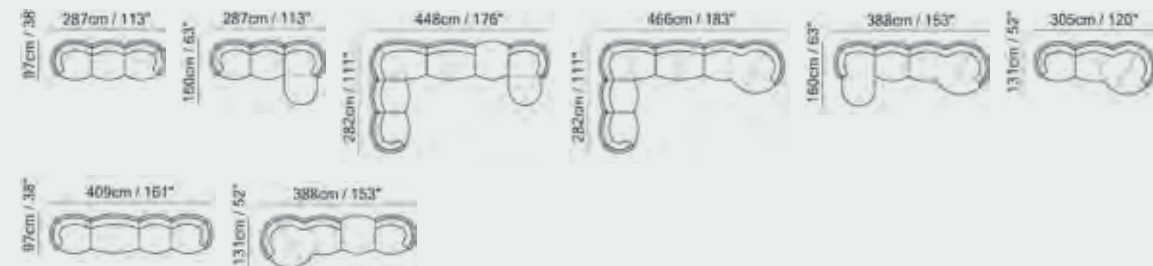

by Natuzzi Design Center

Sofa bed available in the linear and corner versions, with and without chaise-lounge. Recliner features, bed and chaise-lounge with storage space available for all compositions. Anti-bacterial and anti-allergy Greenplus mattress.

Relax functions

Adjustable headrest on every seat, except the corner seats. Soft-Touch mechanism available on each seat: a touch activates the recliner function by simultaneously opening the seat, backrest, and footrest. The recliner feature can also be operated manually (with a lever).

Additional options

Both a contrasting and matching trim are available.

Coverings

Upholstered in fabric or premium Natuzzi leather.

Feet height

4.5 cm | 1.8"

Feet available in wood finishes

- walnut
- wengé

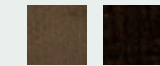

available versions



composition examples





by Maurizio Manzoni

Modular system that allows for a host of corner or in-line arrangements with or without chaise-longue. Each seat cushion has been embellished on the front and at the back with a tubular hexagonal-section foot in steel, available different finishes. The base has undergone a polishing and powder-coating process. The special coating serves both a protective and decorative purpose, guaranteeing a highly scratchproof, exceptionally durable and easy-to-clean surface.

Padding

The backrest cushions have been padded entirely in 100% sterilised goose down. The filling comes in high-density polyurethane and 100% goose down encased in separate chambers.

Coverings

Dominio is available in a wide range of fabrics and leather.

Feet height

5 cm | 2"

Feet available in

matte black or shiny silver



available versions



composition examples

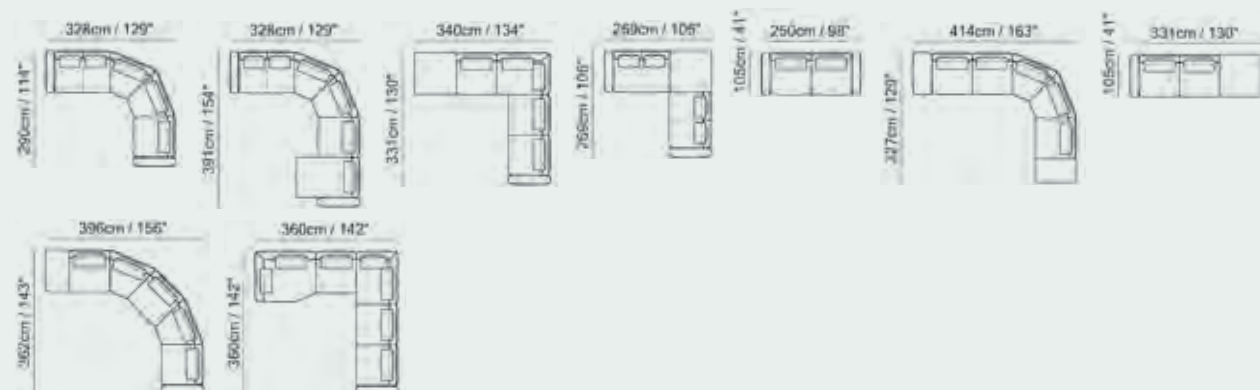

by Claudio Bellini

Sofa available in three-seater or two-seater versions. The absence of seams and stitching on the seat cushions and the backrest is synonymous with the clean simplicity of the shape.

Additional options

The optional trim along the armrests and seat cushions is also available in contrasting colours to emphasise the flowing lines of the sofa.

Padding

The mixture of polyurethane and Memory-Foam padding guarantees extraordinary comfort, support and lasting good looks. The padded feather lumbar cushions offer more relaxing comfort.

Coverings

Upholstered in fabric or premium Natuzzi leather.

Feet height

12.5 cm | 4.9"

Feet available in metal finishes

- glossy chromed
- black chrome



available versions



dorian

pages 236, 239



by Manzoni&Tapinassi

Sofa available in the linear and corner versions. The model's high modularity makes it suited to any space. The individual seat modules, finished in every part, can also be used on their own. The non-slip and scratchproof concealed metal feet guarantee stability and protection for the floor.

Additional options

The model is also available with raw-edge stitching when lined with premium Cassidy leather (thick and natural) or with the innovative Manopesca fabric.

Padding

The mixture of polyurethane, memory foam and feather padding guarantees comfort, support, and a look that remain unchanged over time.

Coverings

Upholstered in fabric or premium Natuzzi thick leather.

Feet height

3.0 cm | 1.2"

available versions



composition examples



duca

pages 413



by Natuzzi Design Center

Sofa available in the linear versions. The hand-stitched details on the sides and cushions imbue it with a prestigious feel. The tall metal feet make it easier to clean under the sofa.

Relax functions

Soft-Touch mechanism available on each seat: a touch activates the recliner function by simultaneously opening the seat, backrest, and footrest. The Zero Wall space-saver system which activates the recliner function without having to detach the sofa from the wall behind it. Adjustable headrest on every seat and hidden storage compartment inside the wide armrest.

Additional options

Optional Audio System with built-in speakers which can be activated with a USB device or Bluetooth, AUX and iOS.

Padding

The mixture of polyurethane and memory-foam padding guarantees remarkable comfort with a structure and look that remain unchanged over time.

Coverings

Upholstered in fabric or premium Natuzzi leather.

Feet height

13.0 cm | 3.1"

Feet available in metal finishes

- glossy chromed
- black chrome

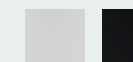

available versions

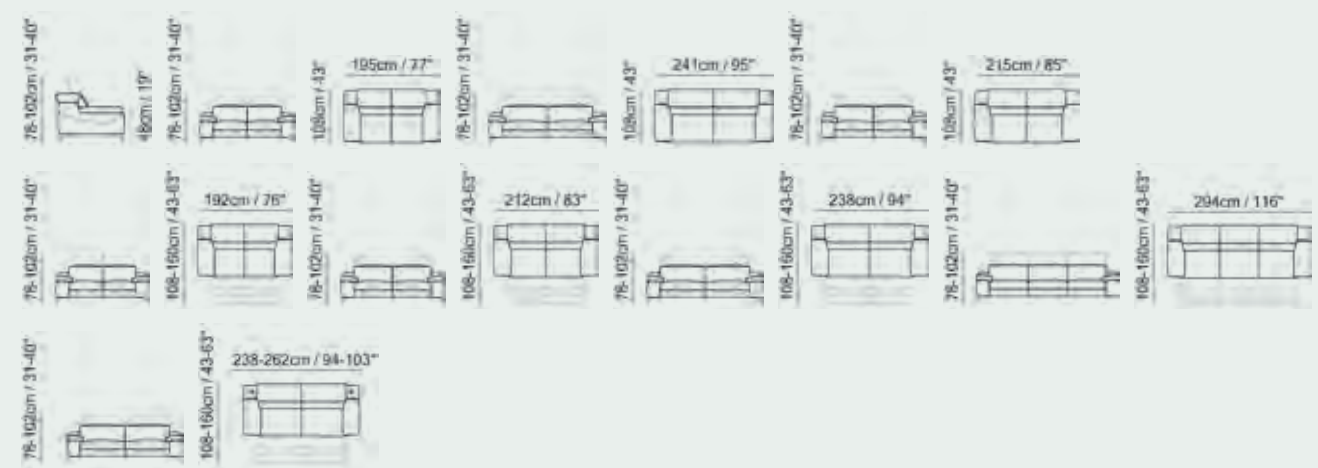

estro

pages 264, 282, 385



by Natuzzi Design Center
Compact sofa with generous, comfortable seating. Aesthetic details include the thin border around the entire sofa, punctuated by its metal feet.

Coverings
Coverings in fabric or Natuzzi leather, available in over 200 colours.

Feet height
21.0 cm | 8.3"

Feet available in metal finishes
- glossy chromed
- black chrome



available versions



euforia

page 58, 60



by Marcel Wanders Studio
Modular sofa available in the linear and corner versions, with and without chaise-longue. Elegant, urban size model to answer the increasing need for smaller sofas to fit reduced apartment sizes in urban areas, without renouncing to a handcrafted high end product, rich of precious details.

Coverings
Upholstered in fabric or leather starting from cat. 25 Status. Available also in Byborre.

Padding
Extremely comfortable seat cushions thanks to a new polyurethane foam with high density (50). It is a brand new microcellular polyurethane foam, based on vegetable raw materials from natural renewable resources. An innovative product with a low environmental impact - it guarantees high level of air permeability, optimal elasticity and supreme comfort.

available versions

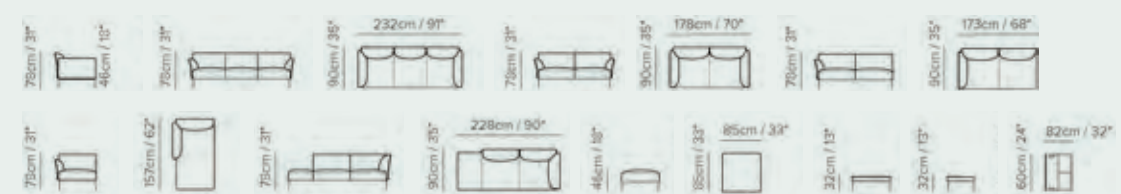

composition examples





by Manzoni&Tapinassi

The raised or open-cut stitching reveals the quality of Natuzzi's authentic Italian craftsmanship and extensive experience in working leather.

Relax functions

Sofa with recliner function activated separately on each seat. Available with Soft-Touch mechanism: a touch activates the recliner function by simultaneously opening the seat, backrest, and footrest. The system is also available with rechargeable battery (to avoid the unpleasant effect of the visible power cables when the sofa is placed in the centre of the room). The model is also available with the Zero Wall space-saver system which activates the recliner function without having to detach the sofa from the wall behind it.

Padding

The mixture of expanded polyurethane and memory-foam padding guarantees enhanced comfort, durability, and a look that remains unchanged over time.

Coverings

Upholstered in premium Natuzzi leather.

Feet height
11.0 cm | 4.3"

Feet available in metal finishes
- glazed nickel
- black chrome



available versions



by Natuzzi Design Center

Fly is available in in-line versions, with or without a chaise-longue. The triangular metal feet lend the model lightness, elegance and originality.

Relax functions

An innovative mechanism allows you to adjust the depth of the seat with a simple gesture for personalised comfort.

Feet height
12.0 cm | 4.7"

Feet available in metal finishes
- glazed nickel
- glossy chromed



Coverings

The Fly sofa is available in a wide range of coverings in fabric and in fine Natuzzi leather, in over 200 colours.

available versions



composition examples





by Natuzzi Design Center

Galaxy lives up to its name with a galaxy of versatile design elements with linear and corner versions, suited to every space and lifestyle. You can choose seats that are smaller or larger, depending on your space and comfort requirements. The model offers the utmost in terms of versatility and comfort and you can choose from:

- a version with recliner mechanism that can be activated separately on each seat, headrest and footrest. The headrest has a dual function: it can be raised to provide enhanced comfort for taller people and reclined forwards manually to achieve the desired position while watching TV or reading a book.
- version with height-adjustable headrest
- version without recliner mechanism.

A corner version may include all the different options described.

Relax functions

The Zero Wall space-saver system enables the recliner mechanism to be activated without having to pull the sofa away from the wall.

Coverings

Galaxy's linear design can be upholstered in high-quality Natuzzi leather or fabric. This model has an exquisite leather insert on the armrest.

Feet height

4.0 cm | 1.6"

available versions

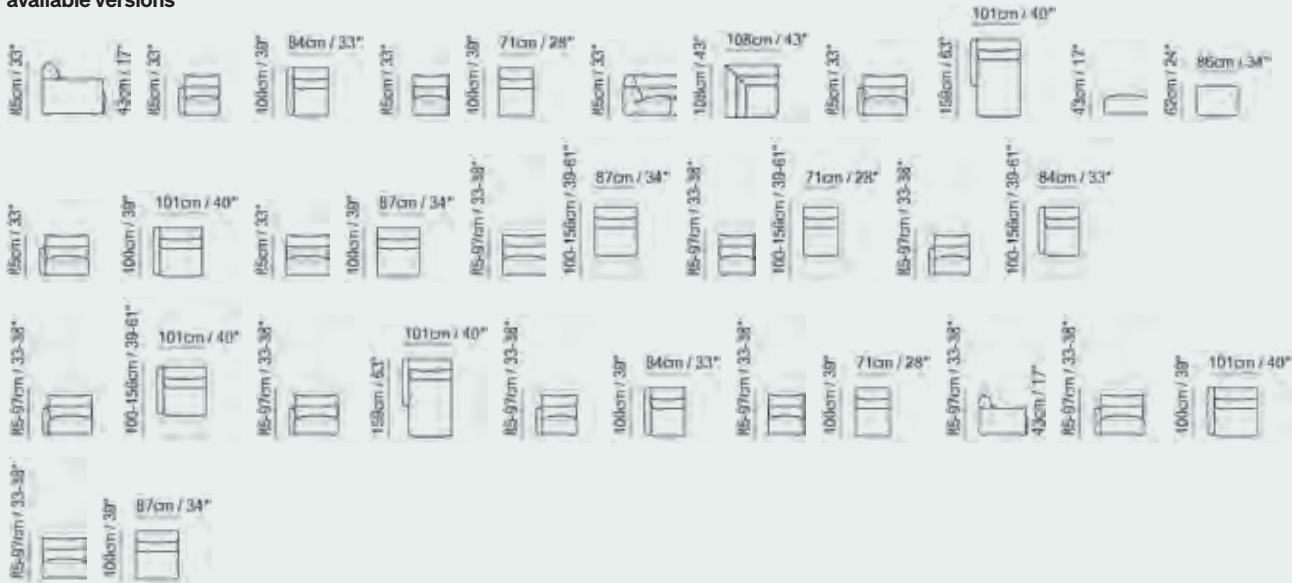

available versions



by Manzoni&Tapinassi

The Herman system includes in-line and corner sofas, with or without a chaise longue, as well as ottomans, benches and tables with a metal base. Each module is finished on all sides and can also be used as a standalone piece. Thanks to its extreme modularity, Herman allows for reusing the same elements over time by changing their position or using them on their own, adding a dynamic and original dimension. Side armrests in two different heights: flush with the backrest or lower down depending on how the sofa is used.

Additional options

The matching or contrasting grosgrain insert further enhances the design and customises the sofa. Optional cushion with adjustable movements to achieve the desired comfort level.

Feet height

4.5 cm | 1.8"

Metal spine available in metal finishes

- pewter
- glazed bronze



Coverings

Upholstered in fabric or premium Natuzzi leather.

Padding

The mixture of expanded polyurethane, memory foam and Climlight padding guarantees remarkable comfort, with a structure and look that remain unchanged over time.

available versions

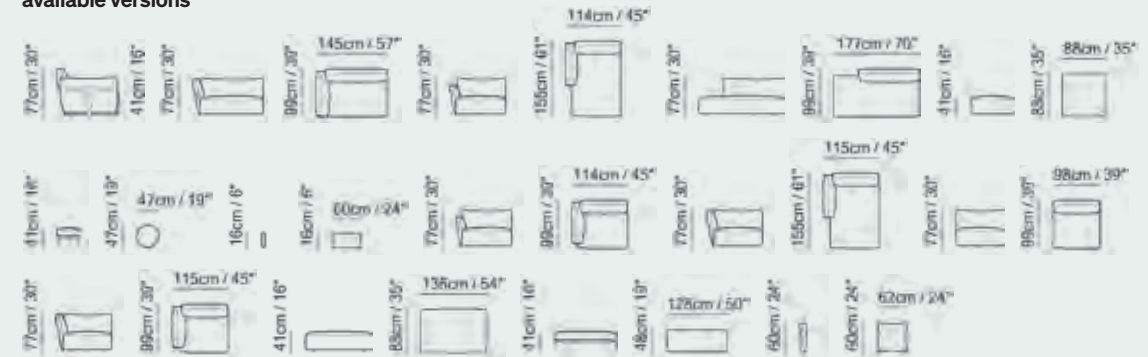

available versions

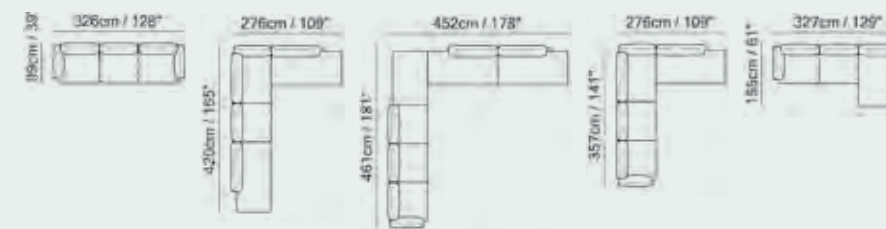



by Natuzzi Design Center

Sofa available in the linear and corner versions, with and without recliner function. The pinched seam detailing on the armrests and back cushions usher in a prestigious aura. Non-slip scuff-proof metal feet so you can move the sofa around without worrying.

Coverings

Upholstered in fabric or premium Natuzzi leather.

Padding

The mixture of polyurethane and memory-foam padding guarantees remarkable comfort with a structure and look that remain unchanged over time.

Relax functions

Soft-Touch mechanism available on each seat: a touch activates the recliner function by simultaneously opening the seat, backrest, and footrest. The relax system is also available with a rechargeable battery (to avoid the unpleasant effect of visible power cables when the sofa is placed in the centre of the room). Zero Wall space-saver system which activates the recliner function without having to detach the sofa from the wall behind it.

Feet height

5.0 cm | 2"

available versions

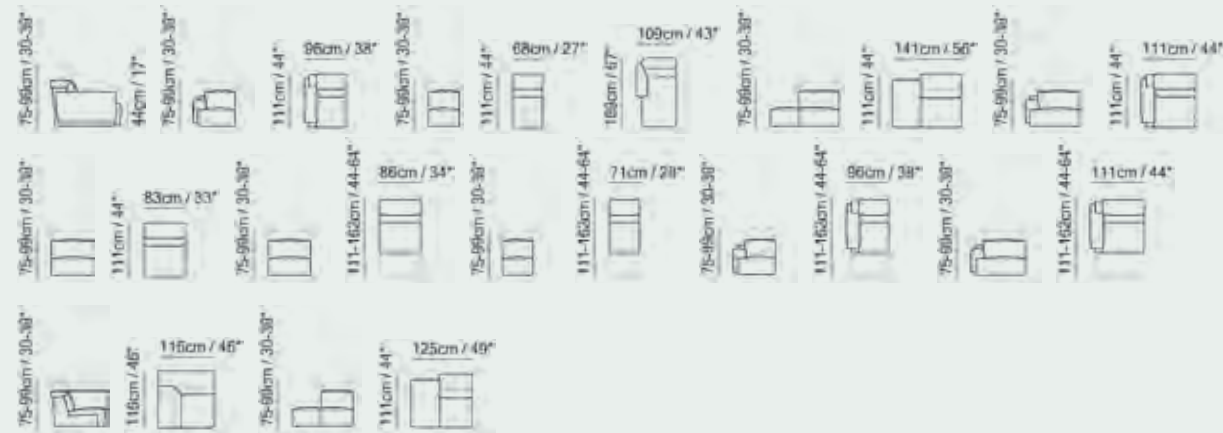

composition examples

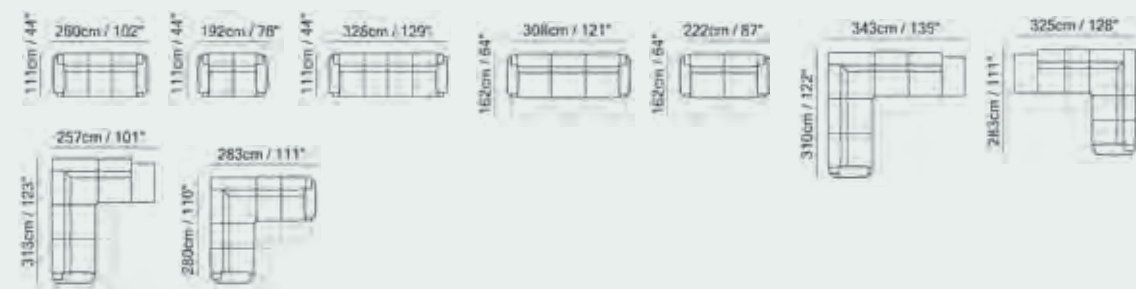

by Michele Menescardi

A modular sofa, available in in-line and corner versions, with or without a chaise-longue, to satisfy every space and style need. The model is highly customisable: you can combine different seat elements upholstered in leather and fabric. Each seat element is upholstered on all sides so it can also be used individually. The decorative trim along the profile of every seat highlights the sofa's particularly enveloping design. The black chrome-metal base is equipped with non-slip and anti-scratch rubber pads, ideal for the most delicate floors.

Coverings

Available in over 200 colours, the wide range of coverings comes in fabric and fine Natuzzi leather. The leather version is enhanced with vertical quilting over the entire sofa.

Padding

The mixture of padding in high-quality polyurethane and Climalight, a special breathable and hypo-allergenic silicone microfibre, provides support and a look that remains unchanged over time.

Hidden no-scratch and non-slip metal feet.

available versions



composition examples

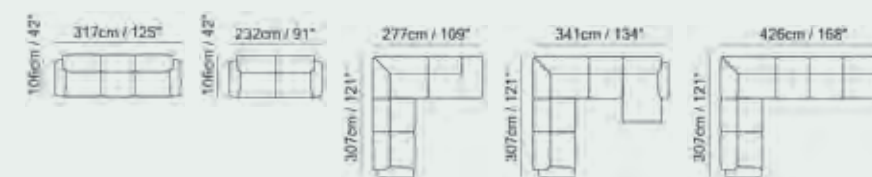

infinito pages 284, 282



by Marcantonio

Perfect as a centrepiece or as a corner seat, Infinito underlines on the one hand the strong propensity for innovation, which is typical of the brand, and on the other, it highlights the great know-how of Natuzzi craftsmen and their ability to develop complex projects with high added value.

Padding

The metal structure combined with different densities of polyurethane gives the sofa its unmistakably dream-like shape. Filling in elastic polyurethane of various densities.

Coverings

Available with the BYBORRE covering designed by the Dutch textile-innovation studio BYBORRE, using a yarn that combines premium-quality wool and recycled PES and comes in 5 different colours.

Non-slip feet concealed by the structure

available versions

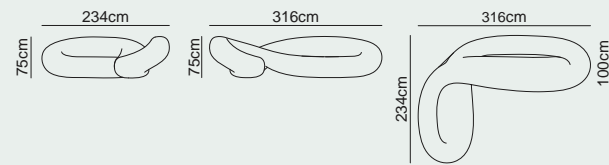

jeremy pages 404, 407



by Manzoni&Tapinassi

Sofa available in in-line, corner, and armchair versions. The premium materials reflect the quality associated with Natuzzi.

Padding

The mixture of polyurethane, memory foam and feather padding guarantees comfort, support and a look that remain unchanged over time.

Coverings

Upholstered in fabric or premium Natuzzi leather.

Feet height
17.0 cm | 6.7"

Feet available in metal finish
- pewter



available versions



composition examples



juno

pages 62, 64, 67



by Massimo Iosa Ghini

Linear sofa available in the two-seater and three-seater. A hymn to maximum visual comfort, with its cozy and generous dimensions, its soft and enveloping look - harmoniously contrasted by the rigid wings that define the lines of the armrests and backrest.

Coverings

Upholstered in fabric or leather starting from cat. 25 Status.

Padding

Internal structure in molded polyurethane.

Production process:

1. Polyurethane resin shape.
2. Inside the mold there is a metal structure that acts as the backbone of the sofa.
3. Afterwards the high-density polyurethane (50) is injected into the mold.
4. After a specific period of time, this shape stiffens and becomes the body of the sofa.
5. This structure is bonded with a layer of transformed lower density polyurethane to give softness to the seat, to the back and armrests.
6. Everything is covered with dacron, leather or fabric.
7. The end result is a comfort, design and support unchanged over time

Hidden metal feet

kendo

pages 116, 199, 126, 128

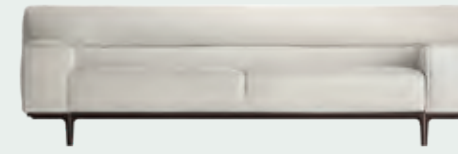

by Manzoni&Tapinassi

A modular sofa that provides any living area with outstanding comfort, timeless beauty and a refinement expressed through exquisite details. Every element of the sofa is fully upholstered on all sides and can also be used as a standalone piece.

Available in linear and corner compositions, with or without chaise-longue, Kendo adapts perfectly to any space and any style of décor.

Padding

The mixture of polyurethane foam and Climalight guarantees enduring comfort and looks over time.

Coverings

Upholstered in fabric or fine Natuzzi leather. This model is also available in thickened leather, a covering that enhances its silhouette. The solid wooden base has a metal insert, a distinguishing feature of the collection.

Feet height
14.0 cm | 5.5"

Feet available in wooden finishes

- smoked oak with metal insert in brass
- olive walnut; with a metal insert in a pewter tone

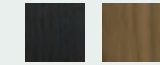

available versions



available versions

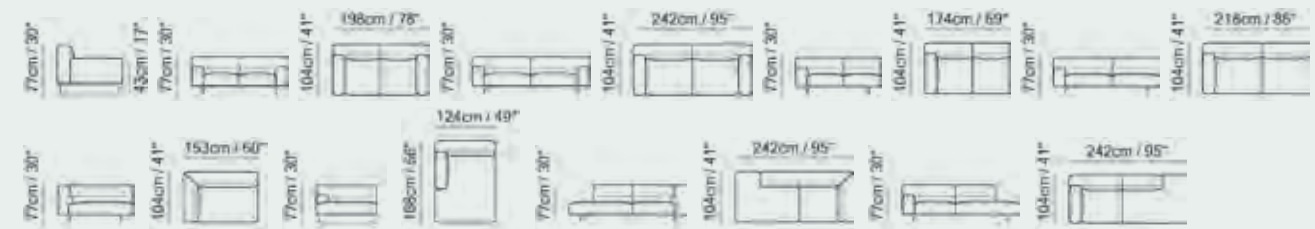

composition examples

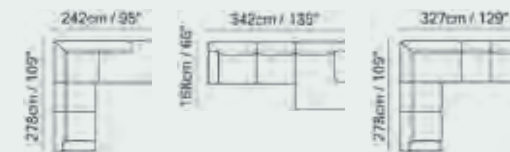

king

pages 330, 333



by Natuzzi Design Center

King is available in in-line versions with 2 or 3 seats and in an armchair version. The precious capitonné workmanship on the backrest and armrests expresses unparalleled craftsmanship. Wooden feet, in various finishes, support the cosy seats. coverings The King sofa is available in a wide range of fine Natuzzi leather coverings in over 80 colours.

Feet height
6.5 cm | 2.4"

Feet available in wood finishes
- walnut
- wengé



available versions

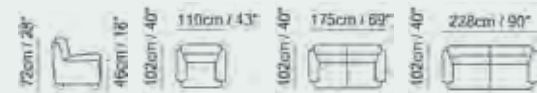

la scala

pages 180, 183



by Claudio Bellini

A modern take on the Chesterfield sofa with incredibly deep, comfortable armrests and frame. Exquisite quilting and the skilful hand-buttoning of the backrest and arms are an expression of the virtuoso craftsmanship which characterises the upholstery. From a linear sofa, La Scala can be transformed into a modular system by adding modules that create a customisable informal Chesterfield for a contemporary living-room solution. Also available as a dormeuse or chaise longue. Hand-stitched buttons in leather or fabric, paired with the chosen upholstery.

Padding

The mixture of polyurethane and state-of-the-art silicone-treated microfibre padding guarantees excellent comfort, support and lasting good looks.

Coverings

Upholstery in fabric or exquisite Natuzzi leather.

Feet height
12.5 cm | 4.9"

Feet available in metal finish
- black chrome



available versions

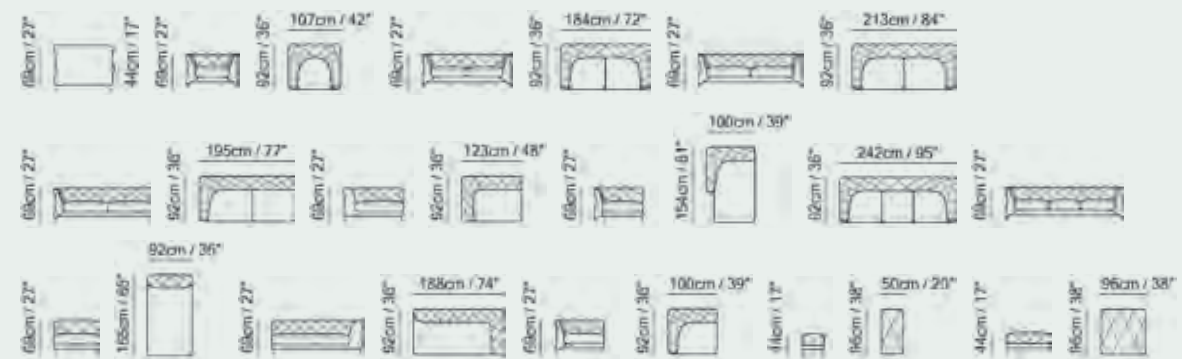

composition examples

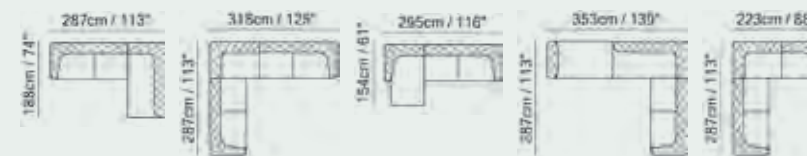

leaf

pages 262, 264



by Maurizio Manzoni

Leaf stands apart for its extreme versatility. It features a cushioned back for a comfortable and customisable look. Clean-cut lines and generous proportions are embellished by piping which runs along the sofa profile, making it suitable for all furnishing styles. Comfort and linearity blissfully converge, embracing everyday moments of conviviality and well-being. Each side of the product is finished, making the model versatile and freely combinable.

Padding

Exceptional comfort is guaranteed by the upholstery: in addition to polyurethane, Climalite and fine materials are perfect for unbeatable relaxation.

Coverings

The Leaf sofa is available in a wide range of fabric and fine Natuzzi leather covers.

Feet height

10.5 cm | 4.1"

Solid wood base in black ash wood combined with metal feet in glossy black



available versions

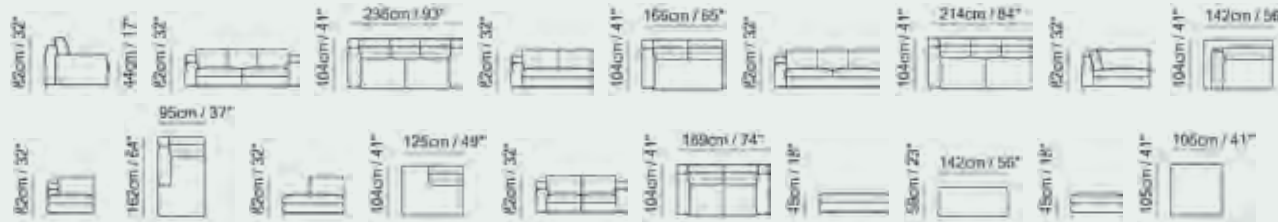

composition examples

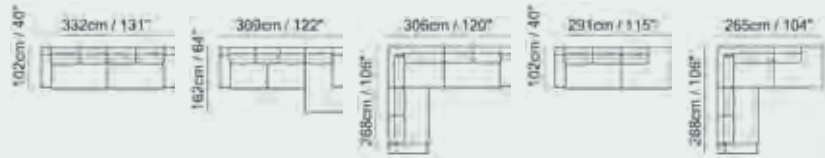

leuca

pages 466



by Natuzzi Design Center

Encounters are the leitmotif of the Leuca sofa. The headboard and seat are skilfully and originally intersected and set on conical brushed metal feet. Playfully harmonic geometries and alternating shapes characterise this compact and gritty-looking piece without compromising on comfort which is guaranteed by large cushions on the back.

Coverings

Leuca is available in leather and fabric.

Feet height

18.0 cm | 7.1"

Feet available in

glazed nickel



available versions



levante

page 486, 488



by Mauro Lipparini

Compact and open-based, Levante is a sofa with a strong personality, available in two/three-seater and armchair configurations. It stands on metal feet which confer lightness and geometric stability upon the project. Vertical stitching structures the headboard and seat, positioned parallel to elegant armrests. The discontinued sides under the armrests add a touch of uniqueness. A stylish whim which confers lightness upon the project. Practicality and design: the ideal furnishing item for adding class to urban interiors.

Coverings

Levante is available in leather and fabric.

Feet height

13 cm | 5.1"

available versions

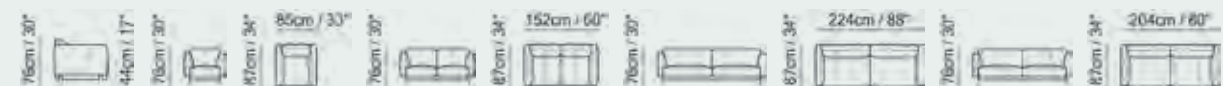

long beach

pages 171, 176



by Claudio Bellini

Sofa available in the linear and corner versions, with and without chaise longue. Large proportions and refined details underline the model's high manufacturing quality. Sides and cushions finished with refined relief trims: an aesthetic detail that underlines the model's sophisticated yet artisanal look.

Coverings

Upholstered in removable fabric or premium Natuzzi leather.

Padding

The mixture of polyurethane, memory foam, and feather padding guarantees remarkable comfort, with a structure and look that remain unchanged over time. Seat with backrest cushions in two different sizes padded with soft goose down.

Metal feet adjustable to two different heights.

Feet height

6.0 / 9.0 cm | 2.4 / 3.5"

Feet available in
matte black metal



available versions

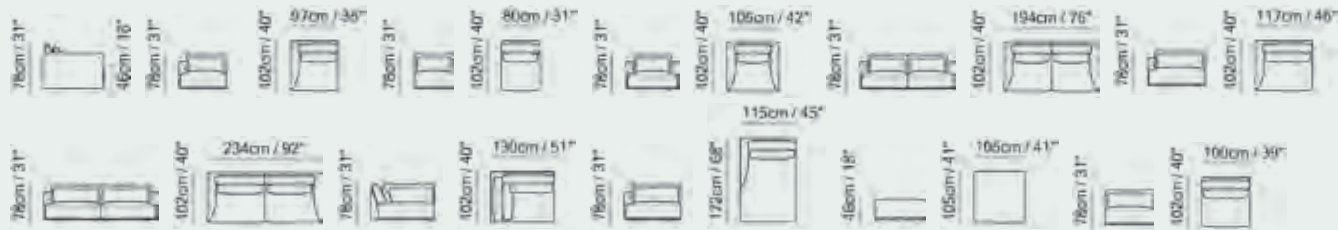

composition examples

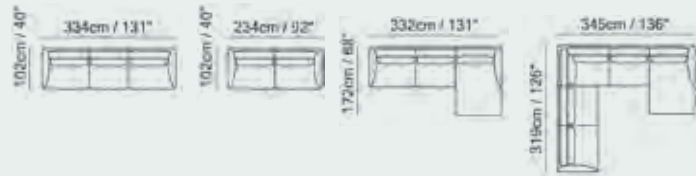

melpot

pages 184, 187, 648



by Mauro Lipparini

Melpot is a symbol of modularity taken to its logical conclusion, making it the star of living spaces of any size. All the individual elements are interchangeable and can be repositioned as desired, or used singly. Ottomans, drawers, bookcase components and surfaces extend the versatility of the Melpot system, available in every linear and corner configuration, with or without chaise-longue.

A mini collection of cushions in different colours, materials and sizes with different functions elevates the model's pared-back silhouette and enhances comfort levels.

Coverings

With over 200 colours to choose from, the range of fabrics or fine Natuzzi leather coverings allows for personalisation according to your tastes and requirements. Some items are available in quilted leather and fabric.

Feet height

6.0 cm | 2.4"

available versions

modules



quilted modules



modules with low armrest

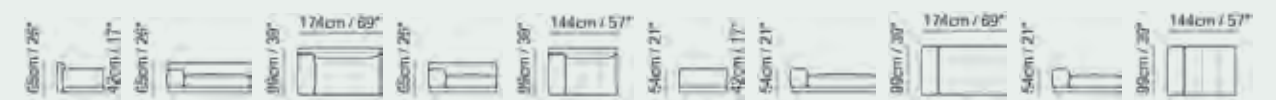

ottomans



cushions



drawer - bridge table



bookshelves

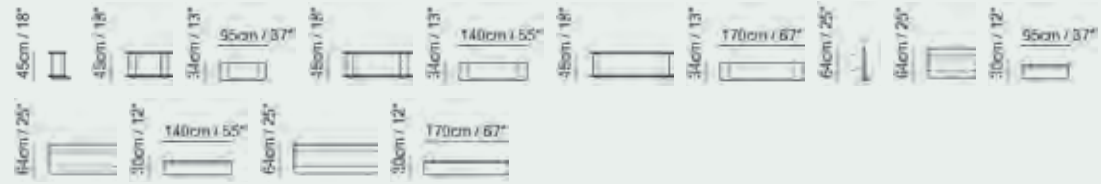

composition examples



new classic pages 340, 343, 345



by Fabio Novembre
Modular system featuring separate and completely finished seat units that can also be used as standalone pieces. Side units fitted with full-length feet in tubular metal.

Padding
A certified polyurethane filling is a warranty of respect for the environment, well-being and health for consumers and quality that withstands the passage of time.

Coverings
Available in leather or fabric, the sofa also has the option of a double covering in a combination of two materials with a fabric part for the backrest/armrests and a leather one for the frame and seats. The versions with armrests are embellished with a tubular metal foot that runs along the entire side of the seat.

They are available in two finishes:
- matte black
- glossy silver



available versions

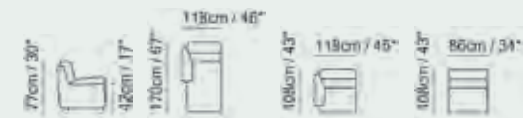

composition examples





by Maurizio Manzoni

A modular system made up of various units which can also be used as standalone pieces because each one has been covered and finished on all sides. A round sleek silhouette for the armrest-backrest embellished with a tubular-metal detail which girdles it like a belt, accentuating its sumptuously soft and lushly rotund body. In addition to being a startlingly attractive design element, the tubular-metal detail serves as a foot, rooted in steel laser-cut slabs.

Additional options

Optional cushions also with different coverings and in different colours to the sofa.

Padding

Premium certified polyurethane and Climalight fillings which are synonymous with respect for the environment, well-being and health for consumers and quality standards that will stand the test of time.

Coverings

Coverings available in a wide range of fabrics and leather.

Feet height

18 cm | 7.1"

Matte-black finish for foot and tubular-metal element.



available versions

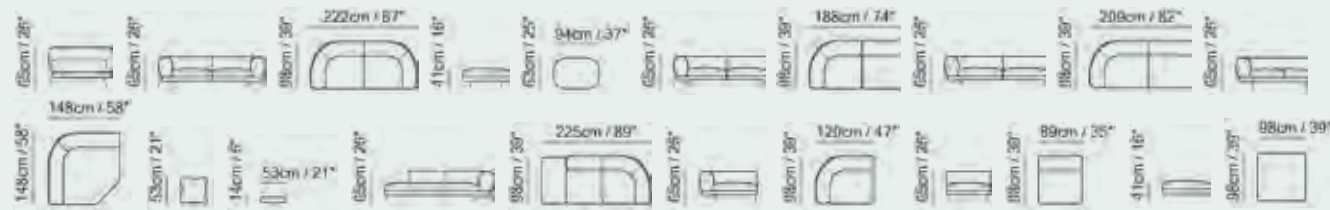

composition examples

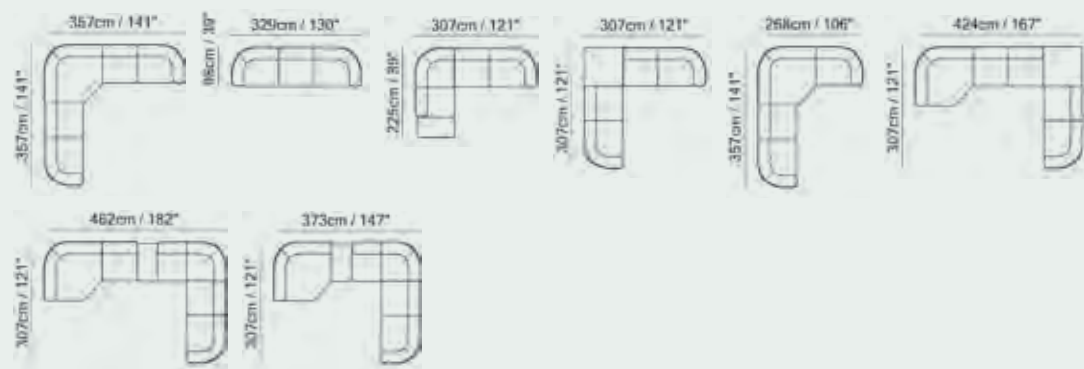

by Manzoni&Tapinassi

Opus is available in in-line and corner versions. Its extreme modularity allows it to be positioned in spaces of any size. The removable lumbar cushions support the body's position, ensuring maximum relaxation. The support surface on the side offers an integrated space to hold objects and magazines.

Padding

The mixture of padding in polyurethane, Memory Foam and 100% goose down provides support and a look that remains unchanged over time.

Coverings

The Opus sofa is available in a wide range of coverings in fabric and in fine Natuzzi leather in over 200 colours.

Feet height

12.0 cm | 4.7"

Feet available in metal finishes

- glazed nickel
- glossy chromed



available versions

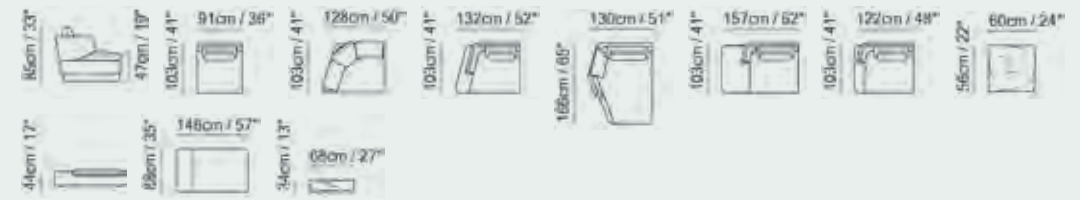

composition examples





by Claudio Bellini
Pablo allows you to adjust the backrests to varying heights, guaranteeing the utmost in comfort without compromising its modern style. The slender elegant armrests have been elevated with pewter satin-finish metal rings on both ends, matching the feet which have the same finish. Delivering a warranty of the utmost flexibility, it boasts various possible layouts and there is also the option of adding a grey-lacquered wooden top, a coffee table with a top in extra-white tempered glass and a pewter metal shaft, thus offering extraordinary levels of functionality.

Padding
Premium certified polyurethane fillings which are synonymous with respect for the environment, well-being and health for end consumers and quality standards that will stand the test of time.

Coverings
Coverings available in a wide range of fabrics and leather.

Feet height
17.0 cm | 6.7"

Feet available in
pewter



available versions

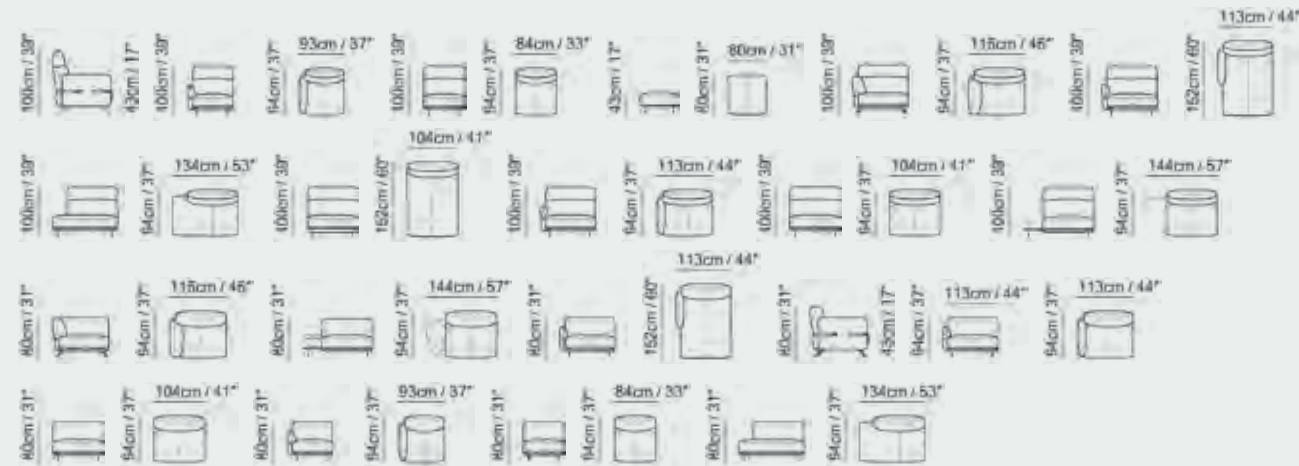

composition examples

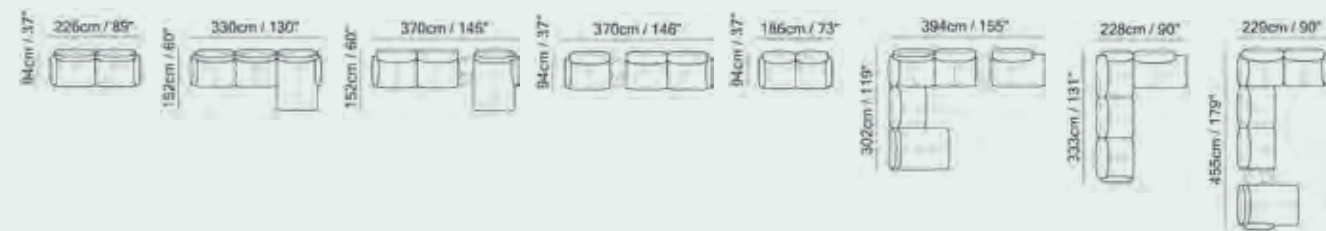

by Natuzzi Design Center
A whole array of linear and corner solutions, making it easy to adapt it to any space or usage. Hand-stitched and quilted details exalt the beauty of the design. relax functions
Each seat has been fitted with a soft-touch mechanism. A mere press of the recliner button causes the seat and backrest to open simultaneously. The Zero Wall space-saver system which activates the recliner function without having to detach the sofa from the wall behind it.

Padding
Eco-friendly non-toxic polyurethane padding, providing lasting comfort, and ensuring well-being and respect for the environment.

Feet height
13.0 cm | 5.1"

Feet available in metal finishes
- glossy chromed
- black chrome



Coverings
A wide gamut of upholstery in leather and fabric, so that the right one can be chosen for your home décor and lifestyle.

available versions

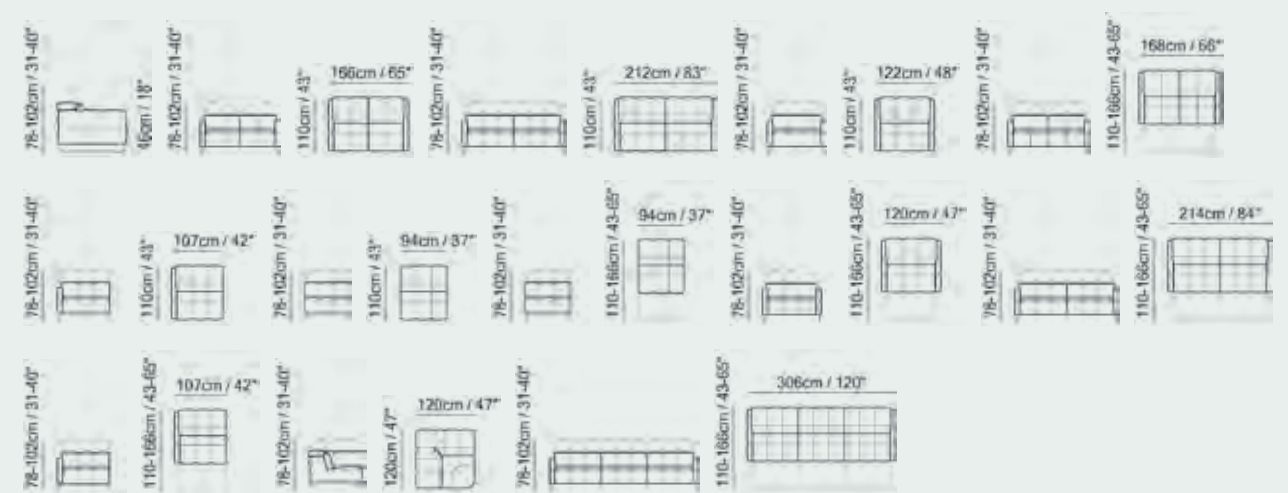

composition examples





by Natuzzi Design Center

Plaza is available in in-line and corner versions.

The original design of the armrest and the special angle of the seat lend the model energy and personality. The soft design makes it a symbol of the most enveloping comfort.

Additional options

The optional headrest is manually adjustable, allowing you to obtain your preferred position.

Coverings

The Plaza sofa is available in a wide range of coverings in fabric and in fine Natuzzi leather in over 200 colours.

Feet height
6.5 cm | 2.4"

Feet available in wood finishes

- walnut
- wengé
- metal finish
- glazed nickel



available versions



composition examples

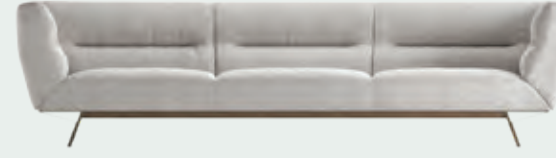

by Maurizio Manzoni

Available as a large 3-seater with 3 cushions, a 3-seater with two cushions and dormeuse.

The minimalist lines are embellished by the stitching on the backrest that emphasises the precision of the details.

The base in solid smoked oak reveals fine details in brushed brass.

Additional options

Optional cushions available in two sizes for improved comfort and looks.

Padding

The blend of exquisite polyurethane and Climalight padding, using special anti-allergy, breathable materials, ensures lasting good looks and support.

Coverings

Available in over 200 colours, the upholstery comes in fabric or exquisite Natuzzi leather.

Feet available in wooden finishes

- smoked oak



available versions



preludio pages 496



by Natuzzi Design Center
Sofa available in in-line and corner version with end unit and chaise longue. The open base and sled-type metal feet lighten the model's design.

Relax functions
The headrests and armrests can be adjusted to suit any comfort need.

Padding
The mixture of polyurethane and memory-foam padding guarantees remarkable comfort with a structure and look that remain unchanged over time.

Coverings
Upholstered in fabric or premium Natuzzi leather.

Feet height
12.0 cm | 4.7"

Feet available in metal finish
- glossy chromed



available versions

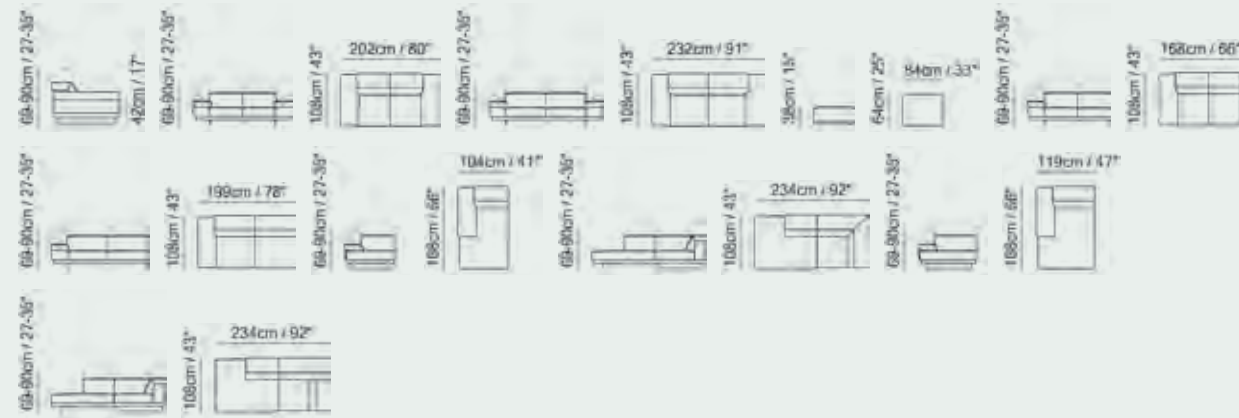

composition examples

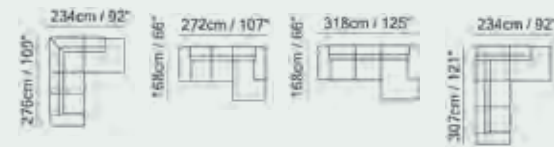

seagull 476, 479



by Claudio Bellini
A tribute to "visual comfort" which characterised Natuzzi's style in the 80s and 90s. Its characteristic slender armrests will not go unnoticed and appear to be delicately folded, conferring a fresh and original look.

Relax functions
With its soft and generous forms, it generates an immediate sensation of comfort, further enhanced by the electric relax mechanisms and adjustable headrest.

Coverings
Seagull is an open-based model available in leather or fabric.

Feet height
13.0 cm | 5.1"

Feet available in metal finish
- black chrome



available versions



composition examples

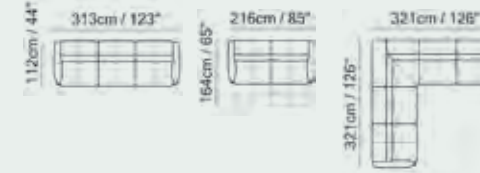



by Enrique Marti
Selva steals the limelight in all sorts of interiors with its modular elements which will help you create the right combination for your space and comfort requirements. Since seats are upholstered on all sides they can be placed separately throughout the house. The slip cover underneath the seat elements prevents them from slipping out of position.

Padding
A special microfibre and polyurethane are placed in a soft canvas zip-up inner liner in the seat cushions, preventing the padding from escaping when the covers are removed.

Coverings
Available in over 200 shades, the upholstery comes as fixed or removable fabric or in exquisite Natuzzi leather.

Feet height
20.0 cm | 7.9"

Feet and base in matte black metal with brushed brass

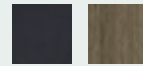

available versions



composition examples

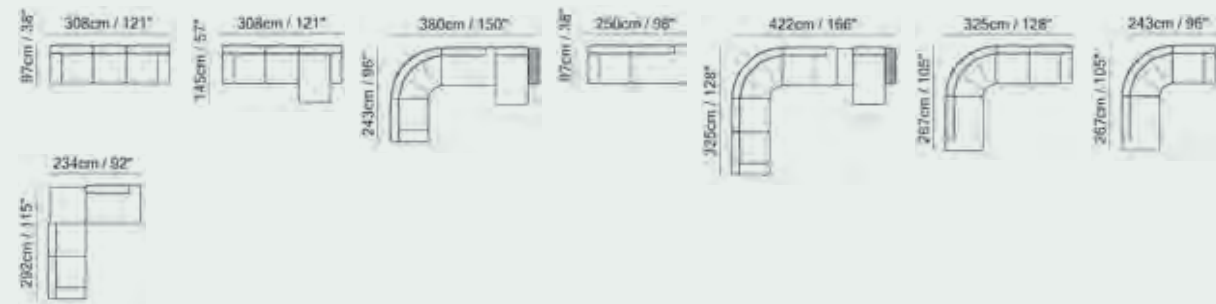

by Marcel Wanders studio
A modular system, making for a huge variety of different in-line and corner compositions, using open- and closed-base modules together. The modular seats feature intricate matelassé stitching on the backrest in a masterclass of elegant craftsmanship. Since seats are upholstered on all sides they can be placed separately throughout the house. Finally, Skyline also features tables, lamps, rugs, mirrors, bookcases and a bar area with a coordinated and distinctly contemporary look.

Relax functions
Each seat can be equipped with its own type of relax function. The manually adjustable backrest in its open-base modules offers a wide choice of seat depth. The closed-base modular seating elements can have either a manually adjustable headrest or a full-relax electric mechanism which moves the head-, back- and footrests.

The Zero Wall space-saving system activates the recliner function without having to move the sofa away from the wall.

Padding
The exquisite high-density polyurethane padding is anti-allergenic, breathable and elasticated, ensuring maximum comfort and lasting support.

Coverings
Available in over 200 colours, the upholstery comes in fabric or exquisite Natuzzi leather.

Feet height
20.0 cm | 7.9"

Open base modules with feet in die-cast metal available in two finishes:
- glossy chrome
- glossy black

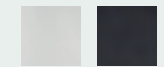

available versions

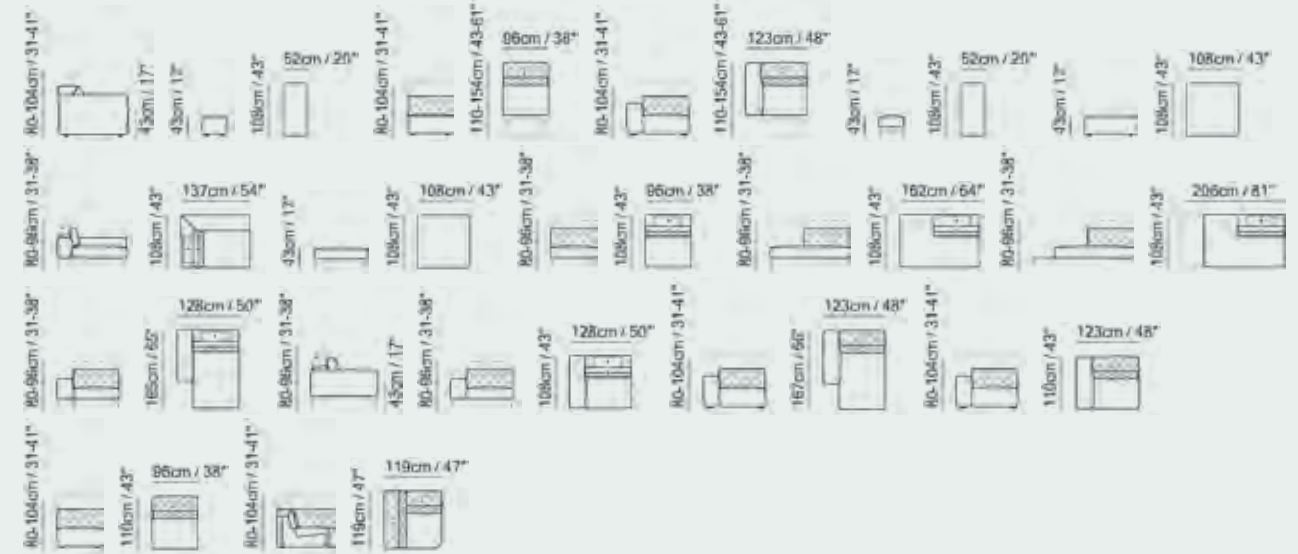

composition examples

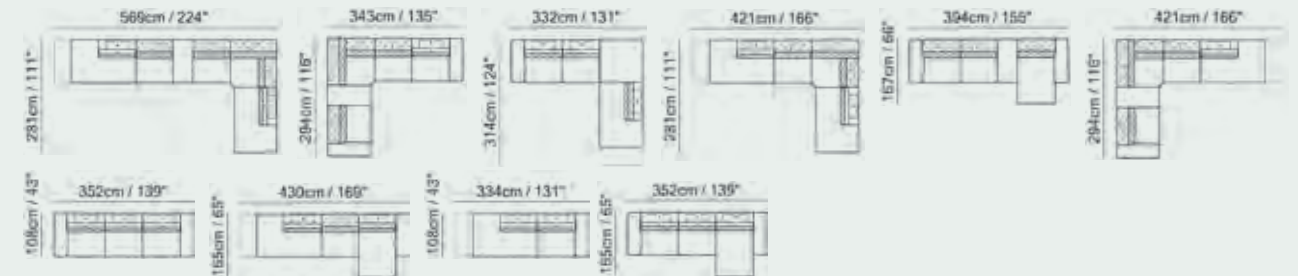



by Mauro Lipparini
Sohay combines minimal shapes with the typical comfort of Natuzzi Italia's padded furniture. Born from the need to mix form and function, it hides a practical and cutting-edge mechanism that allows you to transform it into a bed (with its armrest as a cushion).

Coverings
Upholstered in fabric or leather starting from cat. 25 Le Mans.

Pulling the handle between the seat cushions activates the hidden sliding mechanism that transforms the sofa into a bed. When the sofa is in leather, the handle is in the same leather covering of the sofa. When the sofa is in fabric, the handle can be in fabric (in the same covering) or in leather (picking from Le Mans or Status color palette).

Wooden base available in two finishes
- natural ash wood (54)
- black ash wood (51)

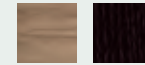

available versions



by Natuzzi Design Center
Modular sofa available in the linear and corner versions, with and without recliner function. The large abacus allows the creation of countless configurations suitable for all needs and spaces, thus adapting to the new demands of contemporary lifestyle.

Coverings
Upholstered in fabric or leather starting from category 10.

Padding
Seat and back cushions in high density polyurethane foam (density 35) that gives sustained comfort with an unchanged look over time.

Relax functions
Soft touch technology. By simply touching the buttons on the armrest you activate the relax Open/Close. Opening and closing movements are extremely fluid creating effortless reclining. Model has power combined headrest. The headrest opens first followed by the footrest; then the headrest has one final extra rotation for comfortable TV watching position

The relax system is also available with rechargeable battery pack (to avoid the unpleasant effect of the visible power cables when the couch is placed in the center of the room).

Zero Wall space-saver system which activates the recliner function without having to detach the couch from the wall behind it. Thanks to this mechanism, seat and back cushions can be reclined at a great length - the reclining seat becomes a proper chaise longue providing complete support to the legs.

Metal feet available in
- black chrome (FT78)
- glossy chrome (FT77)

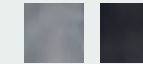

available versions



composition examples





by Enrique Marti

A pared-back design with generous seat cushions and tapered metal feet, giving this sofa a light airy feel. Available in both in-line and corner layouts but also as an armchair, it adapts easily to any living area. The 3-seater version measures just over 2 metres and you can choose larger or smaller seat sizes.

Relax functions

With Stan comes an incomparable experience of comfort: the Dual power mechanism features two different switches which activate the headrest and footrest separately. This enables you to adjust it until you find the position that suits you best. The Zero Wall space-saver system enables the recliner mechanism to be activated without having to pull the sofa away from the wall. The headrest has a dual function: it can be raised to provide enhanced comfort for taller people and reclined forwards manually to achieve the desired position while watching TV or reading a book.

Additional options

The fabric version of the sofa has been elevated with a leather detail that highlights its silhouette. You can choose the colour of the leather, which may contrast with or match the fabric.

Coverings

Upholstered in fabric or premium Natuzzi leather with exquisitely beautiful topstitching which brings out its sophisticated silhouette.

Feet height
11.0 cm | 4.3"

Feet available in metal finishes

- glossy chromed
- black chrome

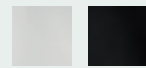

available versions



composition examples

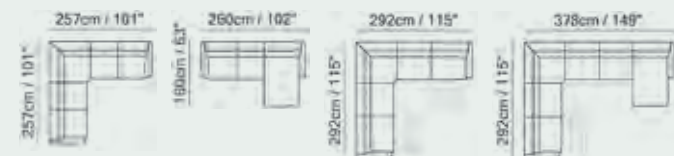

by Manzoni&Tapinassi

Sofa available in in-line, corner, and armchair versions.

Padding

The mixture of polyurethane, memory foam, and feather padding guarantees remarkable comfort, with a structure and look that remain unchanged over time.

Coverings

Upholstered in fabric or premium Natuzzi leather.

Feet height
14.0 cm | 5.9"

Feet available in
a unique powder-coated dark-grey metal finish



available versions

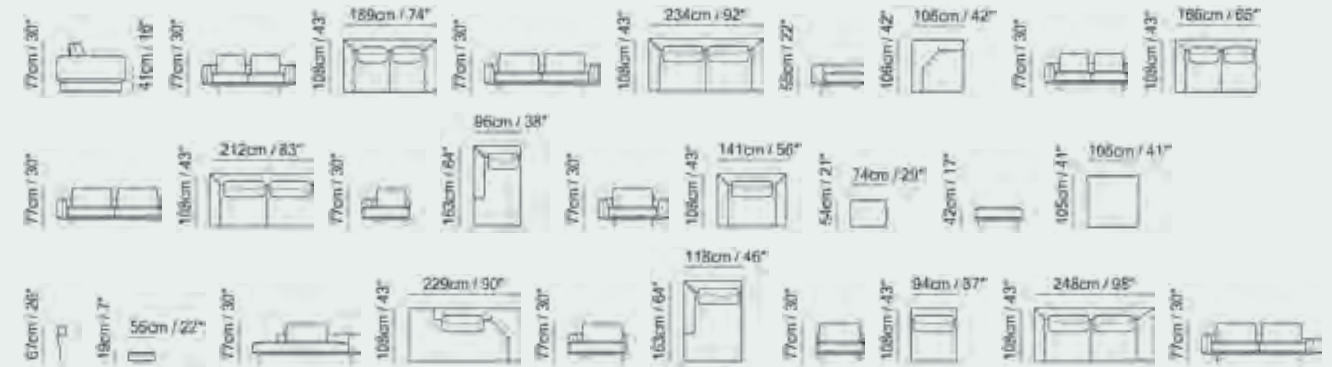

composition examples

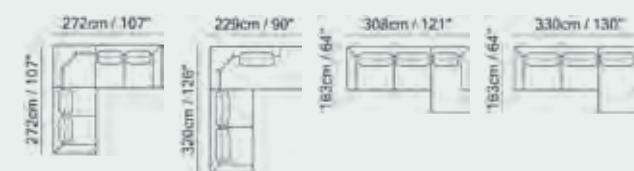

timeless

pages 88, 90, 95



by **Lorenza Bozzoli**

Modular sofa that unfolds with elegance and lightness. A large abacus of modules with organic shapes, lets you create countless configurations to meet different needs. All seats with hidden connectors and upholstered side panels.

Thanks to its timeless design, Timeless is suitable for both classic and contemporary environments.

Coverings

Upholstered in fabric or leather starting from cat. 25 Status.

Padding

Internal structure in molded polyurethane.

Production process:

1. Polyurethane resin shape.
2. Inside the mold there is a metal structure that acts as the backbone of the sofa.
3. Afterwards the high-density polyurethane (50) is injected into the mold.
4. After a specific period of time, this shape stiffens and becomes the body of the sofa.
5. This structure is bonded with a layer of transformed lower density polyurethane to give softness to the seat, to the back and armrests.
6. Everything is covered with dacron, leather or fabric.
7. The end result is a comfort, design and support unchanged over time

Hidden metal feet

available versions

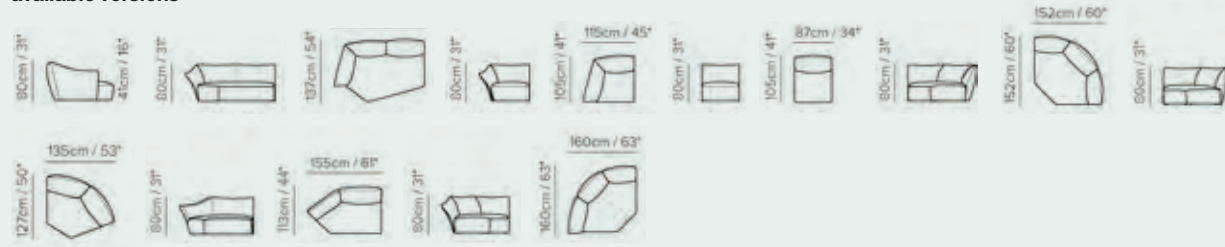

composition examples

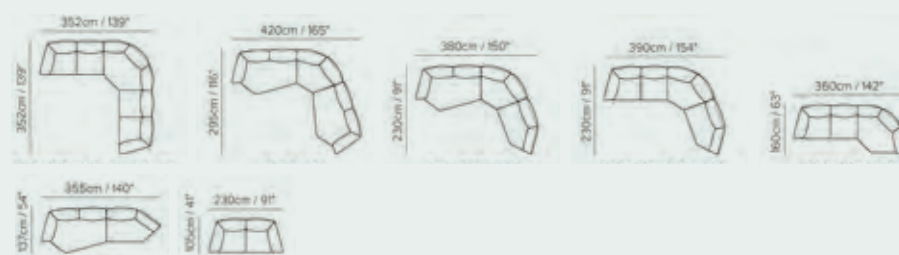

tratto

pages 400, 403



by **Maurizio Manzoni**

Sofa available in the 3-seater, 2-seater and armchair versions. Its contemporary design makes it the ideal choice for urban settings. It is perfect for small rooms too. The zigzag stitching details (also available in a contrasting shade) enhance its beautiful shape and linear design.

The open base and tall metal feet give this model an airy feel and allow for easy cleaning underneath

Coverings

Upholstered in fabric or premium Natuzzi leather.

Feet height
15.0 cm | 5.9"

Feet available in metal finishes
- glossy chromed
- black chrome



available versions



composition examples

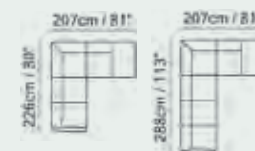



by Natuzzi Design Center

Metal feet and decorative edge on the entire profile of the sofa make this model very elegant keeping its simplicity. Available in linear and corner configurations, it's the perfect solution to furnish apartments in urban areas with limited space. The two-seater sofa is suitable for living and bedroom areas.

Coverings

Upholstered in fabric or leather starting from cat. 15 Le Mans.

Padding

Seat and back cushions in high density polyurethane foam (density 35) guarantee remarkable comfort, with a structure and look that remain intact over time.

Metal feet available in two finishes

- glazed nickel (FT75)
- glossy chrome (FT77)



available versions

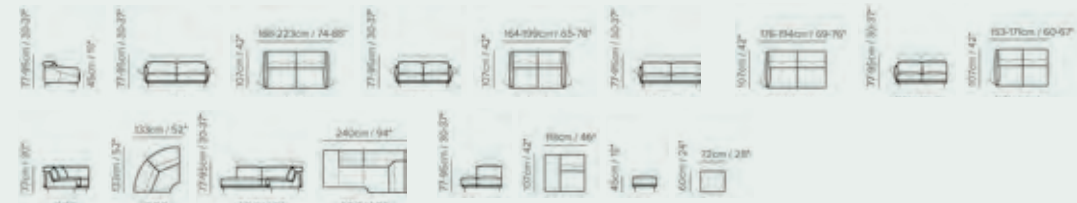

available versions

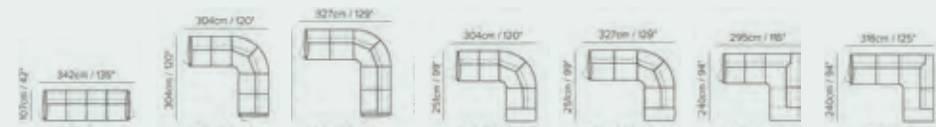

by Natuzzi Design Center

Sofa available in the in-line, corner and armchair versions, with and without recliner function.

Relax functions

Adjustable headrests on each seat. Soft-Touch mechanism available on each seat: a touch activates the recliner function by simultaneously opening the seat, backrest, and footrest. The model is also available with the Zero Wall space-saver system, which activates the recliner function without having to detach the sofa from the wall behind it.

Additional options

Artisanal stitching (also available in a contrasting version) reveals the extensive experience of Natuzzi in working leather.

Padding

The mixture of polyurethane and memory-foam padding guarantees comfort, support and look that remain unchanged over time.

Coverings

Upholstered in fabric or premium Natuzzi leather.

Feet height

11.0 cm | 4.3"

Feet available in metal finish

- glossy chromed



available versions

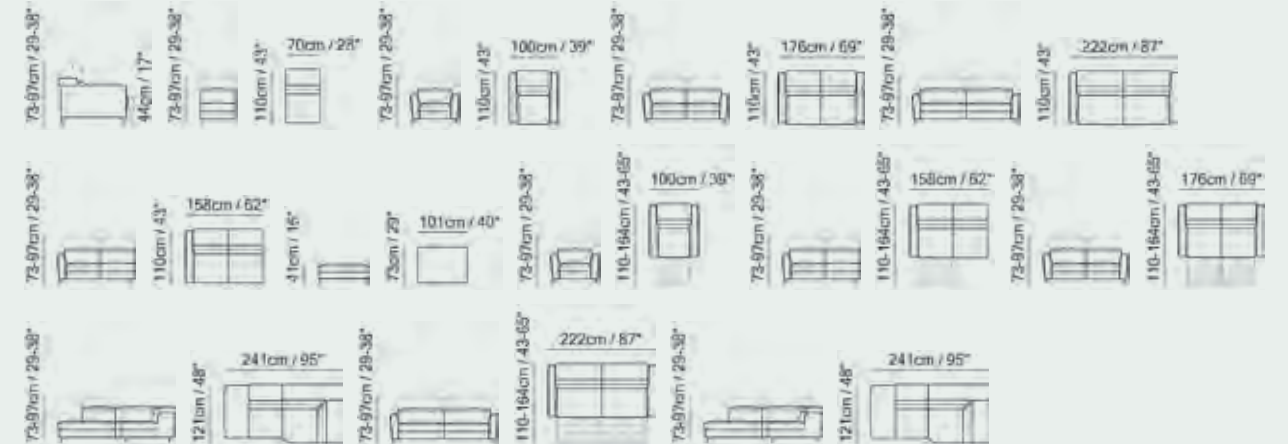

composition examples





by Nika Zupanc

Linear sofa available in 3-seater and 2-seater versions, together with an armchair and pouf. *Wave* boasts an elegant, sophisticated concept with a vintage charm which, in its enveloping shapes and sinuous lines, evokes the flow of sea waves. Curved to surround both the circular seat and the back cushions, the backrest creates a cosy and intimate space. The metal base has undergone a polishing and powder-coating process, a protective and decorative finish that guarantees superb scratch-resistance, exceptional durability and ease of cleaning.

Padding

The circular-shaped back is composed of a plywood frame upon which is placed an *undulating* cushion of high density polyurethane foam, ensuring maximum comfort. The padding of the seat and back cushions are composed of a quality-certified high-density polyurethane.

Coverings

Upholstery is available in a wide range of fabrics and leather.

Feet height
11 cm | 4.3"

Feet available in metal finish
- light gold



available versions

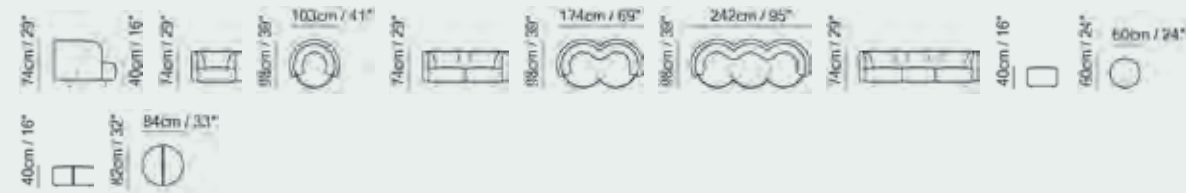

capriccio page 506



by Natuzzi Design Center
The Capriccio sofa bed combines simplicity and elegance for urban spaces. The "Ready bed" mechanism ensures ease of operation, going from sofa to bed and vice versa in one swift movement. The model is equipped with cushions stowed away in a space-saving hidden compartment and features include stylish metal feet. Model is available with contrast welt (or any another decorative detail such as a band under arm cushion).

Feet height
13.0 cm | 5.11"

Feet available in metal finishes
- glossy chromed
- black chrome



available versions



notturmo page 500, 503



by Natuzzi Design Center
Sofa available in the standard versions, with or without chaise longue, and in the 2-seater version with single beds. Sleeper function available in both the standard and corner versions. Spring mattress or Greenplus mattress with anti-bacterial and anti-allergy treatment. The rear part of the seat conceals a cushion storage compartment. The compact dimensions of the model make it an ideal solution for any space.

Coverings
Upholstered in fabric or premium Natuzzi leather.

Feet height
6.5 cm | 2.6"

Feet available in wood finishes
- walnut
- wengé



Relax functions
Adjustable headrests on each seat.
The Ready-Bed system allows the sleeper function to be activated with one easy gesture.

available versions



composition examples



re-vive casual page 518



by Natuzzi Design Center

Ergonomic shapes and cutting-edge technologies combine to offer an experience of absolute comfort.

It is the only armchair in the world that adapts to any seating position. Curled up, stretched out, in a log position, head down... finally, everyone can indulge in complete relaxation, exactly how they like it.

The personalisation process begins from the design, aiming to satisfy every stylistic taste: more welcoming, more contemporary, softer, more linear.

King or Queen? Choose your ideal seat size for maximum comfort.

The foot of each Re-vive armchair is supported by a base which mirrors its movements. The base is available in a variety of finishes.

Additional options

Optional coordinated footrest also available.

Coverings

Armchair upholstered in fabric or exquisite Natuzzi leather. The vast colour range available was created on the basis of a careful study of international colour trends.

Structure and base available in matte finishes

- nickel base/white spine
- nickel base/black spine
- nickel base/brown spine

Structure and base available in matte finishes

- black
- white
- brown



re-vive lounge page 519



by Natuzzi Design Center

The Natuzzi Re-vive chair Lounge is characterised by delicate quilting on the hand-made backrest and on the comfortable footrest. Available in thick leather too.

Additional options

Optional coordinated footrest also available.

Coverings

Armchair upholstered in fabric or exquisite Natuzzi leather. The vast colour range available was created on the basis of a careful study of international colour trends.

Structure and base available in matte finishes

- nickel base/white spine
- nickel base/black spine
- nickel base/brown spine

Structure and base available in matte finishes

- black
- white
- brown

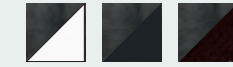

re-vive club page 519



by Natuzzi Design Center

Ergonomic shapes and cutting-edge technologies combine to offer an experience of absolute comfort.

It is the only armchair in the world that adapts to any seating position. Curled up, stretched out, in a log position, head down... finally, everyone can indulge in complete relaxation, exactly how they like it.

The personalisation process begins from the design, aiming to satisfy every stylistic taste: more welcoming, more contemporary, softer, more linear.

King or Queen? Choose your ideal seat size for maximum comfort.

The foot of each Re-vive armchair is supported by a base which mirrors its movements. The base is available in a variety of finishes.

Additional options

Optional coordinated footrest also available.

Coverings

Armchair upholstered in fabric or exquisite Natuzzi leather. The vast colour range available was created on the basis of a careful study of international colour trends.

Structure and base available in matte finishes

- nickel base/white spine
- nickel base/black spine
- nickel base/brown spine

Structure and base available in matte finishes

- black
- white
- brown

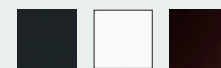

re-vive myway page 520



by Mauro Lipparini

The Natuzzi Italia icon takes on a new design featuring light geometric quilting: a style intended for rooms that express a strong personality.

Ergonomic shapes and leading-edge technology contribute to an experience of absolute comfort and a piece of furniture which adapts to every movement or position of the body.

It's the only armchair in the world that adapts to any seating position Curled up, stretched out, tucked in, upside down...finally everyone can relax completely, whichever way they desire.

Personalisation begins with the design itself to satisfy any taste: more accommodating, more contemporary, more yielding, more linear.

At the foot of a Re-vive is a base that supports it, following your every movement. The base is available in various finishes.

Additional options

Optional coordinated tilting ottoman.

Padding

Polyurethane and Climalight padding ensure lasting support and looks that endure over time.

Coverings

Upholstered in fabric or fine Natuzzi leather. Comfort comes in a broad range of shades selected on the basis of a careful analysis of international colour trends.

Metal Base and Plastic Cup under seat cushion available in standard finishes

- black
- white
- brown



re-vive quilted page 518



by Natuzzi Design Center

Ergonomic shapes and cutting-edge technologies combine to offer an experience of absolute comfort.

It is the only armchair in the world that adapts to any seating position. Curled up, stretched out, in a log position, head down... finally, everyone can indulge in complete relaxation, exactly how they like it.

The personalisation process begins from the design, aiming to satisfy every stylistic taste: more welcoming, more contemporary, softer, more linear.

King or Queen? Choose your ideal seat size for maximum comfort.

The foot of each Re-vive armchair is supported by a base which mirrors its movements. The base is available in a variety of finishes.

Additional options

Optional coordinated footrest also available.

Coverings

Armchair upholstered in fabric or exquisite Natuzzi leather.

The vast colour range available was created on the basis of a careful study of international colour trends.

Structure and base available in matte finishes

- nickel base/white spine
- nickel base/black spine
- nickel base/brown spine

Structure and base available in matte finishes

- black
- white
- brown

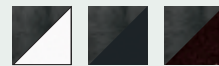

re-vive wing back page 520



by Natuzzi Design Center

Ergonomic shapes and cutting-edge technologies combine to offer an experience of absolute comfort.

It is the only armchair in the world that adapts to any seating position. Curled up, stretched out, in a log position, head down... finally, everyone can indulge in complete relaxation, exactly how they like it.

The personalisation process begins from the design, aiming to satisfy every stylistic taste: more welcoming, more contemporary, softer, more linear.

King or Queen? Choose your ideal seat size for maximum comfort.

The foot of each Re-vive armchair is supported by a base which mirrors its movements. The base is available in a variety of finishes.

Additional options

Optional coordinated footrest also available.

Coverings

Armchair upholstered in fabric or exquisite Natuzzi leather.

The vast colour range available was created on the basis of a careful study of international colour trends.

Structure and base available in matte finishes

- nickel base/white spine
- nickel base/black spine
- nickel base/brown spine

Structure and base available in matte finishes

- black
- white
- brown

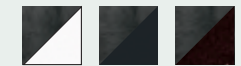

re-vive shuttle page 521



by Mauro Lipparini

Re-vive Shuttle encloses the supporting structure within the padding, highlighting its design and elevating its comfort to an even more extraordinary level.

The design features large side wings which convey a sense of welcoming warmth and protection. The highly ergonomic seat culminates in accommodating armrests.

Ergonomic shapes and leading-edge technology contribute to an experience of absolute comfort and a piece of furniture which adapts to every movement or position of the body.

It's the only armchair in the world that adapts to any seating position. Curled up, stretched out, tucked in, upside down... finally everyone can relax completely, whichever way they desire. Personalisation begins with the design itself to satisfy any taste: more accommodating, more contemporary, more yielding, more linear.

The grosgrain seams illustrate the craftsmanship required to produce this model.

At the foot of a Re-vive is a base that supports it, following your every movement. The base is available in various finishes.

Additional options

Optional coordinated tilting ottoman.

Coverings

Upholstered in fabric or fine Natuzzi leather. Comfort comes in a broad range of shades selected on the basis of a careful analysis of international colour trends.

Metal Base and Plastic Cup under seat cushion available in standard finishes

- black
- white
- brown

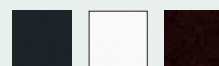

re-vive 610 page 521



by Natuzzi Design Center

Ergonomic shapes and cutting-edge technologies combine to offer an experience of absolute comfort.

It is the only armchair in the world that adapts to any seating position. Curled up, stretched out, in a log position, head down... finally, everyone can indulge in complete relaxation, exactly how they like it.

The personalisation process begins from the design, aiming to satisfy every stylistic taste: more welcoming, more contemporary, softer, more linear.

The foot of each Re-vive armchair is supported by a base which mirrors its movements. The base is available in a variety of finishes.

Additional options

Optional coordinated footrest also available.

Coverings

Armchair upholstered in fabric or exquisite Natuzzi leather. The vast colour range available was created on the basis of a careful study of international colour trends.

Metal Base and Plastic Cup under seat cushion available in standard finishes

- black
- white
- brown

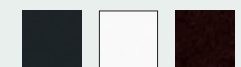



by Nika Zupanc

An iconic and sensual armchair composed of a single-piece frame and a high and voluptuous backrest: it spins around with a touch of *hi-tech glamour*. The cone-shaped base with *swivel* mechanism is composed of brushed metal with a *light-gold* finish. The metal has undergone a polishing and powder-coating process, yielding a protective and decorative surface that guarantees superior scratch-resistance, exceptional durability and ease of cleaning.

Padding

Moulded polyurethane-foam structure with wire mesh support to ensure its rounded form and superb strength. Seat cushion comes in processed polyurethane.

Coverings

Upholstery available in a wide range of fabrics and leather.

Base with *swivel* mechanism in brushed metal with a light-gold finish.



aftereight



by Natuzzi Design Center

Perfectly-proportioned armchair with a vintage design. The elegantly quilted high back provides excellent support and comfort. The elegant metal base, available in multiple finishes, elevates the model's sinuous lines.

Padding

The mixture of padding in polyurethane foam and ClimaLight guarantees unparalleled comfort with lasting support and a look that remains unchanged over time.

Coverings

Available in over 200 colours, the coverings come in fabric or fine Natuzzi leather.

The front feet are slightly higher than the back ones:

feet height

22.0/14.5 cm | 8.7/5.7"

Feet available in metal finishes

- glossy chromed
- black chrome



by Bernhardt&Vella

Amalia is an invitingly warm and welcoming nest, ideal for relaxation. A sofa with rounded lines, but also an armchair and an inviting dormeuse. Amalia is also available without armrests, a perfect solution both in a living room and in a sleeping area.

Padding

Its original rounded backrest embraces two large cushions filled with state-of-the-art polyurethane and Climalight padding which helps to improve comfort, while making it look invitingly soft and reassuring.

Available in over 200 colours, the upholstery comes in fabric or exquisite Natuzzi leather.

The front feet are slightly higher than the back ones:

feet height

11.0/26.0 cm | 4.3/10.2"

Feet available in wooden finishes

- smoked oak
- European walnut

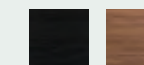

anteprima pages 85, 87, 496, 498



by Claudio Bellini

Compact size. Featuring a refined look, it is set on metal feet embedded in the frame and available in various finishes. The model adapts well to a variety of living spaces, such as the living area or bedroom.

Coverings

Armchair upholstered in fabric or exquisite Natuzzi leather.

Feet height

11.5 cm | 45.3"

Feet available in metal finishes

- glossy chromed
- black chrome

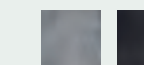

argo

pages 369, 370



by Paola Navone

Available as swivel-base armchair or 2- or 3-seater sofa.

The softness of its shape is accentuated by two gigantic clips sinking into and grasping the backrest – traversing it to shoulder height – and culminating in a bow detail at the back with a pop/glam vibe.

Padding

Mixture of premier-quality fillings: certified polyurethane, 4 cm of Memory Foam and Climalight - a special filling that reproduces all the fluffiness and supreme comfort of down.

Coverings

Available with a leather or fabric covering, or with the BYBORRE covering designed by the Dutch textile-innovation studio BYBORRE, using a yarn that combines premium-quality wool and PES.

Swivel base in metal matte black.



blossom

pages 128, 131, 303



by Claudio Bellini

The 50s make a stylish comeback in the Blossom armchair project. A highly inviting design alludes to the profile of a bud.

Generous shapes confer a distinct visual comfort which is confirmed by the quality of its upholstery. The bergère profile is framed by a wooden base for an eclectic and refined aesthetic result.

Coverings

Available in over 200 shades, the upholstery comes as fixed or removable fabric or in exquisite Natuzzi leather.

The front feet are slightly higher than the back ones:

feet height
20.0/15.0 cm | 7.87/5.91"

Feet available in wood finishes

- walnut
- wengé

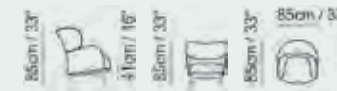
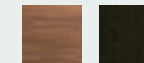

aura

pages 479, 483



by Claudio Bellini

Solid-wood structure available in a variety of finishes.

The model is available with a high or low backrest for optimum personal comfort.

Coverings

Armchair upholstered in fabric or exquisite Natuzzi leather.

Feet available in wooden finishes

- coffee-brown oak
- smoked oak
- olive walnut;

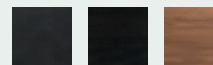

botanic pages 352, 354



by Claudio Bellini

A welcoming refuge which adds style and originality to your interiors.

Botanic reinterprets the style of the 50s, harmonising it in an open-based project with a metal base, clear features of later trends. Compact and elegant, it is ideal for home interiors or inviting public rooms.

Coverings

In fabric or leather, it generates an immediate sense of cosiness and hospitality, thanks to its soft and enveloping forms.

Feet available in metal finish
- matte black



butterfly pages 661, 663



by Natuzzi Design Center

The seat of the Butterfly armchair has perfect proportions with a soft, reassuring design.

Additional options

The armchair has a matching pouf to be used as a footrest.

Coverings

The Butterfly armchair is available also in a combination of leather and fabric.

The front feet are slightly higher than the back ones:

feet height
10.5/3.5 cm | 4.13/1.4"

Feet available in wood finishes
- walnut
- wengé

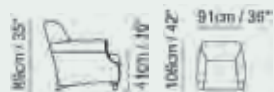
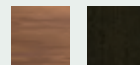

cammeo



by Maurizio Manzoni

The comfort of padding and the lightness of metal meet in an urban-looking design. The rear of the backrest and section below the seat are upholstered in leather.

Coverings

Armchair upholstered in fabric or exquisite Natuzzi leather.

Metal frame available in a metal finish
- glossy chromed



campus



by Mauro Lipparini

Campus is perfect for any living room space with its modular elements which will help you create the right combination for your space and furnishing requirements.

Since seats are upholstered on all sides they can be placed separately throughout the house. The slip cover underneath the seat elements prevents them from slipping out of position.

The Campus system also features tables, a sideboard, and a dining table and chairs.

Coverings

Available in leather or in removable fabric. Unusually, the inside of the arm- and backrest are in suede, while the main frame is upholstered with irregular weaves available in 7 colours.

Feet height
11.0 cm | 4.3"

Metal feet available in two finishes

- glossy champagne
- matte black with anti-scratch foot liners



Padding

The blend of exquisite polyurethane and Climalight padding, using special anti-allergy, breathable materials, ensures lasting good looks and support.



cassia page 399



by Mauro Lipparini

The deep seat and enveloping backrest provide an extremely pleasant lounging experience.

Coverings

Available in over 200 colours - in fabric, in fine Natuzzi leather or in a mixture of both.
In the version with two covers, the seat cushion is always upholstered in fabric and the internal and external body is upholstered in fabric.

Feet available in wooden finishes
- smoked oak
- European walnut

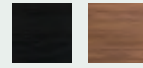

clemmie pages 271, 273



by Maurizio Manzoni

An angular take on the classic bergère with a British vibe. The tone-on-tone decorative hem that runs along the profile of the armchair highlights the design. The exclusive front bridge feet in metal are slightly higher than the rear ones in order to provide maximum comfort.

Padding

The seat cushion contains exquisite polyurethane and Climalight padding, special anti-allergenic, breathable materials that ensure lasting good looks and support.

Coverings

Available in over 200 shades, the upholstery comes in fabric or exquisite Natuzzi leather.

Feet height
23.0/15.0 cm | 9/6"

Feet available in metal finishes
- glazed nickel
- black chrome

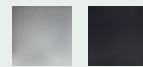

conca page 146, 221



by Claudio Bellini

This armchair's reassuring, rounded lines contrast with the rigidity of its Scandinavian-look feet.

Padding

Shell in top-quality polyurethane upholstered with exquisite Natuzzi leather.

Coverings

Seat and backrest in fabric. Available in a choice of over 200 colours, the upholstery comes in leather, fabric or a mixture of leather and fabric.

Feet height
35.0 cm | 13.8"

Metal-wood base available in metal with a
- coffee-brown finish and a wood insert in solid tobacco-brown ash.
- smoked oak

Feet available in metal finish
- black chrome



couture page 95, 144



by Manzoni&Tapinassi

The deep seat and enveloping backrest provide an extremely pleasant lounging experience. The Couture armchair is equipped with a large circular metal base which support the seat. The trim around the edges accentuates its distinctively rounded design.

Coverings

Available in over 200 shades, the wide range of coverings comes in fabric or fine Natuzzi leather.

Feet available in metal finish
- black chrome



deep

page 256



by Nika Zupanc

Low-slung base with hidden feet in black metal tipped with scratchproof rubber bumpers.

Padding

The fillings for the seat cushions and backrest come in high-density polyurethane and in Memory Foam.

Coverings

Coverings available in a wide range of fabrics and leather (which can also be combined).

Feet height

3.0 cm | 1.2"



dodi

pages 55, 385, 387



by Natuzzi Design Center

Thanks to its compact size and attractively elegant design, Dodi easily fits into any type of environment.

Coverings

The Dodi armchair comes in a wide range of leather or fabric (or mixture of both) coverings in over 200 colours.

Feet available in metal finishes

- glossy chromed
- black chrome

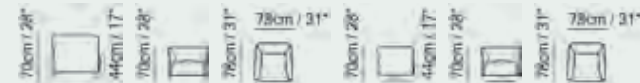

dolly

pages 379, 381



by Claudio Bellini

Armchairs available in leather and fabric.

Additional options

The trim (also available in contrasting colours) runs along the outer edge and emphasises the skilful craftsmanship.

Padding

The mixture of polyurethane and memory-foam padding guarantees extraordinary comfort, offering support and lasting good looks.

Feet height

13.0 cm | 5.1"

Feet available in metal finishes

- glossy chromed
- black chrome

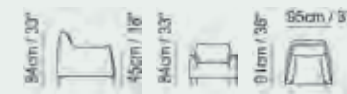

dove

pages 209, 214, 229



by Marcel Wanders studio

Dove comes in two versions – either as a chaise longue or an armchair.

The chaise-longue is light and dynamic, drawing inspiration from the silhouette of a dove, and its backrest adjusts to two sitting positions.

Its original asymmetrical shape stems from the fact that the horizontal lines come in a different length to the base.

The swivel base is in black chrome metal with a handy return function.

Additional options

One of the armrests is topped by a practical wooden tray, which gives a special touch to the design as a whole.

Padding

The structure is made up of moulded structural polyurethane together with polyurethane foam.

Coverings

Available in a choice of 200 different shades, the chaise longue and armchair come either in fabric or exquisite Natuzzi leather.

Feet height

32.0 cm | 12.6"

Metal base available in

- glossy black metal





by Elena Salmistraro

Ensis armchair is one of the symbols of the new Natuzzi Italia collection and of its attention to the new needs of contemporary living. In the shapes and coverings, it combines the Mediterranean lifestyle - which has always inspired Natuzzi - and the contemporary interpretation of a new, more demanding and more personal way of experiencing domestic spaces. The matching footrest allows you to amplify the relax position with style and elegance.

Coverings

Upholstered entirely in fabric or all in leather or in a mix of leather and fabric including Byborre.

Structure and padding

Internal metal tubular reinforcement drowned in the molded foam polyurethane that guarantees the round shapes, comfort and resistance over time. The part below the seat is in structural polyurethane, while the remaining parts are in molded foam.

Rocker and swivel function

Both the armchair and the footrest have the swivel base. The rocker function, instead, is guaranteed by a tilt mechanism that is activated by a lever placed under the seat. This mechanism allows to recline the backrest and the seat.



by Natuzzi Design Center

Fiorita is a power recliner chair, the Natuzzi's high-tech answer to the new demands of contemporary life. Thanks to invisible controls built into its structure, you can move its sophisticated Dual power mechanisms until you find the best position for your total comfort. An intimate and relaxed moment to take a break from everyday life. Fiorita embraces and supports you with a well-padded backrest. The solid steel swivel base allow Fiorita to rotate at your will.

Coverings

Available in fabric or leather from cat.15 Le Mans.

Product details

- Dual power motion recliner with soft touch buttons positioned between seat and armrest.
- Closing button equipped with the HOME function that closes all the mechanisms.

Metal base with 270° rotation available in

- matt black finish

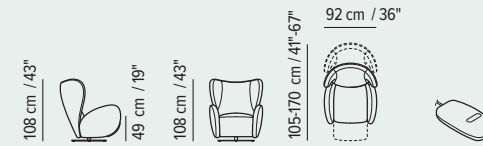

ilia



by **Mauro Lipparini**

Reclining armchair
Rechargeable battery pack available

Coverings
Upholstered entirely in fabric or all in leather.

Wood side panel available in
- Smoked Oak (32)
- Aged Walnut (34)
- Briar Frisé (35)

Metal base
Pewter finish (80)



itria

 pages 316, 319

by **Enrique Marti**

The open base gives a touch of modernity and makes this model look slimmer. This bold-looking armchair features clean yet sophisticated lines.

Coverings
Available in a choice of over 200 colours, it can be upholstered in leather, fabric or in a mixture of leather and fabric from Natuzzi's vast range. The external shell in leather contrasts with the fabric seat and backrest, creating an interesting mixture of shapes and materials.

Feet height
32.0 cm | 12.6"

Metal structure with finish in
- burnished black with rings and tips in brushed brass
- chocolate brown with rings and tips in rose gold

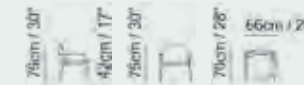
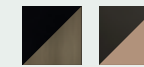

jeremy

 pages 404, 407

by **Manzoni&Tapinassi**

Armchair available in an in-line or corner sofa version. The premium materials reflect the quality associated with Natuzzi.

Padding
The mixture of polyurethane, memory foam and feather padding guarantees comfort, support and a look that remain unchanged over time.

Coverings
Upholstered in fabric or premium Natuzzi leather.

Feet height
17.0 cm | 6.7"

Feet available in metal finish
- pewter



lave

pages 203, 205, 677



by Marcel Wanders studio
A sculptural armchair with a metal mesh body inspired by fishing nets. Structure made from expertly worked metal tubes of different thickness with a polished chrome finish.

Padding
The seat cushions and backrest are padded with high-quality polyurethane.

Coverings
The cushion covers come in a wide range of options either in fabric or fine Natuzzi leather in over 200 colours.

Feet height
27.0 cm | 10.6"

Feet available in metal finish
- glossy chromed



logos

pages 359, 363, 457



by Manzoni&Tapinassi
Its versatile design makes this armchair ideal for the living area or bedroom.

Padding
The seat features a Memory-Foam insert for added comfort and to ensure lasting good looks.

Coverings
Armchair upholstered in fabric, exquisite Natuzzi leather or a fabric-leather mix.

Feet height
4.5 cm | 1.8"

Metal base available in metal finishes
- matte black



luna

pages 432, 435



by Claudio Bellini
Comfortably designed armchair featuring a generous headrest. The leather insert underlines the armchair's profile, accentuating its contours. Also available with a swivel base.

Coverings
Coverings in fabric, fine Natuzzi leather or a leather-fabric mix with a choice of over 200 colours.

Feet height
18.0 cm | 7.1"

Feet available in wooden finishes
- coffee-brown oak
- smoked oak

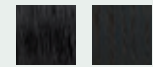

margaret

pages 149, 155



by Mauro Lipparini
The cosy design of the Margaret armchair makes it suitable for both the living area and sleeping area in a house. Also available in a rocking-chair version.

Padding
The backrest cushions and the seat are padded with high-quality polyurethane and 100% goose down for comfort that remains unchanged over time.

Coverings
The backrest cushions and the seat are available in a wide range of fabric coverings. The body of the armchair body is completely upholstered in leather.

Feet available in wooden finishes
- smoked oak
- European walnut

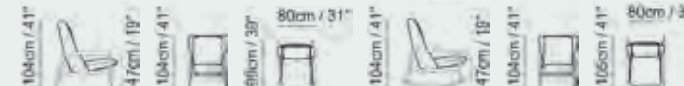
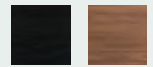

marlene pages 183, 339



by Paola Navone
A striking back panel which gives a sustained comfort.

Coverings
Armchair upholstered in removable fabric or fine Natuzzi leather.

Feet height
13.0/8.0 cm | 5.1/ 3.1"

Feet available in wood finishes
- walnut
- wengé

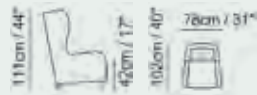
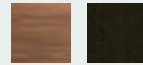

penelope page 104, 108, 109



by Mauro Lipparini
A universally suitable and highly versatile armchair suited to both residential and hotel settings.

Coverings
Available in fabric, fine Natuzzi leather and a mixture of both in a choice of over 200 colours. In the leather and fabric combination, you can choose between contrasting or tone-on-tone colours. In the leather and fabric combination, the whole armchair is upholstered in leather and the inner in fabric.

The front feet are in solid wood, while the rear ones are in metal.

Feet available in wooden finishes
- smoked oak
- European walnut

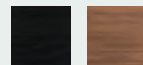

platea page 393, 466



by Natuzzi Design Center
With its rounded silhouette, the outer frame envelops the soft backrest and seat cushion of the Platea armchair.

Coverings
Armchair upholstered in fabric or exquisite Natuzzi leather.

Feet height
18 cm | 7.1"

Feet available in metal finish
- glazed nickel

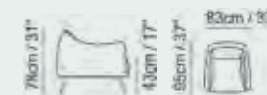

sleeping argo page 369, 370



by Paola Navone
The soft look is magnified by a bracket that sinks into the backrest – passing through it to reach the back, ending in a pop/glam knot.

Relax functions
Cutting-edge electric mechanisms operated using touch buttons.

Coverings
Available with a leather or fabric covering, or with the BYBORRE covering designed by the Dutch textile-innovation studio BYBORRE, using a yarn that combines premium-quality wool and PES.

Concealed feet in scratchproof metal.



talia

pages 446, 448



by Natuzzi Design Center

Great comfort is guaranteed by the lumbar support and the backrest, which is enveloping yet features a visually light design.

Additional options

In the fabric version, the trim around the edge of the armchair is in leather and is available in the same colour as the armchair; alternatively, it can be ordered in a contrasting shade.

Coverings

Talia is available in a wide range of coverings in leather, in fabric or in a mixture of both with a choice of over 200 colours.

The front feet are slightly higher than the back ones.

Feet height

33.0/26.5 cm | 13"/ 10.4"

Feet available in metal finish achieved by means of a galvanising process

- black chrome



tratto

page 400, 403



by Maurizio Manzoni

Armchair also available in a 3-seater and 2-seater sofa version.

Its contemporary design makes it the ideal choice for urban settings. It is perfect for small rooms too.

The zigzag stitching details (also available in a contrasting shade) enhance its beautiful shape and linear design.

The open base and tall metal feet give this model an airy feel and allow for easy cleaning underneath.

Coverings

Upholstered in fabric or premium Natuzzi leather.

Feet height

15.0 cm | 5.9"

Feet available in metal finishes

- glossy chromed
- black chrome

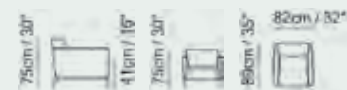

viaggio

pages 119, 125, 135, 176



by Manzoni&Tapinassi

Wooden structure.

Coverings

Armchair upholstered in fabric or exquisite Natuzzi leather.

Arms are available in metal with a lacquered coffee-brown finish

The front feet are slightly higher than the back ones:
feet height
26/19 cm | 10.2/7.5"

Feet available in wood finish - wengé

arms are available in metal with a lacquered coffee-brown finish

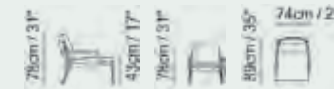

wave

pages 252, 256



by Nika Zupanc

Linear sofa available in 3-seater and 2-seater versions, together with an armchair and pouf. Wave boasts an elegant, sophisticated concept with a vintage charm which, in its enveloping shapes and sinuous lines, evokes the flow of sea waves.

Curved to surround both the circular seat and the back cushions, the backrest creates a cosy and intimate space.

The metal base has undergone a polishing and powder-coating process, a protective and decorative finish that guarantees superb scratch-resistance, exceptional durability and ease of cleaning.

Padding

The circular-shaped back is composed of a plywood frame upon which is placed an undulating cushion of high density polyurethane foam, ensuring maximum comfort. The padding of the seat and back cushions are composed of a quality-certified high-density polyurethane.

Coverings

Upholstery is available in a wide range of fabrics and leather.

Feet available in metal finish

- light gold



bis pages 385, 503

by Natuzzi Design Center
The pouf performs the most disparate functions – from an occasional seat to a support surface.
The stitched detailing always comes in taupe.

Feet height
2.0 cm | 0.8"

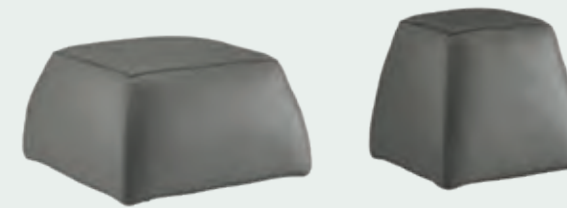

herman pages 176, 239, 240, 432



by Manzoni&Tapinassi
The Herman system includes in-line and corner sofas, with or without a chaise longue, as well as ottomans, benches and tables with a metal base. Each module is finished on all sides and can also be used as a standalone piece. Thanks to its extreme modularity, Herman allows for reusing the same elements over time by changing their position or using them on their own, adding a dynamic and original dimension.

Additional options
The matching or contrasting grosgrain insert further enhances the design and customises the pouf.

Feet height
4.5 cm | 1.8"

Metal spine available in metal finishes
- pewter
- glazed bronze

Coverings
Upholstered in fabric or premium Natuzzi leather.

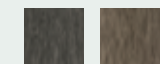

Padding
The mixture of expanded polyurethane, memory foam and Climalight padding guarantees remarkable comfort, with a structure and look that remain unchanged over time.

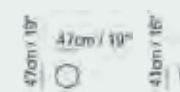

melpot pages 184, 187, 648



by Mauro Lipparini
Melpot is a symbol of modularity taken to its logical conclusion, making it the star of living spaces of any size. All the individual elements are interchangeable and can be repositioned as desired, or used singly. Ottomans, drawers, bookcase components and surfaces extend the versatility of the Melpot system, available in every linear and corner configuration, with or without chaise-longue. A mini collection of cushions in different colours, materials and sizes with different functions elevates the model's pared-back silhouette and enhances comfort levels.

Coverings
With over 200 colours to choose from, the range of fabrics or fine Natuzzi leather coverings allows for personalisation according to your tastes and requirements. Some items are available in quilted leather and fabric.

Feet height
6.0 cm | 2.4"

scacco pages 604, 607



by Natuzzi Design Center
Harmony has a round and cosy shape just like Scacco, designed for maximum comfort. Scacco creates your space and adds a touch of design to any room in the house.

Coverings
Available in fabric in all colours. Also available in our exclusive eco fibers Gaia and Byborre. Second cover (Natuzzi Italia logo bands) is always in leather from the color palette of the Le Mans article.

Padding
Scacco's polystyrene padding makes it light and easy to transport wherever you want. It easily adapts to your seat, giving you all the comfort you desire.



skyline pages 110, 203



by Marcel Wanders studio
The modular seats are a masterclass of elegant craftsmanship. Since seats are upholstered on all sides they can be placed separately throughout the house. Finally, Skyline also features sofas, tables, lamps, rugs, mirrors, bookcases and a bar area with a coordinated and distinctly contemporary look.

Coverings
Available in over 200 colours, the upholstery comes in fabric or exquisite Natuzzi leather.

Feet height
20.0 cm | 7.9"

Open-base modules with feet in die-cast metal available in two finishes achieved by means of a galvanising process
- glossy chrome
- glossy black

Padding
The exquisite high-density polyurethane padding is anti-allergenic, breathable and elasticated, ensuring maximum comfort and lasting support.

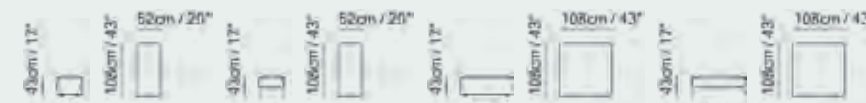

terra pages 28, 31



by Marcantonio

Terra is produced in Natuzzi Italia factories equipped with more than two thousand photovoltaic panels and a fluid-free heating system and is designed to be a totally eco-friendly product. It has an iconic design that can be used in different environments of the house.

Coverings

Available mainly in Eco-Fiber coverings like Byborre or Gaia, it is also naturally available in the vast leather and fabric Natuzzi collection.

Padding

Recycled polystyrene that make it light and adaptable in shape to achieve the desired comfort.



wave pages 254

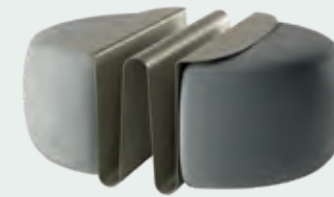

by Nika Zupanc

The pouf is composed of two half-moon shapes that can be joined in the middle by an elegant magazine rack made of curved, laser-cut steel sheeting with a polished and powder-coated light-gold finish and a smooth matte texture.

Coverings

Upholstery is available in a wide range of fabrics and leather.

Hidden feet

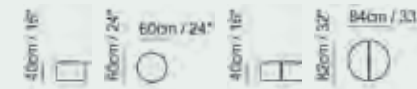

ambra

page 574, 580



by Natuzzi Design Center

Ambra chair is completely covered with fine Natuzzi coverings. The leather finish in particular emphasises Natuzzi's artisanal spirit and love of high-quality raw materials and processes. Ambra is available in two versions: with or without armrests.

With arms

- 67 cm x 63cm h 85 cm
- 26.38" x 24.8" h 33.46"

Without arms

- 55 cm x 63 cm h 85 cm
- 21.65" x 24.8" h 33.46"

frida

pages 187, 591, 593



by Mauro Lipparini

Frida is a lightweight dining chair with an angular accent backrest and edges outlined by a subtly contrasting trim. It has been fully upholstered in rawhide which brings to the fore its exuberant spirit and offers perfect seating comfort.

Without arms

- 53cm x 57cm h 88cm
- 20.87" x 22.44" h 34.65"

Finishes

- covering
burgundy, coffee brown,
dark brown, black, taupe, tan

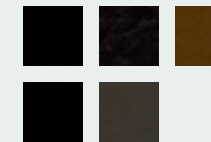

dove

page 209, 214, 229



by Marcel Wanders studio

Velvet and leather upholstery merge and are counterpointed by metal details. Dove has been curated down to the tiniest detail. With a structure in polished and painted black steel. It is equipped with a swivel and height mechanism to improve sitting comfort. Laser drawn steel base. Seat and backrest made of curved and painted sheet steel (tubular mesh) padded with high-density polyurethane and completely upholstered in a variety of colours.

Without arms

- 49 cm x 33 cm h 80 - 106 cm
- 19.29" x 12.99" h 31.5" - 41.73"

hedi

page 294



by Natuzzi Design Center

Hedi has a simple design, a comfortable high-quality polyurethane seat and an ergonomic flexible steel structure. The chair is entirely covered in leather (available in a variety of shades) and features an unusual trim around the edges which defines its silhouette.

Without arms

- 52 cm x 54 cm h 85 cm
- 20.47" x 21.26" h 33.46"

edgar

pages 528, 542, 548



by Claudio Bellini

A padded dining chair that combines comfort and contemporary design. A slender project that meets the modern needs of versatility without sacrificing the indistinguishable quality and aesthetic refinement of Natuzzi Italia.

With arms

- 62cm x 59cm H 89cm
- H seat 48 cm

Without arms

- 50cm x 59cm H 89cm
- H seat 48 cm

Finishings

- Available in fabric (cat. 83 and cat 99 - special fabric category 9K Byborre) and leather (cat. 15 Le Mans and cat. 30 Stromboli), in all the colours of the Natuzzi leather and fabric sample.

mama



by Natuzzi Design Center

Chair completely upholstered in leather or fabric and set on swivelling wheels. Mama has an internal wood and steel structure filled out with polyurethane. The inside of the backrest has a series of flexible steel inserts to guarantee improved comfort levels.

With arms

- 71 cm x 64 cm h 93 cm
- 27.95" x 25.2" h 36.61"

nanà pages 532, 612



by Patrick Norguet

The essential charm of the Nanà chair arises from how the elegant seat - a single shell in rigid black or white Baydur® with upholstered seats which can be combined with three different bases - allows you to maintain aesthetic continuity in the spaces, responding to multiple uses.

Baydur® is a fire-retardant high-density structural technopolymer, finished with polyurethane paints with a soft touch effect.

Version

- **233**
(total upholstered)
- **012**
(shell in Baydur® with internal seat and back upholstered)
- **031** (shell in Baydur® with seat upholstered)
* shell in Baydur® available white or black

Padding

The seat cushion padding is in medium density polyurethane.

Covering available

- Leather cat. 15 Le Mans
- cat. 30 Stromboli

Dimension

- **Dining chair with metal base:**
L62xP55 H82 cm;
H armrest 64 cm,
H seat 45-47 cm
- **Dining chair with wooden base:**
L62 P53 H82;
H armrest 64 cm,
H seat 45-47 cm

- Office chair with wheels:

- Metal Base white or black**
L62 P55 H82;
H armrest 64 cm,
H seat 45-47 cm



rose page 452



by Natuzzi Design Center

Dining chair completely upholstered in leather and fabric with a slightly curved backrest. The internal structure made from metal tubing has been cold foamed with high-quality polyurethane (density 45) to make the chair more comfortable.

With arms

- 62 cm x 62 cm h 80 cm
- 24.41" x 24.41" h 31.5"

shield page 214



by Marcel Wanders studio

The design detailing on the armrest subtly accentuates its inviting soul and contrasts with the slender structure. Bar stool with structure in polished and painted black curved steel. Seat and backrest made of curved and painted sheet steel (tubular mesh) padded with high-density polyurethane and completely upholstered in a variety of colours.

With arms

- 60 cm x 51 cm h 103 cm
- 23.62" x 20.08" h 40.55"

Finishes

- **frame**
black gloss chrome



pi greco pages 419, 484



by Manzoni&Tapinassi

Fully upholstered in leather and raw leather (or saddle leather and fabric), the Pi Greco chair features a durable metal frame for the legs and backrest as well as unique padded seats. Pi Greco is also highly practical and features anti-scratch and non-slip rubber feet for the protection of floor surfaces.

In addition to great comfort, this chair is aesthetically exquisite with fine details, such as the tonal stitching around the edges.

Without arms

- 51 cm x 56 cm h 79 cm
- 20.08" x 22.05" h 31.1"

sigma



by Manzoni&Tapinassi

Sigma features a metal frame padded on the backrest and seat which offers superior levels of comfort. It can be upholstered in saddle leather, leather or fabric, and has distinctive stitching detailing along the tone-on-tone finished edges.

Without arms

- 48 cm x 57 cm h 82 cm
- 18.9" x 22.44" h 32.28"

sovrana pages 441, 584, 587



by Claudio Bellini

Sovrana is a very versatile chair with a walnut or solid oak base. The seat and back supported by the structure in metal tubing has been made from high-quality cold-foamed polyurethane to make the chair more comfortable. The upholstered seat and back are fitted with elasticated webbing for unrivalled comfort. The chair is available in two versions: with or without armrests.

With arms

- 62 cm x 60 cm h 94 cm
24.41" x 23.62" h 37.01"

Without arms

- 48 cm x 60 cm h 94 cm
18.9" x 23.62" h 37.01"

Finishes

- **frame**
walnut, smoked oak

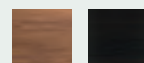

valle page 196, 568, 571



by Mauro Lipparini

Dining chair with solid ash foot brushed and dyed with a tobacco-brown finish. Stainless-steel champagne-hued-painted inserts. Chair with freely-rotating swivel mechanism. Back with details in curved plywood, padded with medium-density polyurethane and covered in leather or fabric. The back also has details in curved plywood. Seat completely padded with polyurethane and covered in leather and fabric.

With arms

- **High back**
61 cm x 61 cm h85 cm
24.01" x 24.01" h33.46"

- Low back

61 cm x 61 cm h79 cm
24.01" x 24.01" h31.10"

Finishes

- **frame**
tobacco-brown ash wood



tennis



by Chen Min

A dining chair designed to ensure maximum comfort thanks to the padded seat and the soft, welcoming backrest. The project is embellished by decorative side panels - under the armrests - that can be covered in leather or fabric. A touch of the indistinguishable quality and aesthetic refinement of Natuzzi Italia.

Dimensions

- Armrest Height 66 cm
- Seat Height 49 cm
- Backrest Height 88
- Depth 53,5 cm
- Width 59 cm

Finishings

- solid Ash wood structure,
10 gloss matt tobacco finish upholstered in fabric (cat. 83 and cat 99) and leather (cat. 15 Le Mans and cat. 30 Stromboli), in all the colours of the Natuzzi leather and fabric sample



vesta page 552



by Claudio Bellini

Featuring a wooden frame in solid ash, the Vesta chair combines simplicity and elegance and has been further elevated by the comfortable padding on the leather seat and backrest embellished with refined stitching. The sponging technique used for the finish gives the legs of the Vesta chair a distinctive aesthetic.

Without arms

- 48 cm x 60 cm h 89 cm
18.9" x 23.62" h 35.04"

Finishes

smoked ash, grey ash,
tobacco-brown ash



voyage

pages 243, 252, 558, 561



by Nika Zupanc

Chair base made from steel polished with interpon powder and coated with a matte gold-tone satin finish. Base equipped with a swivel mechanism. With a comfortable rigid design, the backrest has been made from cold-foamed polyurethane steel, fully padded and covered in leather or fabric. The seat features a padded cushion in medium-density polyurethane and has been completely covered in leather or fabric for a extraordinary levels of comfort.

With arms

- 64 cm x 53 cm h 71 cm
25.2" x 20.87" h 27.95"

Finishes

- **frame**
light gold



beat

pages 539, 541



by Massimo Iosa Ghini

With its enveloping lines and comfortable look, it matches the design of the sofa (Juno) created by the designer for the new Natuzzi Italia collection. Fully padded - seat and back - it has an internal metal structure worked with high-density molded polyurethane foam, available with leather or fabric covering. A project designed to offer continuity between the living and dining areas in both large and small environments.

Dimensions

70cm x 70cm H 90cm

Finishes

Upholstered in fabric (cat. 83 and cat 99) and leather (cat. 25 Status and cat. 30 Stromboli), in all the colours of the Natuzzi leather and fabric sample. Available also in new special leather cat. 60 Sahara.

briq

pages 618, 620



by Claudio Bellini

Available in different sizes to meet all space requirements. Also equipped with bedspring. Its pared-back aesthetic is a perfect counterpoint to the sumptuously padded and generous headboard. Slats in solid beechwood - a hardwearing and extremely outperforming type of wood. Frame in epoxy-powder-coated steel which is hugely resistant to chemical impact. Withstands corrosion, knocks and bumps. The two-opening positions mean that the bed is easily accessible from all sides. The first 45° position allows you to gain access to the storage unit while the second position is horizontal and lifts the base about 70 cm from the ground, enabling you to make the bed up easily.

Coverings

Covering available in fabric or leather. The headboard is covered at the back as well so that this piece can take centrestage in a setting.

cala

pages 624, 627



by Claudio Bellini

Cala is available in various sizes with a dual slatted base. The most elegant, refined part of the design of this bed is its softly upholstered headboard which boasts vertical stitched details for a touch of dynamism. The different positions of the front and back feet make the bed extremely elegant. The optional secret box with its sliding drawer below the slatted base makes it easy to store away bed linen and other objects. The Cala bed also features a bench with wood drawers available in the same coverings.

Coverings

The back also has removable covers in fabric or leather so the bed can even be placed in the middle of the bedroom.

campus

pages 596



by Mauro Lipparini

The elegant design of Campus bed finds its maximum expression in the headboard, softly padded and embellished by the interwoven Gargano split leather. The headboard is also covered in the back, so that it can be placed in the middle of the room.

Coverings

Upholstered in fabric or leather from 15 Le Mans. L025 available with Gargano woven leather to order as second cover. The first cover is associated with cushions that can be upholstered in leather or fabric. These cushions are removable. LR25 without weave and available in leather or fabric (single cover).

Sizes

Campus is available in 4 sizes: 160×200-180×200-153×200-193×200 cm. More sizes to meet every need of space and possibility to cover the bed with the wide range of leather and fabrics Natuzzi Italia.

Feet

Powder coated feet available in the same finishes of the sofa or ft 46 champagne or ft 79 matt black.

diamante

pages 632, 635



by Manzoni&Tapinassi

Padded bed available in various sizes. Also equipped with bedspring. Fully padded, upholstered headboards and side rails. The tall legs in lacquered metal infuse the design with an attractive airiness and make it easier to clean the floor. The back of the headboard comes in one single fully-padded piece. The curved headboard and hand-stitched detailing imbue this item with elegance and finesse.

Coverings

Upholstered in fabric or premium Natuzzi leather.

dolcevita

pages 643



by Manzoni&Tapinassi

Padded bed available in various sizes. Also equipped with bedspring. Headboard with lavish hand-quilting and button tufting, making for an extraordinarily plush aesthetic. Charcoal-grey metal feet thrust the bed up, giving it an airy elegance. The open base makes for easy cleaning under the bed.

Coverings

Upholstered in fabric or premium Natuzzi leather.

ema pages 608, 610



by Patrick Norguet

The majestic design of the Ema bed finds its maximum expression in the generous headboard that is softly padded and marked by simple and rigorous checkered stitching that give dynamism to the project. The headboard is also covered in the back to allow the positioning of the bed even in the middle of the room.

The size offer is wide to meet every space need. Versions L11-L12-L13-L14 with integrated slatted bed base.

Coverings

Upholstered in a wide range of high quality fabrics and leathers, starting from category 15 Le Mans.

Powder coated cocoa finish.

pincha pages 602, 604



by Natuzzi Design Center

Excellent design and comfort together with extreme functionality, thanks to its convenient storage function. Each side of Pincha is upholstered so the bed can also be placed also in the center of the room.

Coverings

Headboard also upholstered in the back. Upholstered in fabric or leather from category 15 Le Mans.

Sizes

Available in 4 sizes with split slatted base 160×200 - 180×200 - 153×200 - 193×200 cm.

Feet

Anti-scratch hidden feet.

fenice pages 646, 648



by Bernhardt&Vella

Padded bed available in various sizes. Also equipped with bedspring.

Metal corner feet that enhance the structure's solidity and aesthetic appeal.

The storage-space opening mechanism allows for two possible positions: in the first position, the bed can be made without having to bend down; the second position allows for arranging objects and bed linen in the storage compartment without any hassle.

Padding

Feather and polyurethane-padded headboard.

Coverings

Upholstered in removable fabric or premium Natuzzi leather.

piuma pages 654



by Claudio Bellini

Padded bed available in different sizes. Also equipped with bedspring. Fully padded headboard and base.

The open base makes for easy cleaning under the bed. The ruffle detail around the rim of the bed evokes the slightly puckered surface of a pillow edge.

Coverings

Upholstered in fabric or premium Natuzzi leather.

svevo pages 660



by Manzoni&Tapinassi

Padded bed available in various sizes. Also equipped with bedspring. The open base enhances the model's lightness and linear silhouette. Fully padded headboard offering maximum comfort. The solid-wood leg with a metal detail is visually striking and gives an impression of sturdiness.

Coverings

Upholstered in fabric or premium Natuzzi leather.

venere pages 632, 634



by Bernhardt&Vella

Padded bed available in different sizes to adapt to every space requirement. The ergonomic design of the headboard which is padded with high-quality polyurethane offers comfort and support. The headboard is also upholstered at the front to allow you to place the bed in the middle of a room. The tastefully upholstered conical feet taper downwards, visually lightening the design. The Venere bed elegantly furnishes the sleeping area and is completed by a bedroom system of the same name, consisting of bedside tables and drawers.

Coverings

Available in over 200 colours, the coverings come in fine Natuzzi leather or in a mixture of leather and fabric.

adam pages 21, 23



by Marcel Wanders studio

Adam collection also contains small accents tables available in different versions, central square and elliptical to meet different functions of living. Natural colors and elements such as wood and stone that are skillfully and elegantly mixed with the oldest craft history of Puglia. These elements fit perfectly well with each other thanks to the mix of different materials available.

Square central

L90 P90 H28 cm
L35 W35 H11"

Rectangular central

L120 P60 H37 cm
L47 W24 H15"

Round accent

D52 H55 cm
D20 H22"

Finishes

Lecce stone finish with innovative stone effect texture. This finish is composed with natural and recycled raw materials that allow to obtain natural surfaces, unique and valuable giving each element a changing and distinctive note. The spatulated Lecce stone finish has marble veins and shades that are the result of the artisanal application. The central crossbar matched for all versions is always in solid honey ash wood.



cabaret pages 390, 403, 407, 488, 491, 491, 496



by Natuzzi Design Center

The frame is in tubular metal painted with different finishes. The Cabaret line of coffee tables includes the following versions: square and round centre tables; round and square corner tables; a rectangular console table. Some versions of the Cabaret table are available with a white Carrara-marble or titanium-travertine top that has undergone a special sanding and brushing process and is protected by a special stain and scratch-resistant coating.

Square central

- L90 P90 H34 cm
L35.43" W35.43" H13.39"

Console

- L90 P27 H56 cm
L35.43" W10.63" H22.05"

Square corner

- L45 P45 H54 cm
L17.72" W17.72" H21.26"

Round corner

- D45 H54 cm
D17.72" H21.26"

Finishes

- frame

bronze, matte coffee brown, chrome glossy

- top

carrara white, anthracite, frosted, frosted white, frosted coffee brown, titanium travertine





by Mauro Lipparini
Campus collection, designed by Mauro Lipparini, evokes an evergreen but rigorous contemporary design. Collection of coffee tables, characterized by soft lines and harmonious silhouette. A succession of movements that outline a refined aesthetic value. The Best seller program of the Natuzzi Italia collection that expands its versatility and commercial proposal with new materials and dimensions. Campus confirms a strong identity of refined interior collection and modern decoration.

Square central
- L120 P120 H40 cm
L47.24" W47.24" H15.75"

Rectangular central
- L90 P140 H34 cm
L35.43" W55.12" H13.39"

Round central
- D100 H28 cm
D39.37" H11.02"
- D100 H 29 cm
D39.37" H11.42"

Round accent
- D47 H51 cm
D18.5" H20.08"
- D47 H52 cm
D18.5" H20.47"

Finishes
- frame
glossy champagne / tobacco-brown ash wood, glossy black chrome / eucalyptus wood
- top
glossy green glass, green calacatta marble, tobacco-brown ash wood, macchiavecchia ceramic

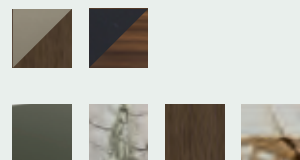

by Mauro Lipparini
Central tables available in two sizes and in various colour choices. Central tables made entirely from tempered extra-clear glass or with a transparent bronze and smoky effect with base and top in etched glass and/or back-lacquered in a set colour scheme. The accent version has a steel frame in painted matte coffee brown with an etched float-glass back-lacquered top, or also available in mirrored glass in various colours. All the glass parts are glued using a UV bonding technique that ensures maximum efficiency, strength and great transparency.

Rectangular central
- L100 P120 H28 cm
L39.37" W47.24" H11.02"

Round central
- L100 P100 H32 cm
L39.37" W39.37" H12.6"

Round accent
- L40 cm P40 H48 cm
L15.75" W15.75" H18.9"

Finishes
smoked glass with tonal base, bronze glass with tonal base, heavenly glass / extra clear matt coffee / smoked glass matt coffee / bronze glass



by Natuzzi Design Center
The frame of the Chocolat table comes in metal with a pewter finish protected by a scratch-resistant clear coating. The Chocolat coffee table is available in a centre or end version. Multiple tables can be placed next to each other to create larger composition. All the surfaces are waterproofed and stain resistant.

Multiform central
- L83 P101 H28 cm
L32.68" W39.76" H11.02"

Multiform accent
- L48 P57 H50 cm
L18.9" W22.44" H19.69"

Finishes
- frame
pewter
- top
smoked grey, imperial grey marble, athens silver cream stone



estro page 264, 382, 385



by Natuzzi Style Center
Set of coffee and accent tables available in various sizes and heights and useful for many purposes in the home. These tables can stand alone but create an exquisite aesthetic when used in combination with each other. Weight-bearing structure in sheet metal which is curved, polished and painted in burnished black. Tops available in various woods, in brushed marble or thick glass (19 mm) in different colours. The glass table tops have tempered glass lacquered on the underside and polished edges. Round Corner available with top in marble. Round Accent available with top in glass. Round Central available with top in wood.

Round corner
- D50 H55 cm
D19.69" H21.65"

Round central
- D90 H39 cm
D35.43" H15.35"

Round accent
- D40 H45 cm
D15.75" H17.72"

Finishes

- **frame**
burnished black

- **top**
walnut, smoked oak, green glass, invisible grey marble, sahara noir marble, lilac marble, brick-red glass

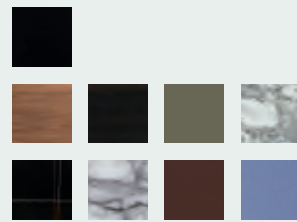

feudo pages 37, 81, 90, 93



by Mauro Lipparini
Generously sized round coffee table composed by two opposing cones in natural-stained solid Ash wood. In the upper cone there is a metal threaded bar that screws into the lower cone in order to raise the table by about 18cm.

Dimensions
D105 H40 up to 58 cm
D41.33" H15.74" up to 22.83"

Finishings

- **frame**
natural Ash wood

- **top**
open-pore Travertino stone
white glossy lacquer

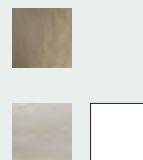

fil rouge pages 303, 413, 414

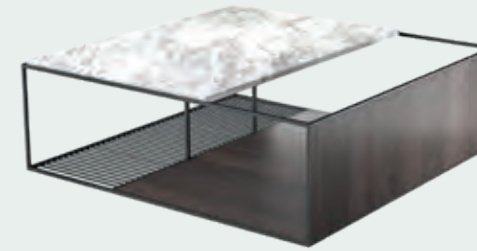

by Mauro Lipparini
The entire collection stands out for its mixture of coordinated elegant and sophisticated materials featuring marble, wood and metal. Fil Rouge has a metal tubular structure with a liquid varnish coat and a burnished finish. 6mm mesh of drawn metal rods with Tig welding. Surfaces, shelves and side panels in sliced oak combined with surfaces in smoothed, brushed Volakas marble.

Square central
- L100 P100 H34 cm
L39.37" W39.37" H13.39"

Rectangular multifunction
- L40 P120 H33 cm
L15.75" W47.24" H12.99"

Round accent
- D40 H48 cm
D15.75" H18.9"

Finishes

- **frame**
smoked oak, burnished black, black rose

- **top**
smoked oak, volakas





by Claudio Bellini

The glass seems to rest as if by magic on the stone bases. A skilful mixture of materials creates a sophisticated and elegant proposal for the living area. Frost collection introduces the Fossena Stone to the Natuzzi collection. It's a limestone of North-African origin and quarried in Tunisia. The stone has a compact and homogeneous background and is grey/brown in colour. Flitting rust-coloured shadows and subtle ivory veins enliven the surface of the Fossena stone.

The presence of some white salt or dark spots are another feature of this material. Available in both central and accent versions, this set of tables features two bases (cylindrical and rectangular) completely made of stone and attached by a pewter-painted steel tube.

Top in extra-clear tempered glass with a finished and polished edge (10mm thick). All the glass parts are secured to the stone bases with electro-welded steel elements and a UV gluing technique.

The glue used to weld the glass plates is cured with U.V. lamps; this creates a very strong bond. This gluing technique guarantees maximum effectiveness and resistance as well as great transparency.

Round central

- L100 P108 H30 cm
L39.37" W42.52" H11.81"

Round accent

- L50cm P55cm H50 cm
L19.69" W21.65" H19.69"

Finishes

- frame
grey fossena marble /
pewter metal,
Carrara marble /
pewter metal

- top
extra-clear glass

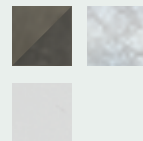

by Manzoni&Tapinassi

The Herman coffee tables are characterised by refined materials and a rigorous, precise style that makes them truly timeless. The frame of the Herman line is made of pewter-finished metal or bronze treated with a special scratch-resistant protective coating. Choice of mixed precious materials (top in wood or marble or glass) gives a very sophisticated and refined look. The various configurations can be combined to create unique arrangements that fit perfectly into their environment.

Square central

- L100 P100 H27 cm
L39.37" W39.37" H10.63"

Round corner

- D56 H50 cm
D22.05" H19.69"

Round accent

- D45 H34 cm
D17.72" H13.39"

Finishes

- frame
bronze, pewter
- top
coffee brown glass, smoked oak,
mirrored bronze, Orobico
marble, calacatta gold marble,
marble invisible grey, forest
brown marble

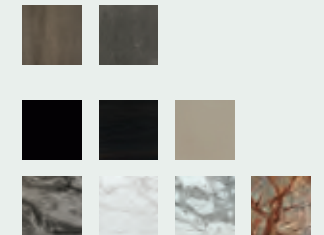



by Michele Menescardi
A collection of tables and accent side tables available with a 3/4 feet base in satiny sheet metal and varnished brass. The central leg in turned solid wood encapsulates the sophisticated soul of this model which combines high technology and haute design. The wooden side table, which accompanies the seat, has a top that rotates to 45° and features a steel-ball rotation system and blocking system with three positions (centre, right and left). Tray-top with milled solid wood edges, available various types of wood or coated with matte lacquer colours. Beautiful top in marble also available. Also available in the version with a top surface in smoothed, sanded marble.

Square central
- L100 P100 H32 cm
L39.37" W39.37" H12.6"

Square corner
- L55 P55 H56 cm
L21.65" W21.65" H22.05"

Rectangular central
- L80 cm P120 H39 cm
L31.5" W47.24" H15.35"

Rectangular accent
- L40 P55 H51 cm
L15.75" W21.65" H20.08"

Finishes
- frame
smoked oak/brass, walnut/brass
- top
walnut, smoked oak, matte beton, Orobico marble, matte chalk white, Volakas marble

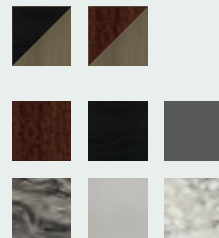

by Mauro Lipparini
The Ido coffee tables (to be positioned centrally and at the side) serve as tables, armrest-storage units and shelves and are set on slim, lightweight metal legs. The frame is made of pewter-coloured metal with a satin finish and anodised effect. The tops are made of thin stainless steel coated with a scratch-resistant protective finish, or in precious marble.

Round central
- D90 H39 cm
D35.43" H15.35"

Round accent
- D55 H56 cm
D21.65" H 22.05"

Square accent
- L40 P40 H47 cm
L15.75" W15.75" H18.5"

Finishes
- frame
pewter
- top
calacatta gold, black chrome, silver wave, invisible grey





by Mauro Lipparini

Ika is a complete set of coffee tables. The base of the coffee tables has been turned and polished comes in powder-coated tubular steel with a smooth bronze-coloured surface. The special painting based on polyester resins without pigments and additives has an excellent durability and guarantees excellent preservation of the brightness as well as colour stability. The base has a specially designed decorative foot in black ABS non-slip and non-marking plastic. The top has a bevelled rounded edge. The accent version with a lacquered top is equipped with a mechanism that allows you to adjust the height to different positions and adapt to the space available.

Central

- L64 P118 H35 cm
L25.2" W46.46" H13.78"

Accent

- L46 P55 H41-55 cm
L18.11" W21.65" H16.14"-21.65"

Corner

- L44 P94 cm H40 cm
L17.32" W37.01" H15.75"

Finishes

- **frame**
bronze
- **top**
natural oak, beige grey,
glossy sand

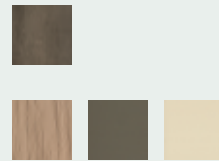

by Claudio Bellini

The Labirinto tables have castors making them easy to move around while the double-top coffee table can be used as a bookcase. Tempered glass available in various colours combined with mirrored glass partitions for a refined and contemporary look. All the glass parts are attached to electro-welded steel elements by means of a UV gluing technique. The glue used to weld the glass plates is cured with UV lamps; this creates a very strong bond. This gluing technique guarantees maximum effectiveness and resistance as well as great transparency.

Square central

- L100 P100 H34 cm
L39.37" W39.37" H13.39"

Square corner

- L60 P60 H70 cm
L23.62" W23.62" H27.56"

Rectangular central

- L85 P125 H34 cm
L33.46" W49.21" H13.39"

Finishes

- **frame**
bronze, smoke, transparent



by Manzoni&Tapinassi

The coffee and side tables have legs in solid oak or walnut and a top with a brushed open-pore surface featuring a pewter or brass metal insert that embellishes the design. The Kendo side table is a handy piece on which you can place a book or a glass and enjoy uninterrupted lounging.

Square central

- L100 P100 H26 cm
L39.37" W39.37" H10.24"

Rectangular central

- L90 P160 H26 cm
L35.43" W62.99" H10.24"

Rectangular accent

- L38 P53 H50 cm
L14.96" W20.87" H19.69"

Finishes

- **frame**
pewter / walnut,
smoked oak / brass
- **top**
walnut, smoked oak



by Natuzzi Design Center

Visual lightness combines with the practicality of hardened glass. Mercurio tables are made of curved float glass hot-forged with a smoked or clear finish. The Mercurio line of coffee tables includes a square corner version, a rectangular centre version and a console table.

Square corner

- L60 P60 H45 cm
L23.62" W23.62" H17.72"

Rectangular central

- L52 P111 H40 cm
L20.47" W43.7" H15.75"

Rectangular console

- L42 P140 H74 cm
L16.54" W55.12" H29.13"

Finishes

extra-clear glass,
smoky glass



orfeo pages 333, 335, 343



by Manzoni&Tapinassi
Combinations and mixtures of precious materials and attention for detail are the factors that run throughout the whole collection. Base and structure in lathed tubular metal (diameter 25 mm), polished and painted with end decorations. Structural intermediate elements in drawn, polished and painted metal. Top available in a mixture of 3 materials (marble, sliced wood and lacquer) supported by an under-surface in sheet metal (2mm thick). Side table with mirror top featuring an antiqued finish set on a support with rounded edges. The top is supported by an under-surface in metal.

Round central
- D100 H40 cm
D39.37" H15.75"

Round accent
- D60 H54 cm
D23.62" H21.26"

Finishes
- **frame**
burnished black / brass
- **top**
smoked oak / anthracite/
calacatta, bronze glass

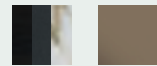

saturday pages 446, 451



by Natuzzi Design Center
Weight-bearing structure in shaped metal rods (12 cm thick), polished and painted in burnished black. Top (20 mm thick) veneered in various types of wood or with a gloss lacquer finish in various colours. The tables are fitted with feet in non-slip and non-scratch PVC.

Round corner
- D52 H45 cm
D20.47" H17.72"

Round central
- D70 H35 cm
D27.56" H13.78"

Round accent
- D38 H40 cm
D14.96" H15.75"

Finishes
- **frame**
burnished black
- **top**
smoked oak, glossy anthracite,
glossy chalk white, concrete
resin



patio pages 47, 49



by Sabine Marcelis
Thanks to the particular wheels that define the base, the Patio coffee table can be easily moved, thus becoming a functional support surface. The glass top is made of transparent Stopsol glass which contributes to its current and contemporary aesthetic. Functionality and design harmonize creating a versatile complement ideal for fluid and dynamic spaces that do not give up beauty and design as elements that improve life and help you feel good.

Dimensions
- L90 P90 H26 cm
L35.43" P35.43" H10.23"

Finishings
- Stopsol transparent glass



skyline pages 60, 61, 110, 203, 212



by Marcel Wanders studio
Set of coffee and accent tables available in various sizes and heights for different uses in the home. Feet in die-cast drawn and shaped aluminium, liquid-painted in various finishes. Top available in precious marble and/or granite with polished and brushed top with specific diamond brushes giving a matte effect. Visible edge polished and brushed to match the top. Marble top with water-repellent, stain and anti-scratch treatment. The Calacatta marble top is supported by a fibre-strengthening net which will ensure a better grip over time. These tables can stand alone but create an exquisite aesthetic when used in combination with each other.

Square central
- L85 P85 H22 cm
L33.46" W33.46" H8.66"

Rectangular central
- L40 P106 H40 cm
L15.75" W41.73" H15.75"

Finishes
- **frame**
glossy chrome,
glossy black chrome
- **top**
black granite, calacatta marble

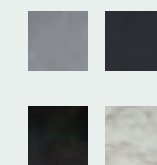

tempo

pages 164, 290, 297



by Manzoni&Tapinassi

The Tempo coffee tables feature an anthracite coated metal frame with a textured effect. Table top available in tempered satin glass in different finishes and colours, with a beautiful nickel silver metal effect, or in precious marble. The Tempo line comes in a central and side rectangular version as well as a square central one.

Square central

- L90 P90 H38 cm
L35.43" W35.43" H14.96"

Rectangular central

- L70 P148 H25 cm
L27.56" W58.27" H9.84"
- L73 P118 cm H39 cm
L28.74" W46.46" H15.35"

Rectangular accent

- L46 P56 H50 cm
L18.11" W22.05" H19.69"

Finishes

- frame

anthracite

- top

smoked oak, nickel silver,
glazed coffee brown, glossy
calacatta gold, lilac marble

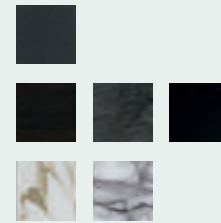

voyage

pages 243, 250

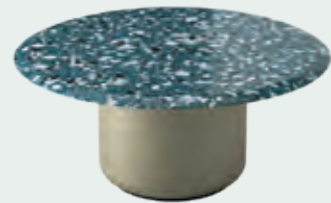

by Nika Zupanc

Voyage features a mixture of natural and industrial materials. The coffee-table central base is made of laser-cut curved steel. It has been polished with interpon powder coated with a matte, gold-tone satin finish. This special paint creates a protective and decorative surface that guarantees high scratch resistance, exceptional durability and easy cleaning.

Round central

- D100 H44 cm
D39.37" H17.32"

Finishes

- frame

gold

- top

stardust, gold glass

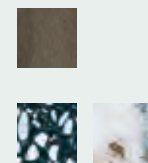

adam

pages 526, 528



by Marcel Wanders studio

A proposal that is the result of stylistic research involving new forms and materials. A timeless elegance and design distinguishes the Dining Adam, a great protagonist of the Natuzzi Italia Dining area.

Product details

- In the wooden version, the frame has legs made of honey-colored solid ash wood, with alternating running flame. Central crosspiece in honey-colored solid ash wood.
- In the all-wood version, the top is provided in honey ash essence height 5 cm with beveled edge and tone-on-tone undertop.

Dimensions

Elliptical-shaped dining table available in two sizes, suitable for 6 up to 10 people.

- L200 P100 H75 cm
L79 W39 H30"
- L280 P100 H75 cm
L110 W39 H30"

Finishes

Lecce stone finish with innovative stone effect texture. This finish is composed with natural and recycled raw materials that allow to obtain natural surfaces, unique and valuable giving each element a changing and distinctive note. The spatulated Lecce stone finish has marble veins and shades that are the result of the artisanal application.

The central crossbar matched for all versions is always in solid honey ash wood.

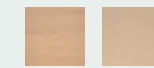

aliente pages 530, 532



by Marco Piva

Like a glider, which inspires even the name (aliente is the Italian for glider), the table combines technological research, sustainability, and design at the highest level. A project that highlights Natuzzi Italia's great attention to the needs of contemporary living - channelled into the concept of multifunctionality. A sculptural yet aerodynamic and light table, which combines form and function. The special steel mechanism that allows the extension of the top has indeed not only a functional value, but also an aesthetic one - and so the fact that the top, by extending, changes shape, giving life to an always-new architectural dialogue with the environment that hosts the table.

Dimensions

- L180 (ext. 270) P100 H75 cm
L70 (ext. 106) W39 H29"

Finishings

- black Ash wood frame
- dark grey back-lacquered glass top
- blonde Ash wood frame
- Calacatta Michelangelo top

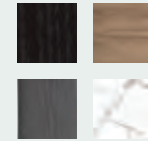

campus pages 196, 566, 568, 570, 571



by Mauro Lipparini

Campus features an ageless design with an acutely contemporary aesthetic. Exquisite materials and sleek lines unite to create sheer perfection. Its elliptical contoured top available in several shape and size finished with either marble or ceramic will take center stage in the living area, lending itself effortlessly to a whole array of different décor styles.

The round version is excellent to maximize any space and offer greater flexibility of seat and it's ideal for 6 - 8 seats. A large rectangular version is an ideal solution to accommodate more people and to be the undisputed protagonist of the room. It's ideal for 10 - 12 seats.

Rectangular dining table

- L210 P110 H75 cm
L82 W43 H29"
- L250 P110 H75 cm
L98 W43 H29"
- L300 P120 H75 cm
L118 W47 H29"

Round dining table

- D150 - H75cm
D59 - H29"

Finishes

- frame

glossy champagne /
tobacco-brown ash wood,
glossy black chrome /
eucalyptus wood

top

green calacatta marble,
macchiavecchia ceramic

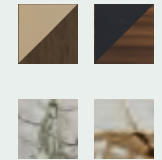

gutta pages 536, 539



by Massimo Iosa Ghini

A table inspired by nature, so strong and dominant in the Apulian landscapes - volumes and lines shaped by a vital impulse, a branch that bends in search of the sun, an irregular body of water that reflects its surroundings. Both versions, with round or elliptical top, have a light and refined solid American walnut structure that, in a continuous line, defines its outline starting from the foot and closing the profile of the top, emphasizing the organic and sinuous shapes of the project.

Dimensions

- L220 P117 H75 cm
L58 W53 H29"
- L149 P135 H75 cm
L86 W46 H29"

Finishings

- frame

American walnut

- top

Calacatta Gold Marble
American walnut

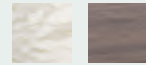

libra pages 542, 545



by Claudio Bellini

A table characterized by refined and thin lines. The sinuous legs, exceptionally made of Carrara marble, play on the contrast between the solidity of this material and the lightness of the design. The combination of marble and BETACRYL® (for the top) reveals an aesthetic research in which elements with opposite characteristics - naturalness and technology, glossiness and opacity - blend harmoniously. Available in elliptical version or circular version.

Dimensions

- L240 P110 H75 cm
L94 W43 H29"
- D140 H75 cm
D55 H29"
- D160 H75 cm
D63 H29"

Finishings

- frame

Carrara marble

- top

matt white BETACRYL® for the elliptical version
Carrara marble for the circular version

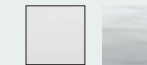

kendo pages 574



by Manzoni&Tapinassi

Its wooden structure is embellished with sophisticated metal inserts that create a vertical outline and intersect elegantly at the top, following along the outer side of the legs all the way down to the floor. The solid wood structure and the top are available in a choice of woods. The design and positioning of the legs gives all diners maximum leg room. Top in brushed open-pore oak or walnut featuring a pewter or brass metal insert, raising the design to new heights.

Rectangular fixed

- L100 P180 H74 cm
L39.37" W70.87" H29.13"
- L100 P260 cm H74 cm
L39.37" W102.36" H29.13"

Finishes

smoked oak/brass metal



new saturno pages 441, 582, 584



by Claudio Bellini

Fixed table, the ideal way to add a touch of elegance to the room. The practical and modern top is made from scratch-resistant tempered glass with an acid-etched effect and a screen-printed back. A table reveals deft detailing and refined workmanship typical of the finest woodworking traditions. The solid wood structure and the top are available in different finishes.

Rectangular fixed

- L100 P200 H74 cm
L39.37" W78.74" H 29.13"

Finishes

- frame

ash smoked, ash grey

- top

glazed white, glazed coffee brown, glazed rope, glossy sand glass



ombra pages 550, 552



by Claudio Bellini

Ombra has an asymmetrical supporting leg and metal base that simulates the reflection of its upper shadow. Table with thick pewter painted steel base (8mm) to guarantee greater stability. Leg painted and varnished curved wood with a decorative Bio-Mortar finish. It has a matte bio-compatible and eco-sustainable surface which is easy to maintain. The bio-mortar is an aqueous compound of single components with a mixture of natural materials and a thickness of about 2mm. The entirely manual technique means that there are distinctive on-of-a-kind marks which create a uniquely refined effect. An alternating running flame technique has been used to emphasise the grain of the top and characteristics of the wood. The wooden top is supported by a painted metal underlay that is attached to the leg via an internal metal core.

Elliptic fixed

- L95 P200 H75 cm
L37.4" W78.74" H29.53"
- L120 P240 H75 cm
L47" W94" x H29.53"

Finishes

- **frame**
pewter
- **top**
tobacco-brown ash wood



virgola pages 546, 548



by Claudio Bellini

"Virgola is an extendable table inspired by the culture of dining together", an expression of conviviality. The project is characterized by flexibility and functionality, without sacrificing the value of contemporary design. With a light and refined appearance, the table is available in two color versions and mixes with an elegant single-color and single-material FENIX top - expression of an innovative and performing material, extremely matt, anti-fingerprint, with low light reflectivity and high abrasion resistance.

Dimensions

- L140-180 P90 H74 cm
L55.12-70.91" W35.43" H29.13"
- L160-200 P90 H74 cm
L62.99-78.83" W35.43" H29.13"
- L180-230 P100 H74 cm
L70.87-90.55" W39.37" H29.13"
- L220-270 P100 H74 cm
L86.61-106.29" W39.37" H29.13"

Finishings

- FENIX orimoco cacao & Marquina Marmor extension
- coffee black metal legs
- FENIX efeso grey & Imperial Grey extension traffic grey metal legs



phantom pages 187, 588, 591



by Mauro Lipparini

The majesty of the wood and the lightness of the glass base make the design of this table highly distinctive. Two extra-clear glass plates support the table top, which seems to be suspended in the air. The base is completed by a solid wooden bar that runs parallel to the table top and connects the two plates. The top is veneered in open-pore brushed walnut with solid wood edges.

Rectangular fixed

- L95 P200 H74 cm
L37.4" W78.74" H29.13"
- L105 P260 H74 cm
L41.34" W102.36" H29.13"

Finishes

- **frame**
transparent
- **top**
walnut, smoked oak



voyage pages 243, 252, 556, 558, 564



by Nika Zupanc

Available in an oval or round shape, Voyage features a mixture of natural and industrial materials. Monolithic laser-cut curved base with a protective decorative coating in a new light gold tone that provides outstanding scratch resistance, exceptional durability and ease of cleaning; it can be combined with exquisite tops that have are extraordinarily abrasion resistant. Available in two different shapes and with two different top materials. STARDUST top - Terrazzo Stone: an agglomerate composed of an exquisite mixture of marble and resin selected and customised for Natuzzi. The material is then finished and smoothed. The edges of the top are finished with a curved bevel. Top in Gold & Glass: Top made of laminated glass (8 + 6mm thick) covered with digitally printed silver film.

The personalised image selected by the Natuzzi Style Center puts an elegant spin on the natural beauty of stones and marble. The round version of this table is only available with a Gold & Glass top.

Elliptic fixed

- L110 P 220 H75 cm
L43.31" W86.61" H29.53"

Round fixed

- D138 H75 cm
D54.33" H29.53"

Finishes

- **frame**
gold
- **top**
stardust, gold & glass



fil rouge pages 503, 505



by Mauro Lipparini

The entire collection stands out for its mixture of coordinated elegant and sophisticated materials featuring marble, wood and metal. The Fil Rouge desk has a metal tubular structure finished with a coat of varnish and a burnished surface. Surfaces, in sliced oak combined with smoothed, brushed Volakas marble. The desk has a drawer with a drop-down door and decorative metal handles.

Rectangular desk

- L43 cm P130 cm H73 cm
L16.93" W51.18" H28.74"

Finishes

- **frame**
smoked oak/burnished black, burnished black
- **top**
volakas



ika page 160



by Mauro Lipparini

The base of the desk is made of turned tubular steel with a polished powder-coated surface and a smooth bronze-coloured effect. The special painting based on polyester resins without pigments and additives has an excellent durability and guarantees excellent preservation of the brightness as well as colour stability. The base has a specially designed decorative foot in black ABS non-slip and non-marking plastic. Top with a bevelled edge in natural oak enhanced with a running-flame technique and featuring decorative bubbles in matte lacquer. The Ika desk can be completed with a fully lacquered chest of drawers (an optional item sold separately). Boasting a storage drawer with a curved plywood front and an open compartment. The drawer is fitted with a blumotion soft-closing system. Drawers are completely lacquered with a matte finish and equipped with swivel wheels for simple movements.

Rectangular console

it has an organic beauty
- L68 P130 H75 cm
L26.77" W51.18" H29.53"

Drawer

- L50 P37 H58 cm
L19.69" W14.57" H22.83"

Finishes

- **frame**
bronze
- **top**
natural with details in lacquered grey beige



inu pages 614



by Patrick Norguet

Protagonist of the home office area is the Inu table-desk: a large worktop - rectangular and extensible - with comfortable dimensions. Versatility is the word that best sums up this new project, a feature that gives INU the functional elements that facilitate work from home, and at the same time a generous dimension that also allows you to gather around him for convivial moments. For this reason, the table is made with a large worktop in FENIX - a very innovative material with high performance - with a base in natural ash wood, equipped with functional details such as the hidden channel designed specifically for the passage of electrical cables. Its elegance and simplicity of design make it easily integrated into the living room.

Dimensions

- L180 P90 (ex. 108) H 72 cm
L70.87" P38.58" (ex. 45.58") H 20.35"

Finishings

- FENIX white
- natural Ash wood
- white metal bar
- FENIX black
- black Ash wood
- black metal bar





by Manzoni&Tapinassi

The top of the Omega desk is elegantly set on a metal frame that gives it a contemporary look. The desk is available with a metal structure and a top in a variety of beautiful marbles. There is an option of the drawer in different lacquered shades.

Rectangular desk

- L52 P133 H76 cm
L20.47" W52.36" H29.92"

Rectangular desk drawer

- L34 P38 H8 cm
L13.39" W4.96" H3.15"

Finishes

- **frame**
matte anthracite
- **top**
waxed calacatta gold marble,
sahara noir marble



by Mauro Lipparini

The design of the desk centres on the use of different materials and finishes, such as the juxtaposition of wood and glass. The structural foot of the desk comes completely in full-thickness (19 mm) extra-light tempered glass. The drawers have a push-pull opening mechanism with an elegant front panel in curved wood.

Rectangular desk

- L60 P180 H73 cm
L23.62" W70.87" H28.74"

Finishes

- **frame**
extra-clear glass
- **top**
walnut, smoked oak





by Marcel Wanders studio
Exquisitely elegant details loaded with finesse make Arch the focus point of any living space. It features a combination of materials and finishes that give it striking visual appeal. A beautiful bookcase which encapsulates the essence of the architecture of Apulia. A series of arches creates a succession of mirror images which playful explore the idea of transparency. Free-standing bookcase with double-sided mirrored glass details. Shelves in black stained flamed ash wood. Decorative tempered transparent smoky glass at the front and sides of the bookcase. The back of the Arch bookcase is finished with a mirror in smoky tempered glass. Bookcase with adjustable feet. Available version with right and left arc.

Bookcase
- L83 P40 H210 cm
L32.68" W15.75" H82.68"

Finishes
black gloss chrome/mirrored
smoky glass/black ash wood shelf

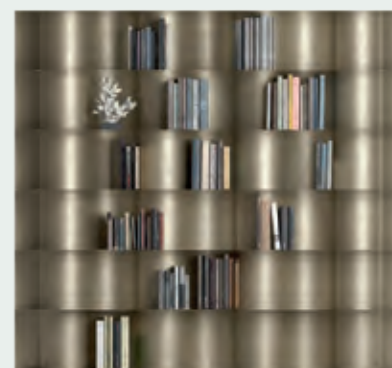

by Nika Zupanc
Modular bookcase with elements available in two sizes that can be superimposed and combined with each other to create different compositions. A laser-cut curved steel sheet that is polished with a smooth, matte gold-tone finish. The special painted finish creates a protective and decorative surface that guarantees high scratch resistance, exceptional durability and easy cleaning. Fully assembled structure with 3mm-thick painted steel shelves. The structure is equipped with a wall hooking system to ensure greater stability and anti-tipping safety. The small module can be hooked to the wall and placed alongside other elements of the same version to create suspended compositions.

Bookcase
- L46 P100 H61 cm
L18.11" W39.37" H24.02"
- L46 P100 H124 cm
L18.11" W39.37" H48.82"

Finishes
- **frame**
light-gold metal



by Mauro Lipparini
The vertical elegance of the bookcase will make a room seem more spacious with its neat surfaces, minimalist design and playfully overlapping planes. Its sharp geometrical stylishness is enhanced by the frame which is reminiscent of a graph, defining and reconfiguring space. The entire collection stands out for its mixture of coordinated elegant and sophisticated materials featuring marble, wood and metal. The Fil Rouge bookcase has a metal tubular structure with a liquid-varnish coat and a burnished finish. 6 mm mesh of drawn metal rods with Tig welding. Self-supporting bookcase with adjustable feet.

Product Details
Side panels and shelves in sliced oak or walnut combined with surfaces in smoothed, brushed Volakas marble. Free-standing piece of furniture with adjustable feet and internal elements that can be combined to create different looks.

Bookcase
- L40 P90 H142 cm
L15.75" W35.43" H55.91"

Finishes
smoked oak/burnished black with marble volakas shelves, burnished black with marble volakas shelf





by Marcel Wanders studio

The Skyline Bar Desk is a simple yet exquisite piece of furniture that has evolved from our Natuzzi lifestyle concept and our idea of home living. It abounds in shelves and storage compartments for every kind of cocktail and drink preparation. Useful drawers for tablecloths and napkins.

Bar Desk with storage structure and shelves in black ash wood with a matte finish. Exterior coated with tempered mirrored smoky glass. Details in polished tubular steel. Top in absolute black granite with a polished and brushed surface achieved with specific diamond brushes and featuring a matte effect. Granite top enhanced with a water-repellent, stain and anti-scratch treatment. Visible edge polished and brushed to match the top. The cabinet interior has been fitted with extra drawers that can be partially opened and features decorative metal-painted handles. Drawer fronts in black ash wood.

Dimensions
L75 P154 H108 cm
L27.95" W60.63" H42.52"

Finishes
- **frame**
black ash wood
- **top**
granite black



by Mauro Lipparini

Laser-cut, polished and nickel-plated galvanised steel base with a champagne-coloured liquid-painted surface. The metal base has been detailed with inserts in solid tobacco-brown finished ash wood. Frame tobacco-brown ash wood. Inside of the sideboard comes in the same wood. Hidden drawers in wood with metal handle detailing make this piece of furniture even more functional. Side doors with frame and detailing in tobacco-brown strips of solid ash wood embellished with transparent tempered bronze glass. Internal shelves come in tempered bronze glass.

Sideboard with doors
- L220 P54 H72 cm
L86.61" W21.26" H28.35"

Finishes
tobacco ashwood / champagne
black chrome / eucalyptus.

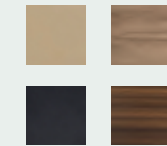

by Mauro Lipparini

The Campus wooden TV unit can bring a touch of elegance and functionality to any living room. The compartments and shelves allow you to insert technological devices and hide TV cables.

Dimensions
L200 P42 H50 cm
L79 P16,5 H20"

Finishes
Top and side parts completely made of Eucalyptus wood. Campus TV unit provides a base in laser-cut, polished and liquid-coated steel sheet in glossy black chrome. The metal base features details with eucalyptus wood inserts. The cabinet is equipped with a central compartment with a central shelf in transparent tempered glass, where you can insert technological appliances. Central transparent corrugated glass door with push to open opening mechanism. Side storage compartments completely made of eucalyptus essence internally and externally equipped with push to open doors and side cable passage. Back of the cabinet fully refined.



fil rouge pages 233



by Mauro Lipparini

Fil Rouge has a metal tubular structure with a liquid varnish coat and a burnished finish. 6mm mesh of drawn metal rods with Tig welding. Surfaces, shelves and side panels in sliced oak combined with surfaces in smoothed, brushed Volakas marble.

Sideboard

P50 L180 H61 cm
P19 L70 H24"

P50 L200 H75 cm
P19" L78" H29.53"

Finishes

burnished black / glossy lead,
black rose / glossy blue,
burnished black / smoked oak /
volakas marble.

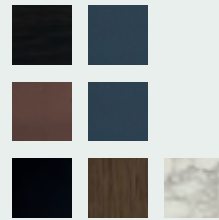

kendo pages 577



by Manzoni&Tapinassi

The Kendo Sideboard completes the Dining area, elevating the project with elements of highly-skilled cabinetwork. Base and details in laser-cut sheet metal which has been curved, polished and painted in various finishes. Storage units and tops with detailing in solid walnut or oak and panels in various different kinds of wood. Door with wing-type opening and handle with milled edges. The interior of the sideboard is made entirely in wood. Internal shelves are available in extra-light tempered glass with polished ground edges (8 mm thick).

Sideboard

- L198 P50 H80 cm
L77.95" W19.68" H31.49"

Frame finish

- smoked oak – brass



fortuna pages 224, 441, 552, 555, 584



by Claudio Bellini

The Fortuna sideboard has a weight-bearing frame and legs in solid wood available in a variety of woods, including European Oak and Walnut. Damping systems for drawers and tempered-glass top with a scratch-resistant acid-etched surface and extra-light back-etching for the milk-white finish, or float glass for the coffee-brown or Rope finish. Available also in new tobacco-brown ash wood with a top in the same wood instead of glass.

Sideboard

- L220 P50 H72 cm
L86.61" W19.69" H28.35"

Finishes

- **frame**
smoked oak, oak grey,
ash wood tobacco

- **top**
glazed white, glazed coffee
brown, ash wood tobacco



orfeo pages 313, 317, 333, 343, 347



by Manzoni&Tapinassi

Combinations and mixtures of precious materials and attention for detail are the factors that run throughout the whole collection. Structure in turned, polished and painted metal available in two colours with end decorations. Sideboard and Curio Cabinet in curved plywood with a matte lacquered finish in two different colours. Doors with full matte lacquered finish and handle detail in painted aluminium with a brass finish, or in a glossy rose-gold tone. Door with wing-type opening and hinge with damping closure. Shaped internal shelves with matte lacquered surface in the same colour as the exterior. Also available as a back-sofa console and triptych-style console in two different compositions.

Sideboard

- L117 P50 H140 cm
L46.06" W19.69" H55.12"

Finish

- **frame**
matte anthracite lacquered/
metal structure in burnished
black/brass

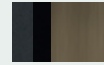

cala pages 627, 629, 630



by Claudio Bellini

Exquisite materials, fine craftsmanship and custom-made details. Each storage unit is a precious object in itself. The front of the drawers and the sides of each piece have been completely covered in leather with tonal stitched detailing for a refined effect.

The chest of drawers and bedside tables have sides in curved plywood completely covered in leather in various colours and in pre-set combination of a wooden top in smoked oak or walnut. Partial pull-out drawers equipped with a push/pull opening mechanism and soft closure. The inside of the drawers are partially in wood that matches the exterior. The bedside table has been completed with an extra shelf in tempered glass a with glossy effect in various pre-set combinations. The chest of drawers and bedside tables are fitted with height-adjustable feet. Real leather has been used for the coating (100% cow leather with linear grain and chrome tanning).

Chest of drawers

- L201 P54 H72 cm
L21.26" W79.13" H28.35"

Bedside table

- L57 P49 H43 cm
L19.29" W22.44" H16.93"

Finishes

- **frame**
dark brown
- **top**
walnut



phantom pages 472



by Mauro Lipparini

The visual purity of Phantom's silhouette brings together two opposites: the grandeur of wood and impalpable nature of glass. Artisanal manufacturing, meticulous attention to detail.

Set on two panes of ultra-clear almost invisible glass, the line of the sideboard is centred around the combination of different materials that make the design of this project highly distinctive.

Dimensions

- L200 P53 H73 cm
L78.74" P20.87" H28.74"
- L200 P53 H88 cm
L78.74" P20.87" H34.65"
- L90 P53 H130 cm
L35.43" P20.87" H51.18"

Finish

- **frame**
Walnut, walnut & wine, smoked oak
- **top**
Walnut, volakas marble, invisible
gray marble, light blue laquer

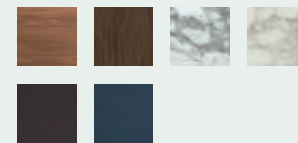

campus bedside table pages 192, 195, 196, 599, 600



by Mauro Lipparini

The night system includes two versions of bedside table, a version made of eucalyptus wood with inserts and solid wood craftsmanship, and a hexagonal version with container in glossy lacquer and sliding top, to allow total opening of the storage compartment. The interior of the compartment is in matt lacquer in the same color.

Bedside table

L70 P41 H45 cm
L28" W16" H18"

Exagonal bedside table

D47 - P42 - H52cm
D19" - W17" - H20"



campus dresser pages 601



by Mauro Lipparini
A refined identity and modern decoration. The sophisticated design of the dresser and drawer unit redefines the sleeping area. Contemporary and elegant, it enhances functionality at the same time. These two pieces are made of high-density fibreboard from eucalyptus wood for a natural beauty that stands the test of time.

Night dresser
L170 P55 H74 cm
L67 W22 H29"

Chest of drawers
L170 P55 H135 cm
L28 W22 H53"

Finishes
Night dresser and chest of drawers are provided with a base in laser cut steel sheet, polished and liquid painted in glossy black chrome. Solid wood details for edges and fronts. Top in glossy lacquer - high gloss. Drawers with matching interior in matt brown lacquer. The drawers are equipped with side opening with soft closing.

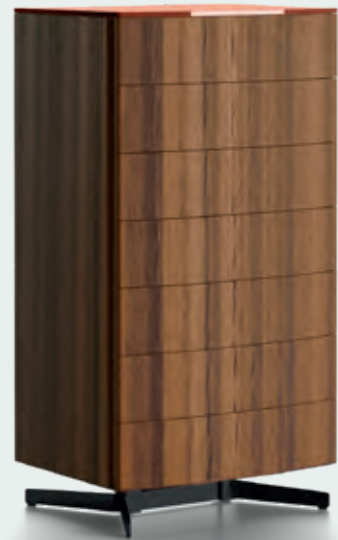

euclide pages 635, 637, 638



by Manzoni&Tapinassi
The Euclide collection boasts sublimely subtle detailing: metal lacquered drawer handles that match the structure, the sleek design of the feet that rise and melt into the rest of the frame and a fully lacquered interior. The drawers have a "soft closure" mechanism. Shelf in bronze-coloured glass.

Bedside table
- L60 P50 H40 cm
L23.62" W19.69" H15.75"

Chest of drawers
- L190 P55 H65 cm
L74.8" W21.65" H25.59"

Finishes
- **frame**
matte coffee-brown lacquered
- **feet**
matte coffee brown



fenice pages 651, 652



by Bernhardt & Vella
Structure in curved poplar plywood with outer parts featuring a matte lacquered or wood-plated finish. The drawer fronts have solid wood edges finished in various colours of glossy lacquer or wooden colours. The top of the chest of drawers is in finger-print-resistant glass and lacquered on the underside (4 mm thick). Drawers with a matte lacquered internal coating in the same colour as the exterior. Chest of drawers with push-pull opening mechanisms and a damping Blumotion closure. Non-slip and non-marking feet in ABS available for both the chest of drawers and the bedside tables.

Bedside table - left & right
- L60 P50 H53 cm
L23.62" W19.69" H20.87"

Chest of drawers
- L140 P50 H78 cm
L19.69" W55.12" H30.71"

Finishes
- **frame**
white chalk, mink, walnut, smoked oak

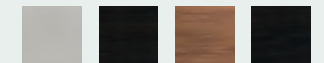

mondrian pages 654, 657, 658



by Claudio Bellini

Featuring a clean and minimalist design, this system consists of a chest of drawers and bedside tables with pristine silhouette. Structure in lacquered wood available in various colours as per the catalogue or in walnut wood. The base and side panel come in anthracite metal that picks up on the detailing and overall design of the door. The drawers with a soft-close mechanism have been fully lacquered on the inside and match the exterior. With a huge variety of sizes and finishes, this range is extremely versatile.

Finishes

- **frame**
matte white, matte mocha-brown, matte blue, matte light grey, walnut
- **feet**
anthracite metal/
coffee-brown metal

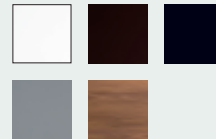

Bedside table - left & right

- L60 P50 H40 cm
L23.62" W19.69" H15.75"

Chest of drawers

- L160 P50 H70 cm
L62.99" W19.69" H27.56"



svevo pages 620, 622, 661



by Manzoni&Tapinassi

The living-area project boasts a mixture of different materials, such as wood, metal for the detailing and glass for enhancing furniture surfaces. Svevo has a novel coordinated look that taps into a nostalgic aesthetic. SVEVO will take centre stage in the bedroom area.

The Svevo range features solid-wood legs (available in smoked oak and walnut) that seem to rise up to embrace the frame and have been embellished with sublime metal detailing. Drawers in wood finished with a glass top which is slightly recessed to allow for the opening of the handleless doors on the bedside table and for the drawers. Tempered-glass top with a scratch-resistant acid-etched effect in a matte coffee-brown colour. Drawer with a soft-close mechanism.

Bedside table

- L78 P48 H50 cm
L18.9" x W30.71" H19.69"

Chest of drawers

- L200 P55 H77 cm
L21.65" W78.74" H30.31"

Finishes

- **frame**
smoked oak/brass metal



munari pages 642, 645



by Manzoni&Tapinassi

A project with a strong personality also underscored by the choice and combination of materials. Solid-wood elements with a choice of a wooden or marble top. The piece has been elegantly finished and lacquered inside with a soft-closure system.

Sideboard

- L220 P53 H75 cm
L86.61" W20.87" H29.53"

Bedside table left and right

- L65 P45 H41 cm
L25.59" W17.72" H16.14"

Finishes

- **frame**
smoked oak
- **top**
calacatta gold , smoked oak

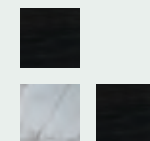

venere pages 666, 671



by Bernhardt & Vella

Weight-bearing structure in curved laser-cut sheet metal (8 mm thick), with a polished and painted finish; available in different colours. The chest of drawers and the front are in curved poplar plywood while the exterior is lacquered or veneered in various types of wood. The interior of the drawers has lacquered to match the external finish. Jewellery drawer with a wooden bottom and decorative latticework in painted wood. Fully extractable drawers with Blum guides and a push-pull opening mechanism.

Bedside table

- D50 H56 cm
D19.69" H22.05"

Chest of drawers

- L150 P55 H77 cm
L59.06" W21.65" H 30.31"

Finishes

- frame

walnut, smoked oak, glossy white chalk, glossy jade

- feet

brass, glossy black chrome

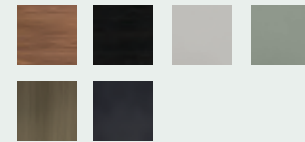

affresco pages 175, 180, 183, 298, 379, 472



by Natuzzi Design Center

The Affresco rug has been salt washed and neutralised from its original state and then over-dyed to produce its original and unique colour scheme and patterning. It calls to mind nineteenth-century design traditions while the washing treatment gives it a bold contemporary feel.

Material
100% wool

Technique
hand knotted

Dimensions

- L280 P380 cm
L110.24" W149.61"

Finishes Colour
blue, grey, brown, natural

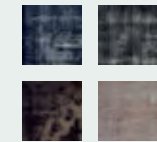

papel page 21



by Ar-o studio

Papel is our collection of loom-woven paper yarn carpets. Paper has a surprisingly different appeal than other materials: it is natural and sustainable, easy to clean and dirt resistant thanks to a strong protective film on the surface. Moreover, it is made from FSC and PEFC certified paper yarns, to fully respect the forests of origin and those who produce them.

Materials

100% paper

Technique

Hand made

Dimensions

- L200 P300 cm
- L78.74" W118.11"
- L300 P400 cm
- L118.11" W157.48"
- L400 P500 cm
- L154.48" W196.85"

Finishes colour

Black, Natural and White
Rope and White

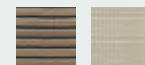

calcada pages 369, 374

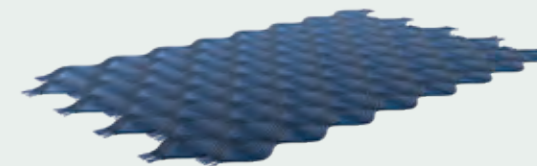

by Sopa Studio

Featuring an iconic combination of bouclé and high-pile hand tufting, Calçada has woven fringed ends which taps into the cosy aesthetic of a traditional wool rug.

Materials
100% Wool

Technique
Hand-tufted

Dimensions

- L200 P300 cm
- L78.74" W118.11"
- L300 P400 cm
- L118.11" W157.48"

Finishes colour
blue



globes pages 104, 108, 342

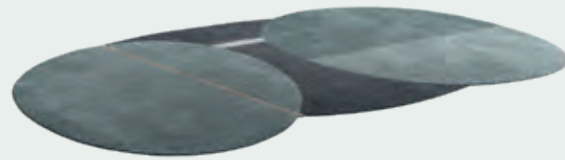

by Carlotta Fortuna
Overlapping chiaroscuro shadows and sand-hued details raise the unmistakable silhouette of the Globes rug to exquisite heights. The tactile beauty of the hand-tufting is a nod to the texture of classic rugs.

Materials
70% Wool, 30% Viscose

Technique
Hand-tufted

Dimensions
- L200 P300 cm
L78.74" W118.11"
- L300 P400 cm
L118.11" W157.48"

Finishes colour
blue



jade pages 441

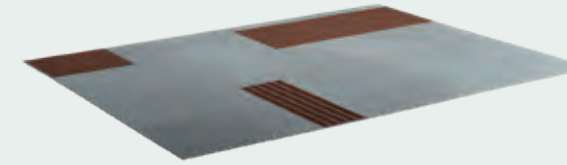

by Studio Tomorrow
The deft weaving and tactile textures create an up-tempo feel with a classic colour scheme or an aesthetic with a strong personality.

Materials
90% New Zealand wool, 10% Cotton

Technique
Hand woven and tufted

Dimensions
- L200 P300 cm
L78.74" W118.11"
- L300 P400 cm
L118.11" W157.48"

Finishes colour
light grey and champagne



gorgonia pages 70, 72



by Elena Salmistraro
Gorgonia showcases the excellence of Mediterranean Italy in the patterns, choice of materials and production techniques. A rug with geometric design made by hand according to the crochet technique sewn on the backing of the carpet. The yarn for the crochet is made from recycled plastic fibers (100% PET). The versatility of Gorgonia is expressed either indoors, where it can also be placed under a dining table or in a busy environment, and outdoors, on a balcony or terrace, thanks to its backing made of plastic material that does not deteriorate.

Technique
Crochet

Materials
recycled PET (matt)

Dimensions
- L200 P300 cm
L78.74" W118.11"

Colors
grays, mint green and gold

luce pages 55, 157, 159, 303



by Silvia Fanticelli
With an attractive series of lines, the Luce rug features the silken texture and lustre of tencel® which gives way to the matte robustness of wool with a soft rounded figure on one side. The Luce rug has been handmade in India with a hand tufting technique and catches the eye with its subtly sculpted geometric patterning that brings to mind beams of light and a spectrum of colours.

Materials
65% Wool, 35% Tencel®

Technique
Hand-tufted

Dimensions
- L200 P300 cm
L78.74" W118.11"
- L300 P400 cm
L118.11" W157.48"

Finishes colour
terracotta



magna grecia pages 64, 135, 138



by Marcel Wanders studio
The pattern is repeated almost endlessly on the tufted surface, creating a mystical optical effect.

Materials
100% polyester

Technique
Digital printing on a polyamide base

Dimensions
- L200 P300 cm
L78.74" W118.11"
- L300 P400 cm
L118.11" W157.48"

Finishes colour
blue and taupe



seti pages 119, 176, 192, 271, 290, 313, 316

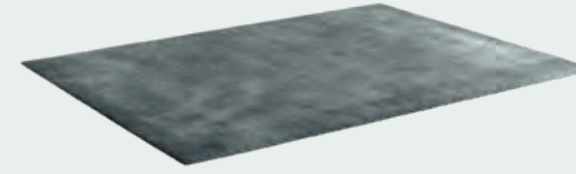

by Natuzzi Design Center
This refined carpet is made from 100% bamboo silk which ensures greater strength, flexibility and ease of handling. Bamboo silk is an eco-sustainable fabric that boasts all the main advantages of silk.

materials
100% bamboo silk

technique
Hand woven

Dimensions
- L200 P300 cm
L78.74" W118.11"
- L300 P400 cm
L118.11" W157.48"

Finishes colour
silver, mink, sea water



new decò pages 164, 168, 233

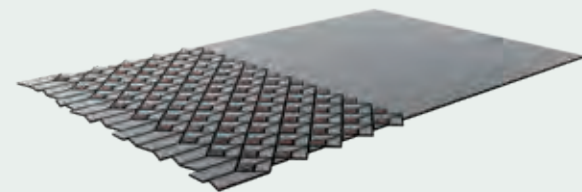

by Myo Creative Lab
Retro references for the refined weaving of the New Decò hand-knotted carpet. The subtle light grey wool surface is elegantly punctuated by a regular knit pattern that highlights glossy silken patches in a terracotta hue.

Materials
85% Wool, 15% Tencel®

Technique
Hand-knotted 60M knots

Dimensions
- L200 P300 cm
L78.74" W118.11"
- L300 P400 cm
L118.11" W157.48"

Finishes colour
grey



silence pages 425, 429, 457

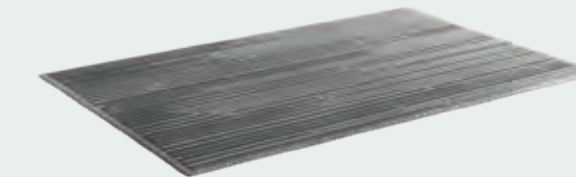

by Zaven
The sublimely sculpted patterning on this tufted rug bespeaks the fine manual skills and outstanding techniques used to create this unique piece of décor.

Materials
100% Wool

Technique
Hand-tufted

Dimensions
- L200 P300 cm
L78.74" W118.11"
- L300 P400 cm
L118.11" W157.48"

Finishes colour
grey



sophia b

pages 81, 90, 99, 110, 128, 140, 146, 187, 196, 203, 212, 219, 224, 229, 239, 276, 343, 352, 390, 403, 407, 413, 488, 552, 568, 610, 620, 627, 648, 654, 666



by Natuzzi Design Center
The collection of solid Tencel® Sophia B rugs achieves its lustre due to the slightly lower (a few millimetres) height of the soft hand-woven pile, giving it a fresh and subtly nuanced appearance. A huge choice of solid colours will allow you to find just the right one to elevate your bedroom or living room.

Materials
100% Tencel®

Technique
Hand-woven

Dimensions
- L200 P300 cm
L78.74" W118.11"
- L300 P400 cm
L118.11" W157.48"

Finishes colour
deep lichen green, granite grey, major brown, coconut shell, tap shoe, walnut, maroon, cherry mahogany, moonlit ocean, antarctica, mushroom, dijon, rainy day, pellican.

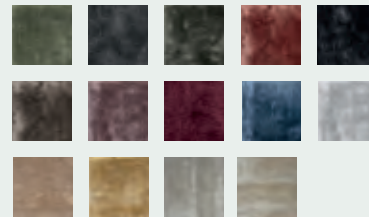

vortex

pages 243, 249, 249, 252, 558, 643, 661

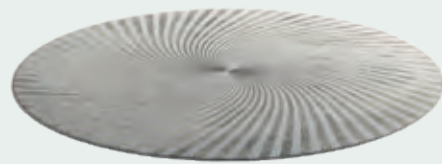

by Nika Zupanc
With two different piles for each of the shades (a higher pile for the gold and platinum and a shorter pile for the ivory base), Vortex adds to the line-up of round rugs for the living room or bedroom in the Natuzzi Italia catalogue.

Materials
43% viscose, 42% acrylic, 12% cotton, 3% latex

Technique
Machine tufted

Dimensions
- D250 cm
D98.43"

Finishes colour
gold, platinum

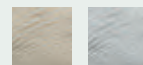

circle

pages 441, 539, 584, 643, 645

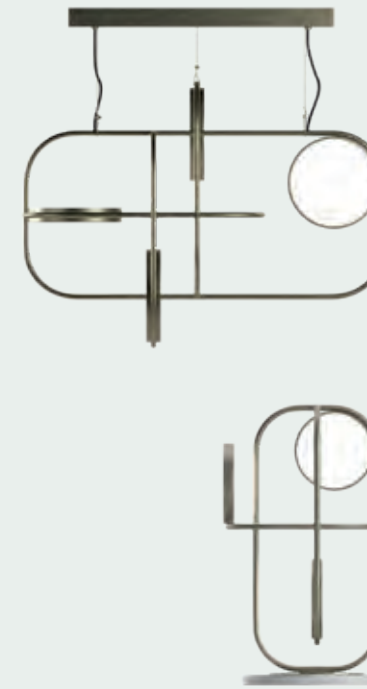

by Massimiliano Raggi
Collection of lamps in polished, painted metal with metal rod of a diameter of 12 mm. Lighting devices in opaline glass with a led strip inside. Light 2700 kelvin degrees.

Dimensions
table lamp
- L27 P31 H52 cm
L10.63" W12.2" H20.47"

pendant
- L50 P55 H55 cm
L19.69" W21.65" H21.65"

Finishes
- frame
brass, black gloss chrome
- lampshade
white
- base
volakas marble

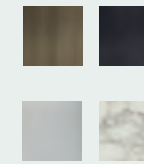

colosseo

pages 80, 81, 172, 176, 183, 187, 192, 271, 284, 298, 307, 369, 407, 408, 472, 568, 643

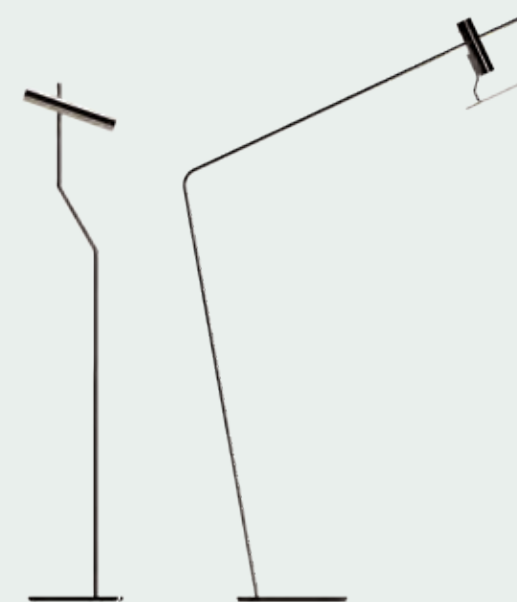

by Mauro Lipparini
Colosseo, a collection of lamps in tubular metal with a 14 mm diameter. Adjustable-angle telescopic-lighting devices in polished, painted tubular metal. Integrated 3,000 kelvin degrees Citizen led light. Remote transformer. Coaxial cable.

Versions
floor lamp
- L13 P26 H141 cm
L5.12" W10.23" H55.51"

table lamp
- L22 P27 H49 cm
L8.66" W10.63" H19.29"

pendant lamp
- L5 P26 H63 cm
L1.97" W10.24" H24.8"

arch
- L45 P140 H230 cm
L17.71" W55.11" H90.55"

Finishes
- frame
champagne, black chrome,
- lampshade
white



dami

pages 104, 110, 212, 215,
215, 229, 239, 552, 571



by Marcel Wanders studio
The diffuser comes in mouth-blown glass with a metallic shade which makes it extremely luminous. Available in the ceiling version and a floor version with a metal base and countertop. Electric cable in black material. E27 replaceable LED bulb socket not supplied.

Versions
floor lamp
- L50 P50 H180 cm
L19.69" W19.69" H70.87"

table lamp
- L35 P35 H50 cm
L13.78" W13.78" H19.69"

pendant
- L35 P35 H48 cm
L13.78" W13.78" H18.9"

Finishes
- **frame**
black
- **lampshade**
copper/transmirror

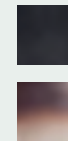

ding dong

pages 264, 266, 419



by Marcel Wanders studio
A dainty bluebell completely covered in fine Natuzzi leather. The inside of the light comes in painted aluminium and the outside in white leather.

Version
pendant lamp
- L22 P22 H75 cm
L8.66" W8.66" H29.53"
- L35 P35 H84 cm
L13.78" W13.78" H33.07"
- L45 P45 H94 cm
L17.72" W17.72" H37.01"

table lamp
- L22 P22 H48 cm
L8.66" W8.66" H18.9"

floor lamp
- L45 P45 H179 cm
L17.72" W17.72" H70.47"

Finishes
- **frame**
white
- **lampshade**
white



elsa

pages 390, 496

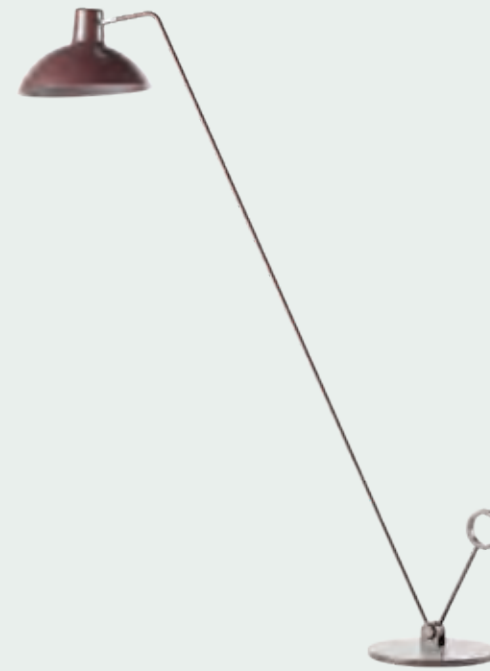

by Natuzzi Design Center
Designed as a reading lamp, both the floor and lampshade can be tilted to suit requirements. The table version is perfect for a writing desk.

Versions
floor lamp
- L127,5 P30 H158 cm
L50.2" W11.8" H62.2"

Finishes
matte blue, matte green,
matte marsala

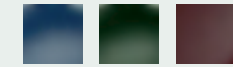

galileo

pages 403, 488, 492, 492, 503, 627, 635, 648



by Michele Menescardi
Base made of Calacatta Crema marble or black lacquered beech wood with a distressed effect. Lampshades in printed, painted aluminium available in 4 different colour variants. Light bulb holder for single incandescent E27 light bulb. Cable with black fabric sheath.

Versions
table lamps
- L18 P14 H35 cm
L7.09" W5.51" H13.78"
- L23 P17 H45 cm
L9.06" W6.69" H17.72"

Finishes
- **base**
Volakas marble, black wood
- **lampshade**
glossy white, glossy grey,
glossy blue, Havana, clay

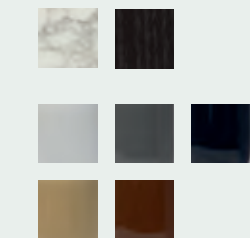

halo pages 316, 320, 333



by Massimiliano Raggi
Collection of lamps in polished, painted metal: internal finish in a champagne hue, exterior in burnished nickel and strip led lighting inserted into a corrugated pyrex tube. Led illumination. Metallic structure.

Versions
table lamp
- L18 P23 H58 cm
L7.09" W9.06" H22.83"

floor lamp
- L26 P33 H178 cm
L10.24" W12.99" H70.08"

pendant lamp
- L16 P19 H50 cm
L6.3" W7.48" H19.69"
- L32 P23 H60 cm
L12.6" W9.06" H23.62"

Finishes
- **frame**
burnished nickel/champagne
- **lampshade**
white



kendo pages 119, 122, 180, 343, 578



by Maurizio Manzoni
Collection of lamps coordinated with the Kendo furnishing range. The warmth of wood and the brightness of metal create a unique and original contrasting effect.

Versions
table lamp
- L44 P44 H44 cm
L17.32" W17.32" H17.32"

floor lamp
- L51 P51 H170 cm
L20.08" W20.08" H66.93"

Finishes:
- **frame**
smoked oak, brass and walnut, pewter
- **lampshade**
white

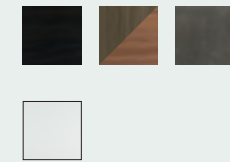

joy pages 243, 256, 261, 261, 252, 558, 562, 562



by Nika Zupanc
The Joy lamp has a light-gold finish, ceramic details and an iridescent glass sphere. The metal has undergone a polishing and powder coating process, a protective and decorative coating that guarantees superior scratch-resistance, exceptional durability and ease of cleaning.

Versions
arch lamp
- L140 P48 H185 cm
L55.12" W18.90" H72.83"

floor lamp
- D48 H185 cm
D18.90" H72.83"

table lamp
- D30 H55 cm
D11.81" H21.65"

pendant lamp
- D30 x H50 cm
D11.81" H19.69"

Finishes
iridescent transparent glass,
matte white ceramic,
light-gold metal

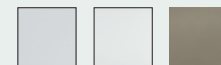

vico pages 196, 224, 359, 466, 620, 654, 661, 666



by Victor Vasilev
The aim of this project was to achieve a perfect balance to make it look as if the top is suspended over the base. The structure and shade of the Vico lamp come in painted metal; the shade features a round Plex top for a softer light.

Versions
table lamp
- L20 H 36 cm
L7.87" H14.17"
- L28 H50 cm
L11.02" H19.69"

Finishes:
- **frame**
white
- **lampshade**
white



anemonia page 74



by Elena Salmistraro

A mirror which merges geometric elements taken from the shapes of tuff quarries and the organic elements of the sea. Functional and of great scenic impact, it contains three possible configurations in a single element:

- Free standing mirror, in the living room or bedroom
- Wall mirror in vertical position, for the entrance or the bedroom
- Wall mirror in a horizontal position, for the living room, lounge or bedroom

Structure & Materials

metal structure, frame enhanced by 3 metallic tubes

Dimensions

- L102 H190 cm
L40.15" H74.80"

Colors

black, matt gold, shade of mint green



chocolat pages 187, 591, 593

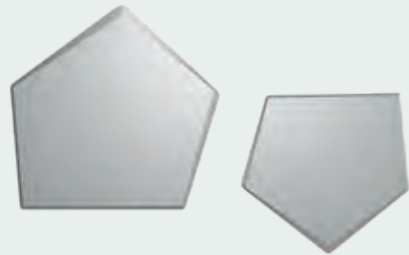

by Natuzzi Design Center

5 mm thick silver-tone mirrored glass with a chamfered and bevelled effect set on a matte black lacquered support. Available in different versions.

Dimensions

- L81 H75 cm
L31.89" H29.53"
- L100 H97 cm
L39.37" H38.19"

Finishes

mirror



clouds pages 672



by Natuzzi Design Center

Clouds is a curved-shaped wall mirror available in various finishes.

Dimensions

- L130 H53 cm
L51.18" H20.87"

Finishes

smoked mirror, mirror



kendo pages 290, 316, 664



by Manzoni&Tapinassi

Kendo mirror with a solid walnut or oak frame and painted metal inserts. Mirror in bronzed glass.

Dimensions

- D120 cm
D47.24"

Finishes

walnut pewter/glass bronze, smoked oak/brass/glass bronze

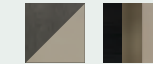

luminarie pages 210



by Marcel Wanders studio

Luminarie has an etched design on the back of the smoke-coloured mirror surface. Luminarie is available in two wall versions (square and arched).

The glass has been etched on the back so that the surface can be easily cleaned.

Wall attachment system available.

Dimensions

- L88 H208 cm
L34.65" H81.89"
- L88 H88 cm
L34.65" H34.65"

Finishes

smoked mirror



mermaid pages 256, 261, 558



by Nika Zupanc

Etched patterning that is reminiscent of the scales on a mermaid's tail embellishes the thick glass with a bronzed finish.

Dimensions

- L52.5 H100 cm
L20.67" H39.37"

Finishes

bronze mirror



orfeo pages 180, 336



by Manzoni&Tapinassi
Mirror with bronzed glass and a mirror effect as well as a hand-aged surface with milled and polished visible edges. The mirror is supported by laser-cut sheet metal with an in-built hook.

Dimensions
- D78 cm
- 30.71"
- D103 cm
- 50.55"

Finishes
burnished black/brass/bronze



sailors pages 256, 261



by Nika Zupanc
Oval shapes custom cut from mirrored bronze. The diagonal etched patterning on Sailors gives it a nautical feel.

Dimensions
- 52.5 cm h 100 cm
- 20.67" h 39.37"

Finishes
bronze mirror



tailor pages 88, 627, 666, 675



by Claudio Bellini
Free-standing mirror that can be tilted to suit requirements. Metal structure with brass or pewter finish. Rotation mechanism with stopping system. The rear features a full matte finish. Base in curved, laser-cut sheet metal.

Dimensions
- L76 P31 H180 cm
- L29.92" W12.2" H70.87"

Finishes
pewter



dysidea pages 37, 70, 85, 99, 101

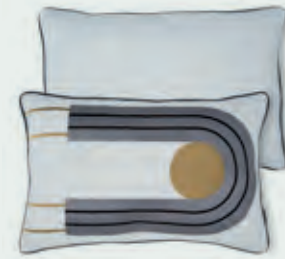

by Elena Salmistraro
The ultimate accessory which highlights and lifts the feel of the room. In the Posidonia collection for Natuzzi Italia, Elena Salmistraro dedicates special attention to the design of the Dysidea set of cushions. The key feature of the project is the graphic design that adorns the front. Inspired by the relationship between nature and the Apulian seascape and contemporary lifestyle, the decorative motifs combine shapes inspired by tuff quarries, with the organic, undulating and abstract elements, of the sea that surrounds Apulia.

Enriched with details and material elaboration, the cushions in two dimensions fully express the graphic richness of the world of Posidonia. The collection comes in 3 color variations in the moods 2021/2022 by Natuzzi Italia.

Structure & Materials
fabric

Dimensions
- L50 P50 cm
- L20.47" W20.47"
- L32 P50 cm
- L13.39" W20.47"

kashmir



by Natuzzi Design Center
Collection of elegant blankets with fringing made of pure lofty cashmere. The natural colours give the collection a subtle allure.

Dimensions
- L130 P180 cm
- L51.18" W70.87"

Finishes
beige, grey, brown, taupe



trulli

page 303, 403, 627



by Marcel Wanders studio
Jacquard throw made in pure virgin wool in natural colour.

Dimensions
- L140 P180 cm
L55.12" W70.87"

Finishes
beige



ciambotte

pages 70

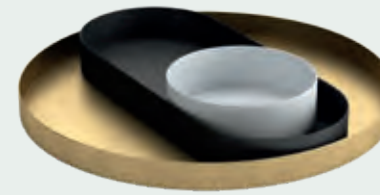

by Elena Salmistraro
Made of lightweight and metal, the three concentric trays form a set with a strong aesthetic impact in their minimalist design. Elena Salmistraro has focused on the visual impact of the geometric shapes, the construction and deconstruction of classic styles adapted to the contemporary environment and demands of modern life. The lines of the elements are a common thread running through all the decorative styles that the designer has used to adorn her new collection for Natuzzi Italia, the hallmark of the Mediterranean mood and the brand's expertise.
To be placed separately as a valet tray or to be stacked for a perfect Vitruvian result.

Materials
lacquered inox

Dimensions
- D40 H4 cm
D15.74" H1.57"
- L39 P16 H4 cm
D15.35" W6.29 H1.57"
- D15 H5 cm
D5.90" H1.57"

Colors
gold, black and silver



dandy

pages 119, 212, 407



by Marcel Wanders studio
Dandy candle holders are real sculptural pieces made of Trani stone, one of the varieties of marble and stone from Apulia that is cut by a waterjet machine and hand finished for precision. Dandy candle holders are available in 5 different shapes.

Dimensions candle holder
- D12.5 H25 cm
D4.92" H9.84"
- D17.6 H19 cm
D6.93" H7.48"
- D19 H13.6 cm
D7.48" H5.35"

Finish
trani stone



pumo ceramic flower bud

pages 64, 99, 110, 114, 128, 146, 164, 196, 199, 199, 219, 233, 239, 243, 264, 271, 290, 313, 316, 325, 333, 343, 352, 369, 397, 425, 441, 462, 479, 488, 558, 568, 584, 643



by Natuzzi Design Center

A Pumo is a traditional craft item from the Apulia region. It is handmade with lathe machines and glazed inside ceramic Apulian kilns. The size and colour of these craft items may change and any variations must be understood to be part of the artisanal process and a mark of its genuine handmade Italian character.

Cleaning Instructions

please only clean with damp cloth. Detergents must not be used

Dimensions

- D8 H10 cm
D3.15" H3.94"
- D9 H15 cm
H3.54" H5.91"
- D11 H15 cm
D4.33" H5.91"
- D13 H20 cm
D5.12" H7.87"
- D20 H30 cm
D7.87" H11.81"

Finish

blue, wine, bronze, platinum, gold

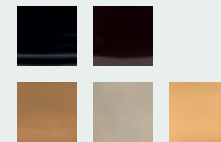

pumo flower

pages 199



by Natuzzi Design Center

The handmade Pumi in enamelled terracotta are a rekindling of ancient craftsmanship from the Salento area.

Dimensions

- D9 H15 cm
D3.54" H5.91"

Finishes

lilac, lime, rose

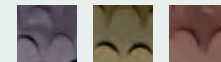

pumo glass



by Natuzzi Design Center

Made from hand-blown and hand-cast glass, these Pumi come from Eastern Europe. Available in four shapes and many transparent colours.

Dimensions

- D10 H15 cm
D3.94" H5.91"
- D17 H25 cm
D6.69" H9.84"
- D23 H25 cm
D9.06" H9.84"
- D24 H35 cm
D9.45" H13.78"

Finishes

blue, transparent, whiskey, lime green, violet

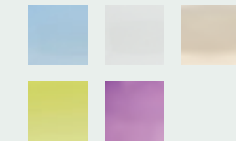

silo

pages 135, 303, 369, 462



by Marcel Wanders studio

The Silo vases from the Agronomist collection by Marcel Wanders feature the warm colours of our fertile Apulian land. Hand-made terracotta urns made by master ceramists from the Salento area. Glazed terracotta inside the urns and on the base; rope handles.

Dimensions

- D30 P30 H26 cm
D11.81" W11.81" H10.24"
- D35 P35 ch55 cm
D13.78" P13.78" H21.65"

Finish

terracotta



urchin pages 85, 149, 203, 276, 333, 472, 548



by Marcel Wanders studio
A collection of vases in Italian hand-crafted ceramic. The special three-dimensional patterning on the outside of the vase emphasises is reminiscent of a sea urchin. Available in matte white ceramic.

Dimensions
- D16 H8 cm
D6.3" H3.15"
- D20 H24 cm
D7.87" H9.45"
- D55 H15 cm
D21.65" H5.91"

Finish
white ceramic



voyage magazine holder pages 252, 254, 256

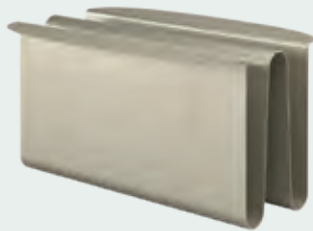

by Nika Zupanc
Made of curved laser-cut sheet metal, this magazine rack is polished with interpon powder and coated with a matte, gold-coloured smooth finish. Its exquisite gold-tone metallic finish gives it a jewel-like appeal. Positioned next to the seat or integrated into the pouf, it offers new furnishing solutions. The special paint creates a protective and decorative surface that guarantees high-scratch resistance, exceptional durability and easy cleaning. It is a single element that can either be placed on the ground next to the seat or integrated into the Wave pouf.

Magazine holder
- L67 P53 H41 cm
L26.38" W20.87" H16.14"

Finish
light gold



trullini pages 37, 60, 90, 264, 369, 446, 627



by Natuzzi Design Center
Candles or air scents with natural oil extracts, the Trullini cover five olfactory areas, each with its own distinctive colour and key note. Even after the fragrance finishes, these unique artisanal products become functional containers for small and precious objects. The clay is extracted from a quarry used since Etruscan times, then hand-turned and glazed. The textured clay base is embellished with drops of kiln-baked aventurine.

Dimensions
- D15.5 H20 cm
D6.1" H7.87"
- D15.5 H20.5 cm
D6.1" H8.07"
- D15.5 H21 cm
D6.1" H8.27"
- D15.5 H22 cm
D6.1" H8.66"

Finishes
- blue
- grey
- brown
- green
- light blue
- gold
- neutral
- black
- bordeaux

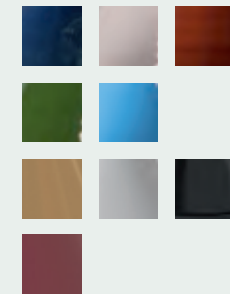

Photographers

Flavio&Frank
Massimo Gardone

3D Art

Suprema Unlimited Reality

Graphic design

Studio Sonnoli

Copywriting

Elio Buccino

Printing

Grafiche Antiga Spa

Special thanks to

Tony Chambers

copyright © natuzzi spa,
2020-2023

all rights reserved

All illustrations and descriptions of products contained in this catalogue are for indicative purposes only. We have tried our best to reproduce colours and finishings as faithfully as possible. However, we cannot guarantee that they correspond completely with those of the actual product.

The colours shown are limited and may vary according to print settings. Natuzzi S.p.A. reserves the right to amend and/or change aesthetics and/or functions and/or structures of products without any prior notice and as soon as any of the aforementioned changes are deemed necessary for commercial or manufacturing purposes.

Some products shown in this catalogue may not be available in your Country. Contact your nearest store for more information.

Natuzzi S.p.A. declines all and any liability for any printing errors or omissions.

The first version of the Natuzzi Italia Harmony Index was printed in December 2020.

Natuzzi S.p.A. All rights reserved.
Any unauthorised reproduction (including partial) copying, distribution, modification or use of contents (in any way whatsoever) is strictly forbidden.

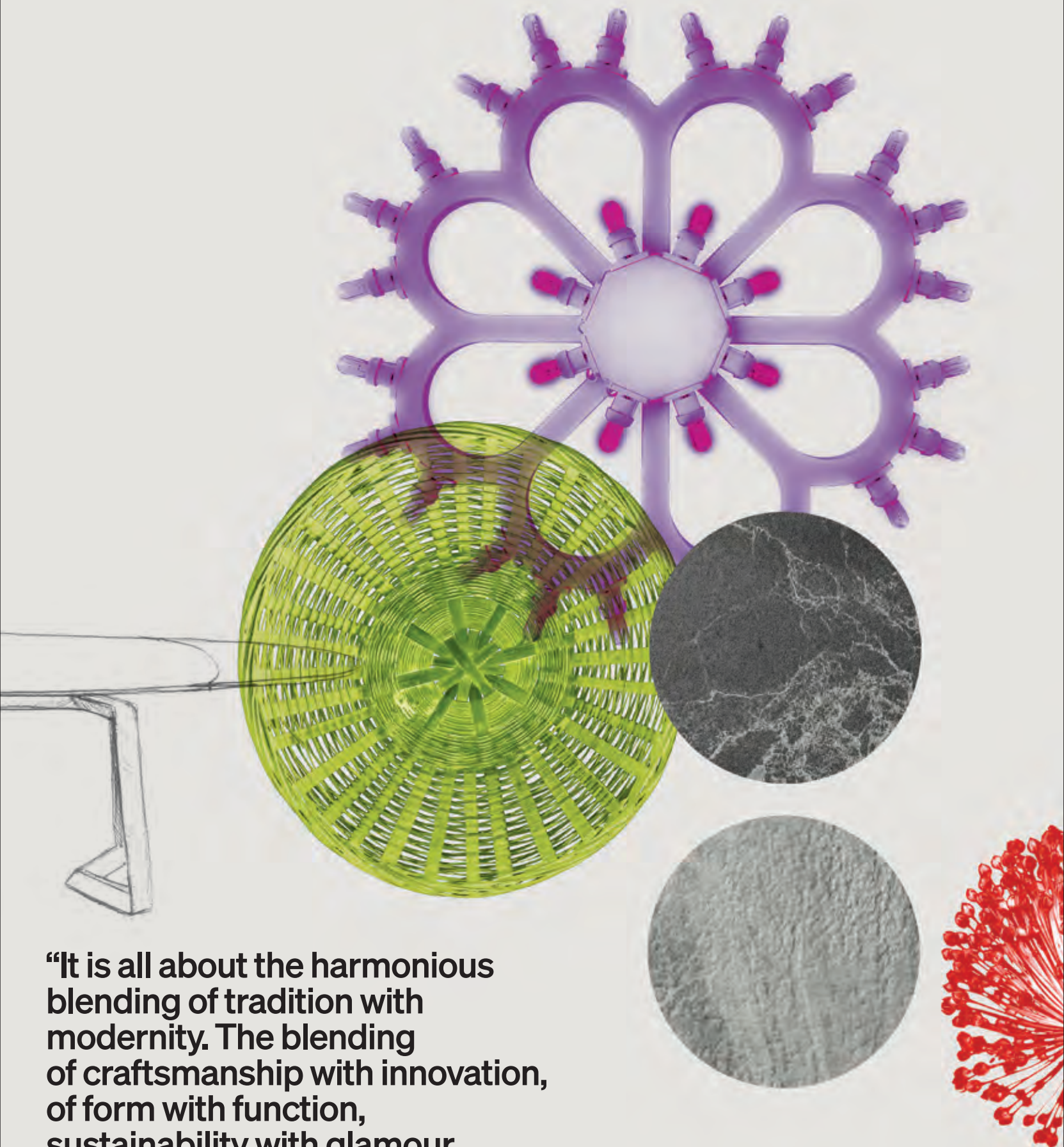

“It is all about the harmonious blending of tradition with modernity. The blending of craftsmanship with innovation, of form with function, sustainability with glamour, and comfort with style.”